

Támszerkezetek

I.

DR. SZEPESHÁZI RÓBERT

SZÉCHENYI ISTVÁN EGYETEM, GYŐR

(Rövidített szemléltető kivonat)

Áttekintés

Támszerkezetek funkciója

- Ideiglenes tereplépcsők oldalhatárolása
 - árkok
 - munkagödrök
- Felszín alatti építmények oldalfala
 - pincék, mélygarázsok
 - aluljárók, metrók
- Földművek, lejtők stabilizálása
 - hídfők, partfalak
 - bevágások, töltések
 - természetes lejtők

Támszerkezetek

- Támfalak
 - súlytámfalak
 - szögtámfalak
 - máglyafalak, gabionfalak
 - vasalt földtámfal, szegezett fal
- Befogott (támaszkodó) falak
 - résfalak
 - cölöpfalak
 - szádfalak
 - berlini dúcolat
- Horgonyzott (megtámasztott) szerkezetek
 - dúcolatok
 - elemes falak
 - bordák
 - gerendák

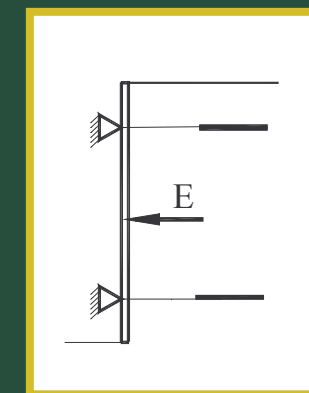
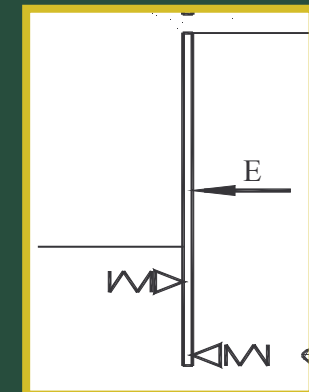
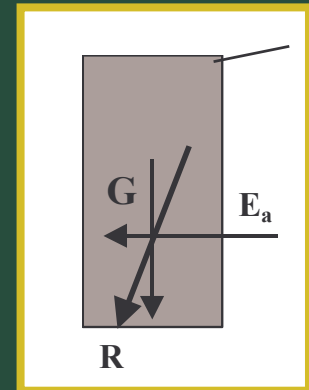

Támfalak

Támfalak

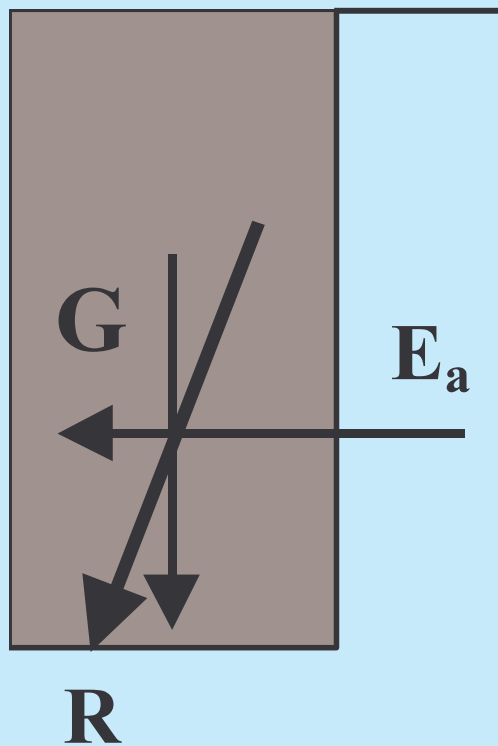

- súlytámfal
- szögtámfal
- máglyafal
- gabionfal
- erősített földtámfal
- szegezett fal

Súlytámfalak

Beton súlytámfalak

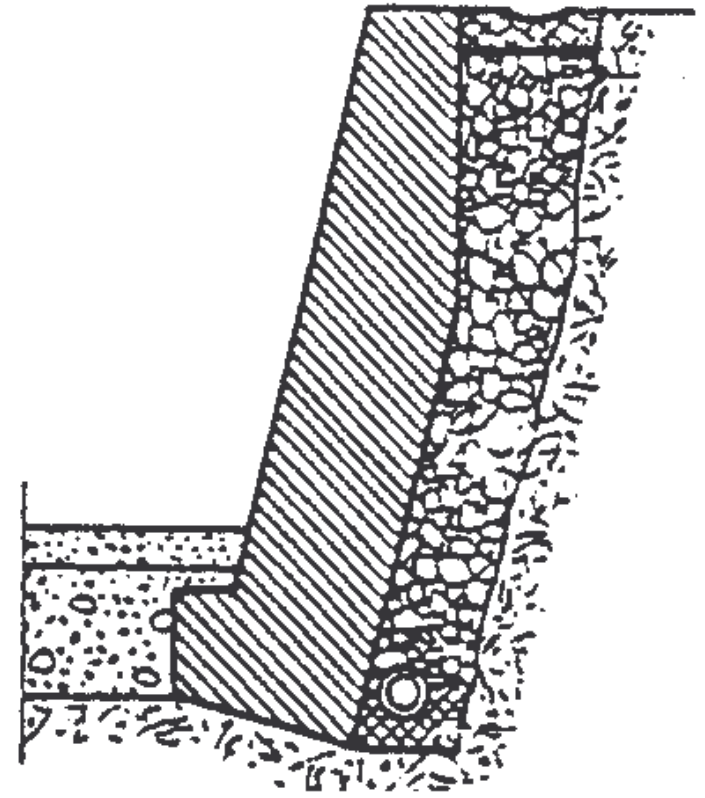
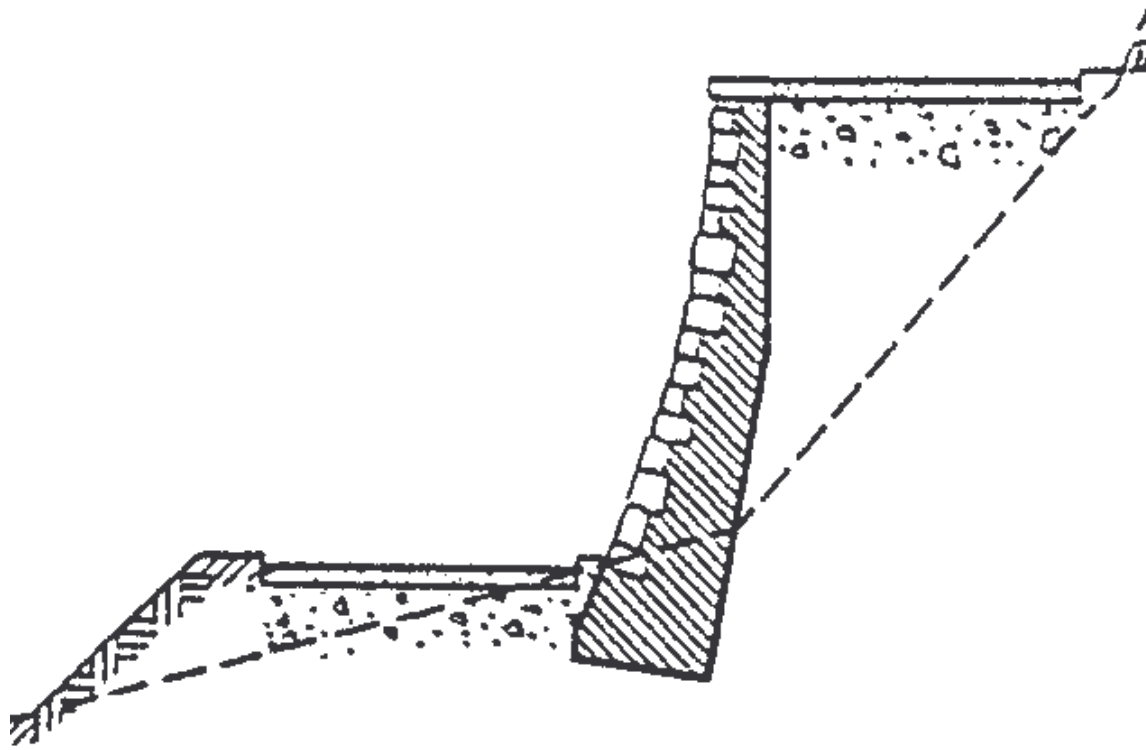





2004/09/20





2005/04/01 20:49

Erősített földtámfalak

Vasalt
föld
támfalak
szerkezete

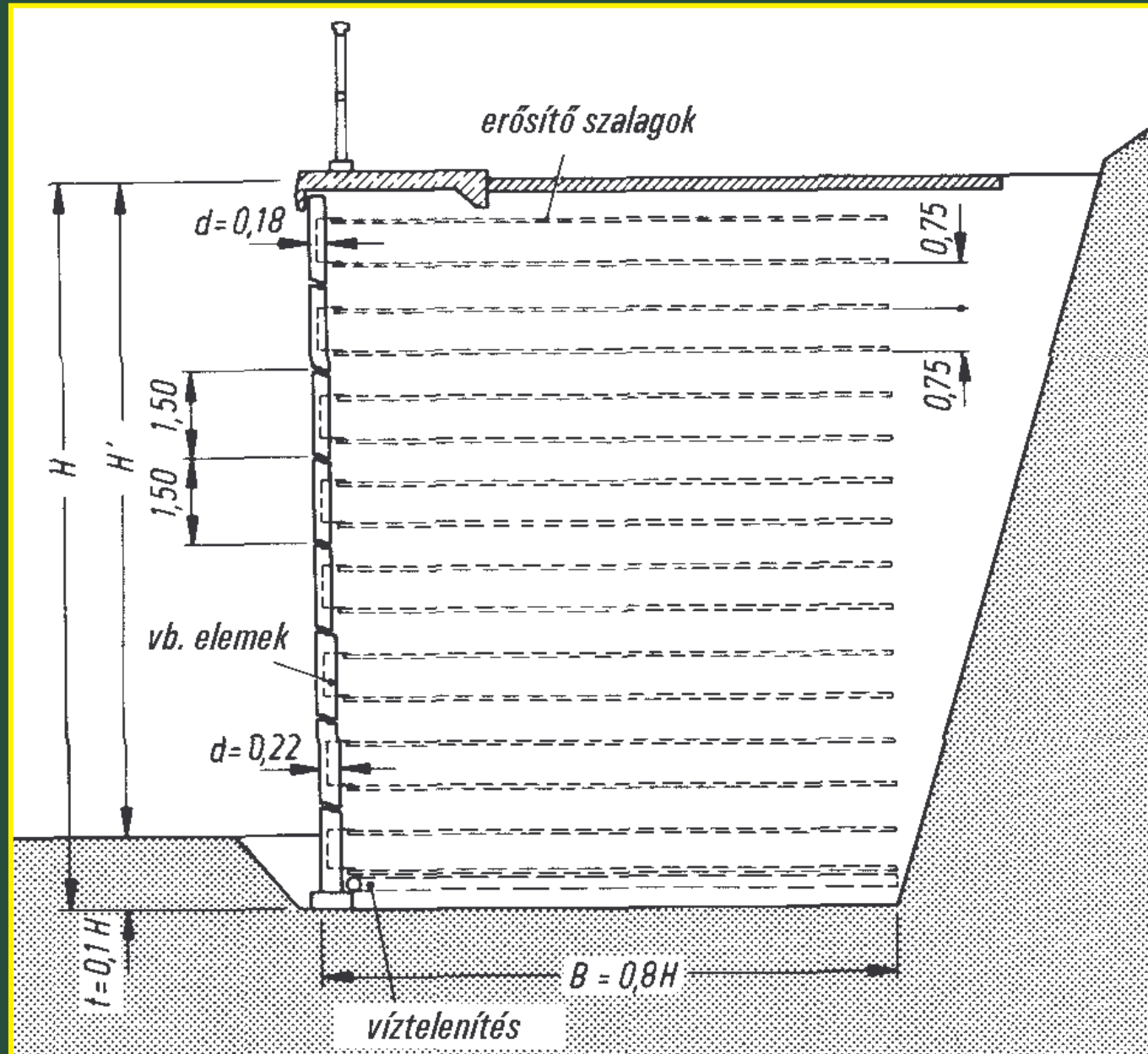

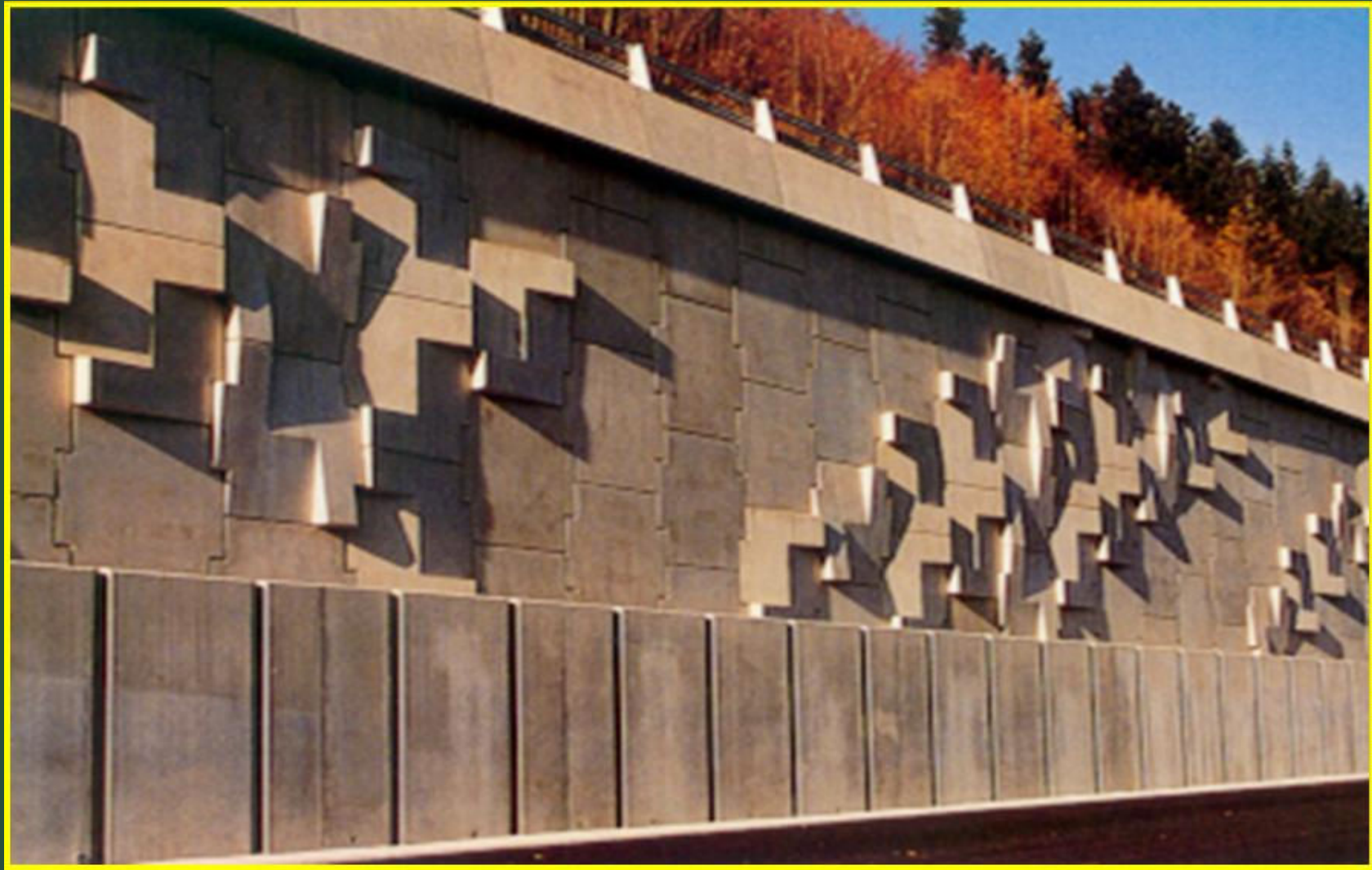



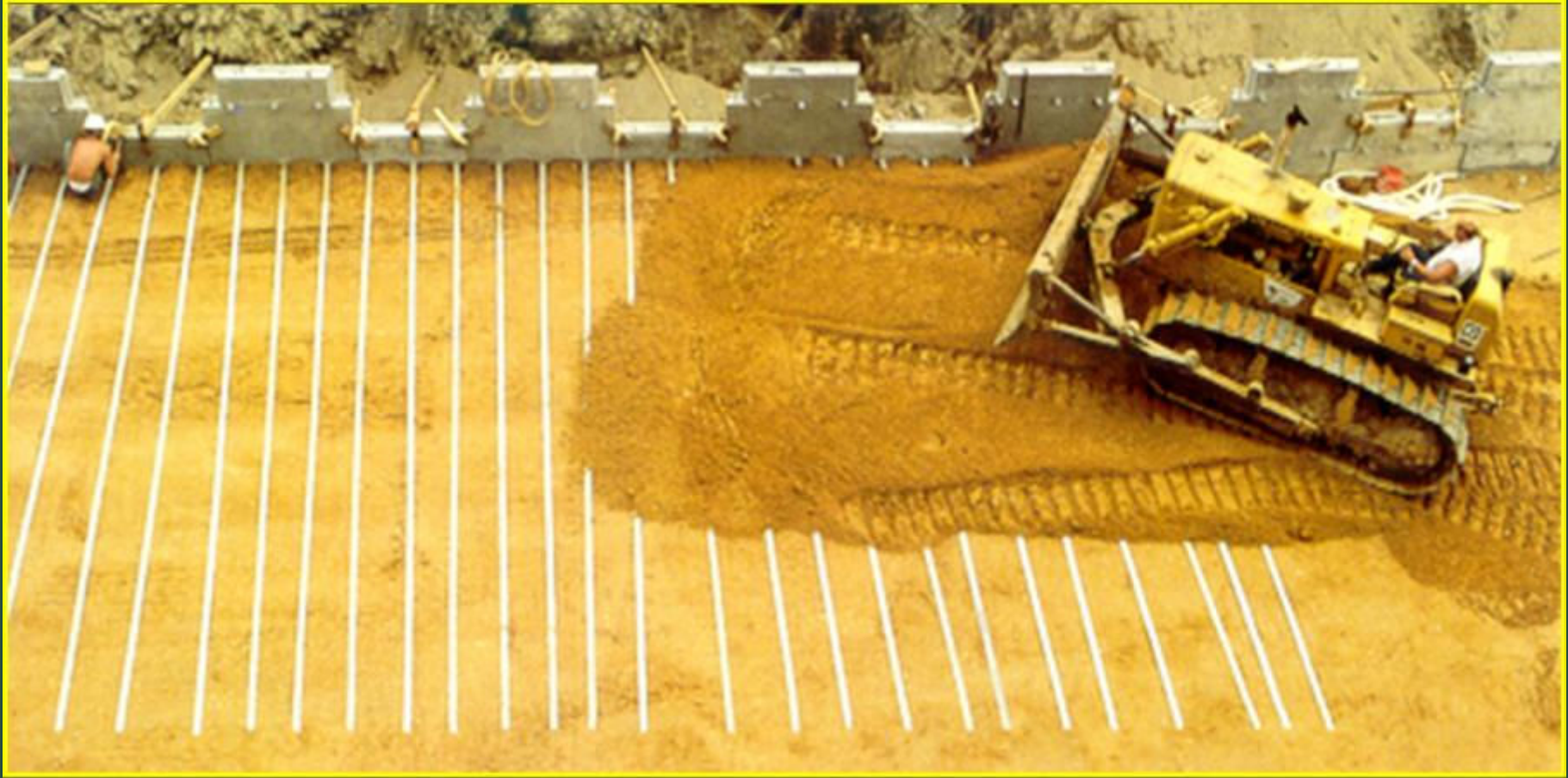



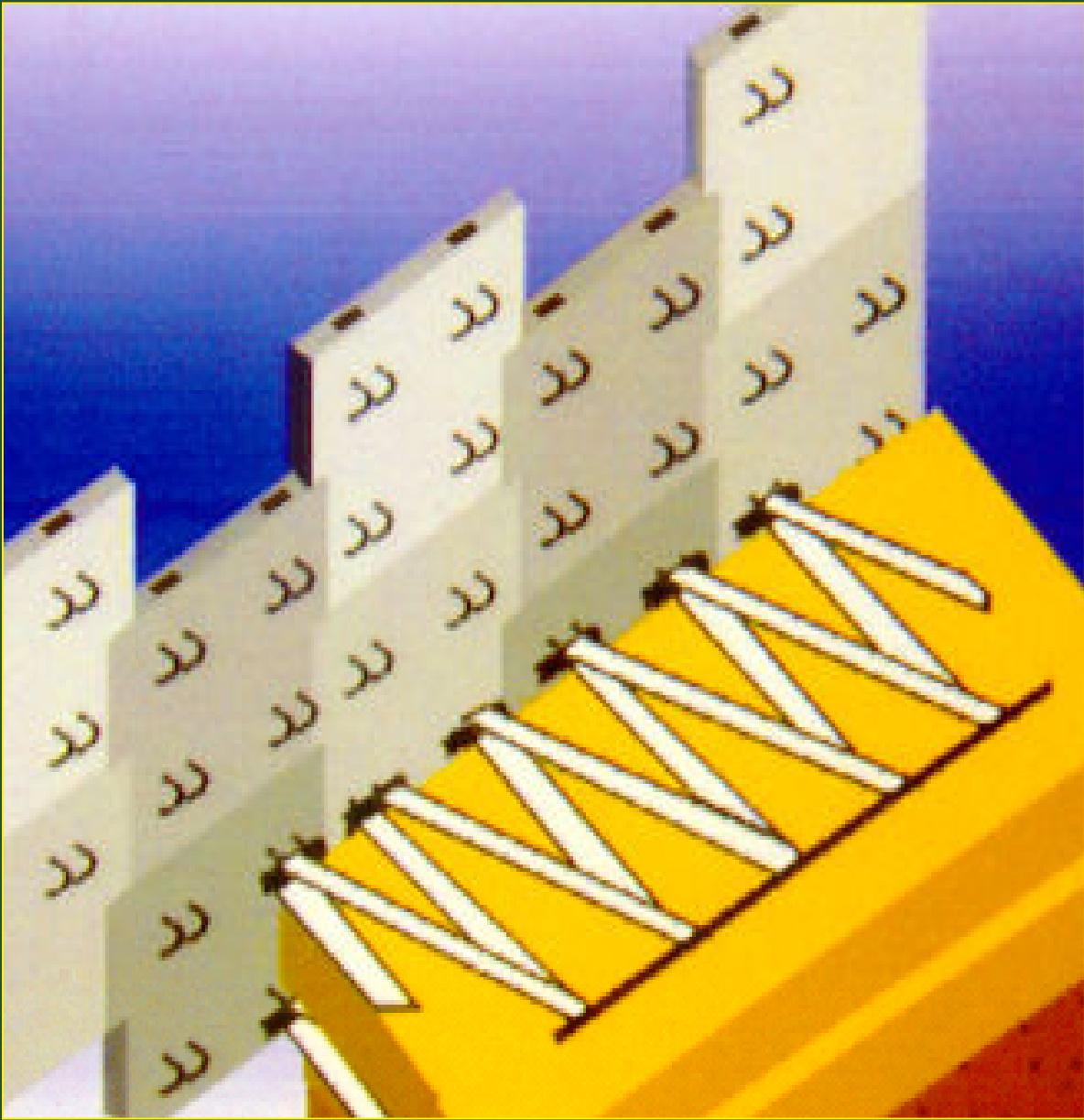

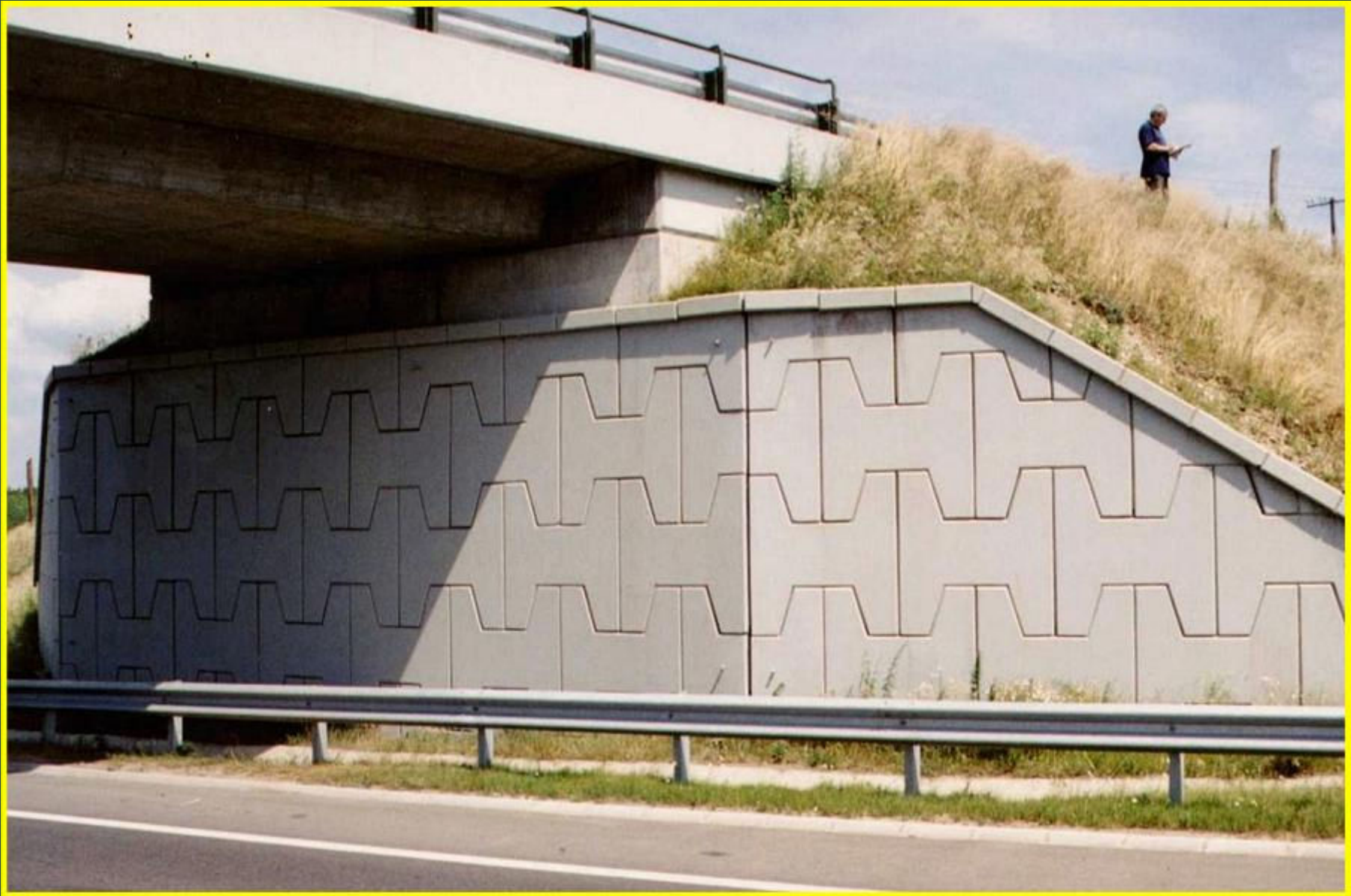

**A leggyakrabban
alkalmazott hídfőtípus**

**Az jó talajra állított
alaptesten ülő
homlokfal
kevesebbet
süllyed, mint a töltés, s
vele a szalagok,
így a befogott szalagok
külpontos húzást
kapnak.**

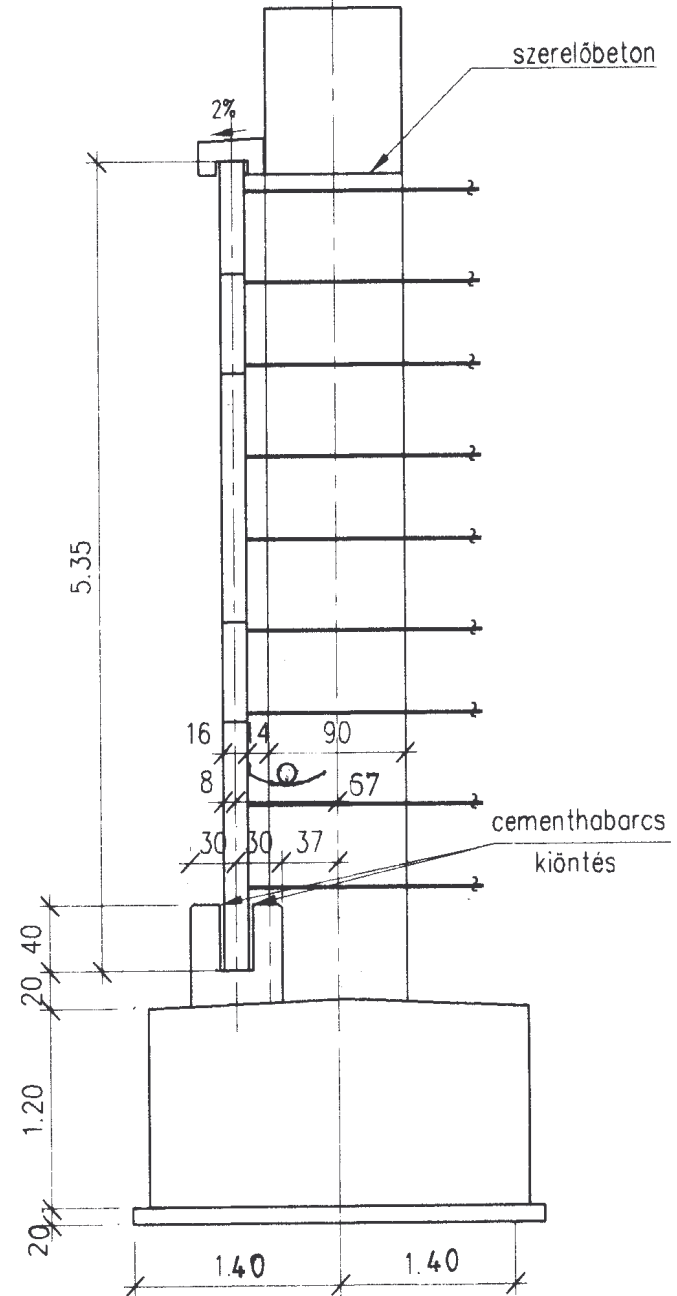

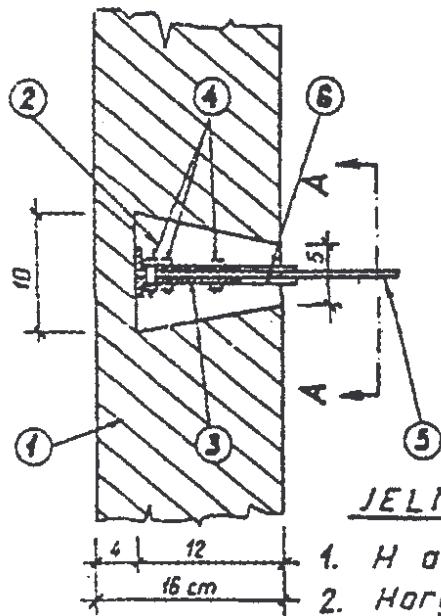

A-A metszet
(Homloklop hátulnézetben)

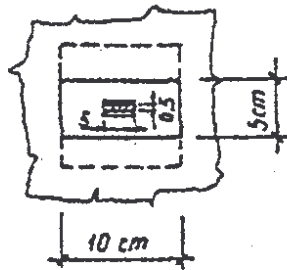

JELMAGYARÁZAT:

1. H alakú vb. elem
2. Horgonyfészek (pc. habarccsal kitöltve)
3. Szorító lemez-pár (4 db. $\phi 8$ furattal)
4. Szorító csavarok (M8x30)
5. Horgonyrúd (50x5 m/m km)
6. Gumszalag betétek

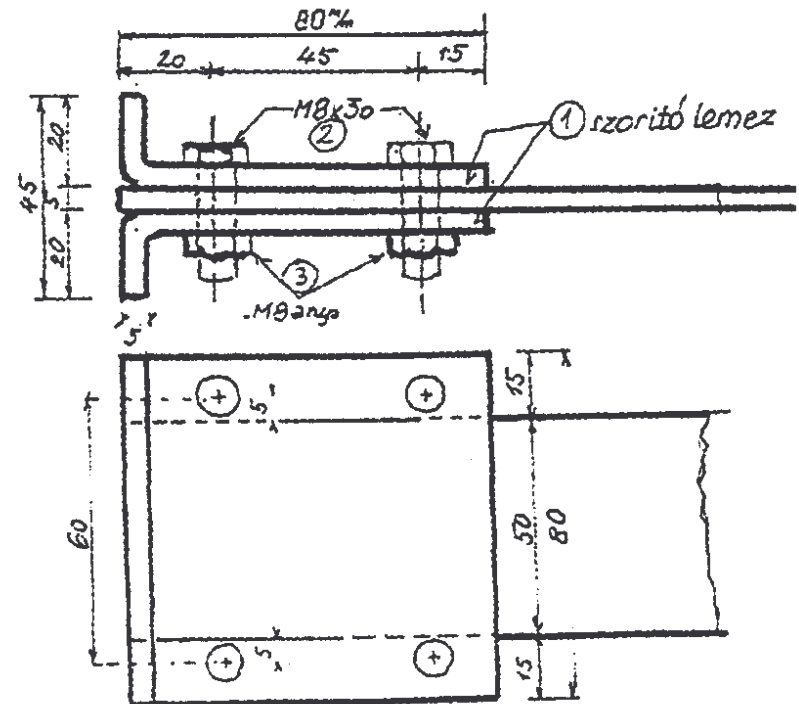

M1 Győrt elkerülő
szakasz

Leomlott hídfő



2.sz. főút horgonyzásos megerősítés



Hátra-
horgonyozott
bordás
megtámasztás

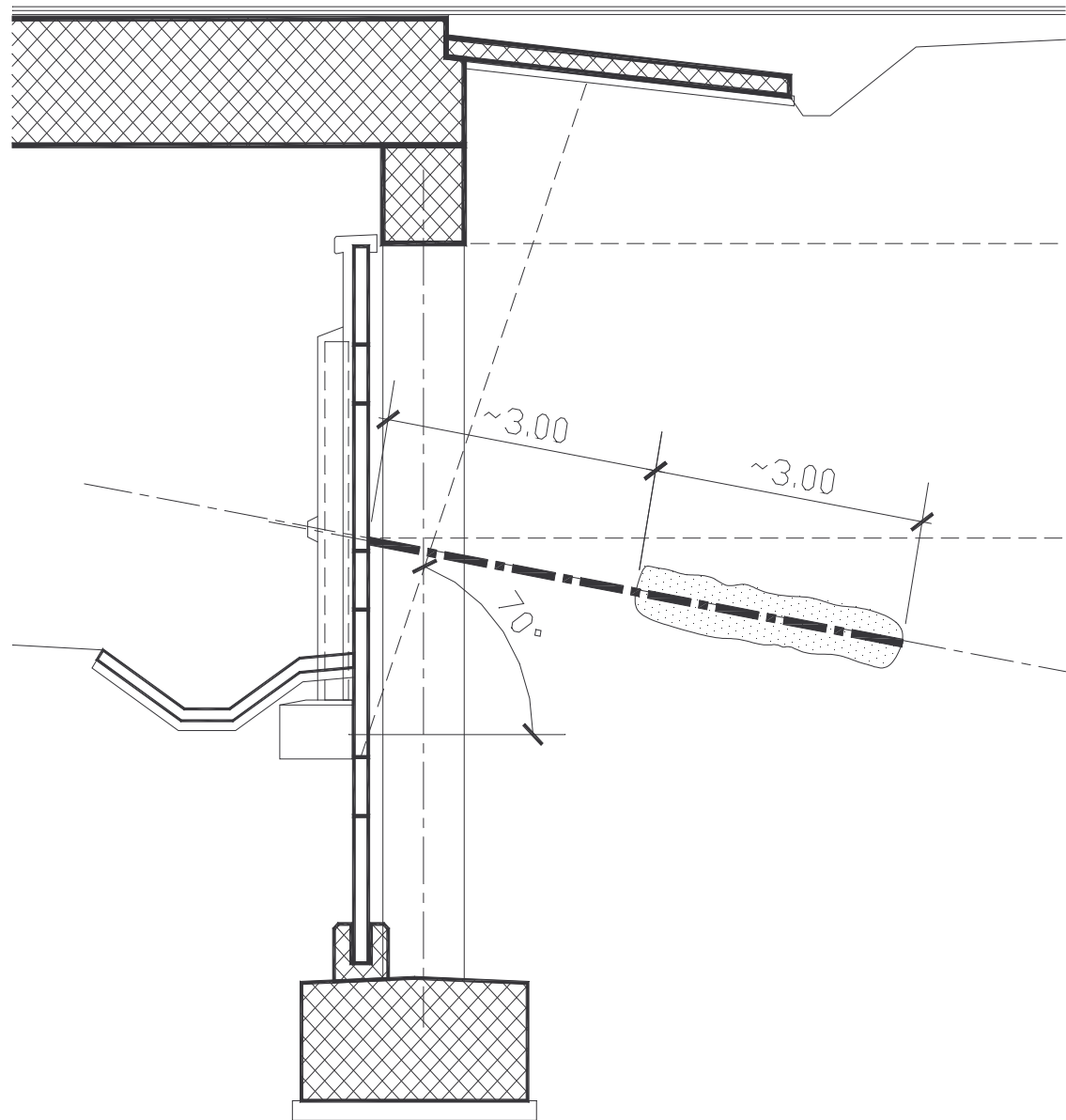

M1 Győrt elkerülő szakasz Elkészült támpilléres megtámasztás

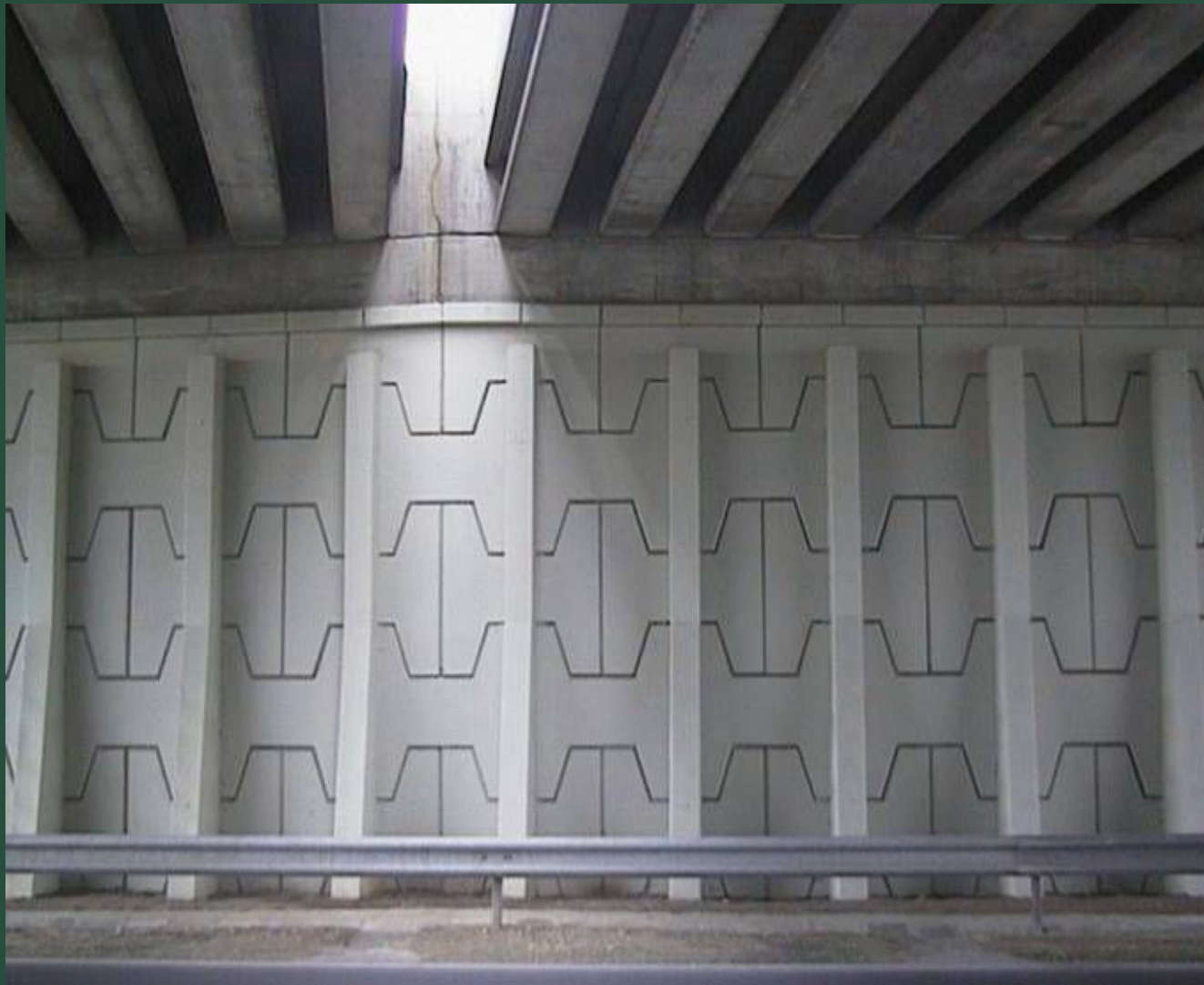

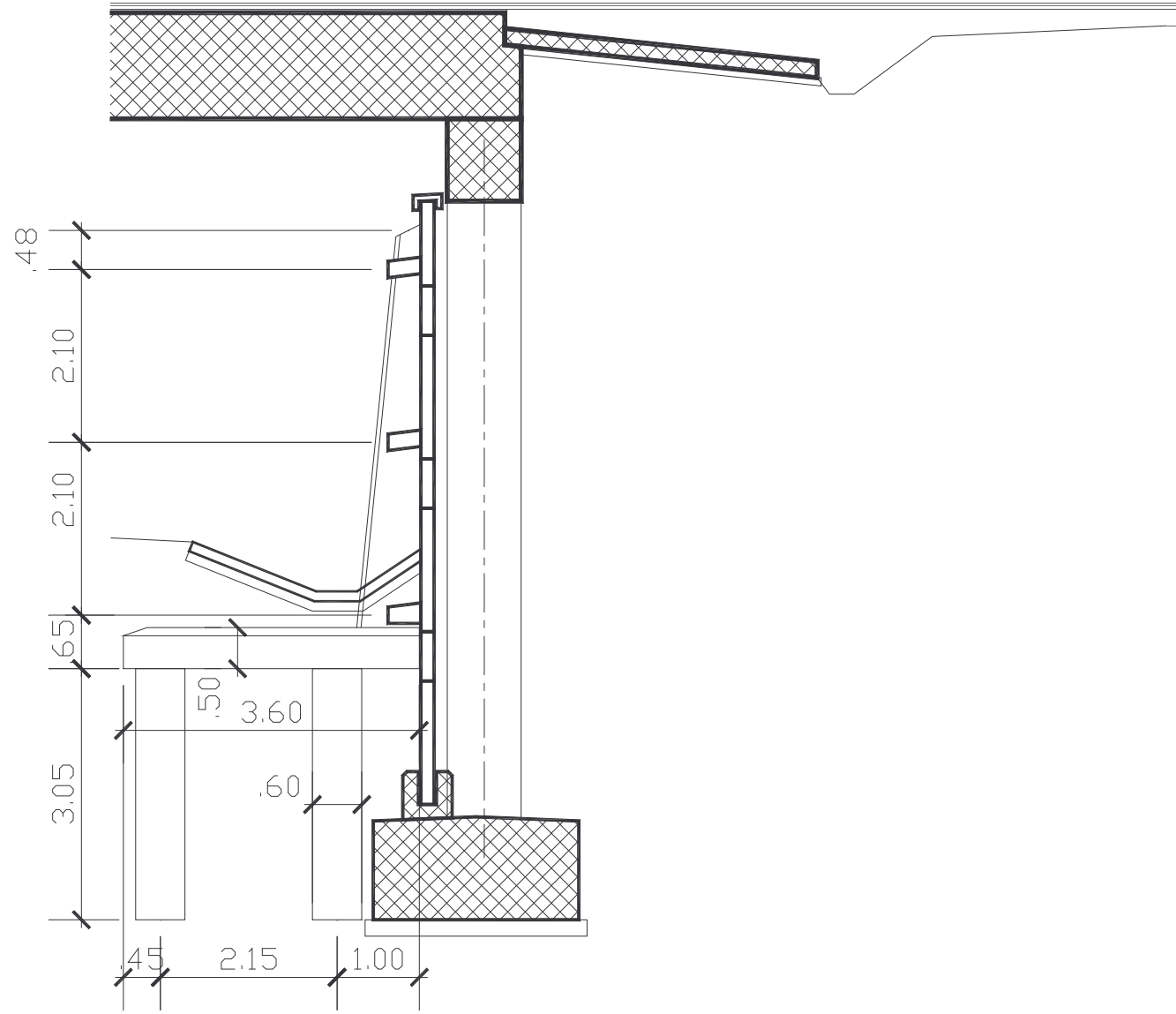

Magyar-
szlovén
vasút-
vonal
georácossal
erősített
talaj-
támfal
minta-
kereszt-
szelvénye

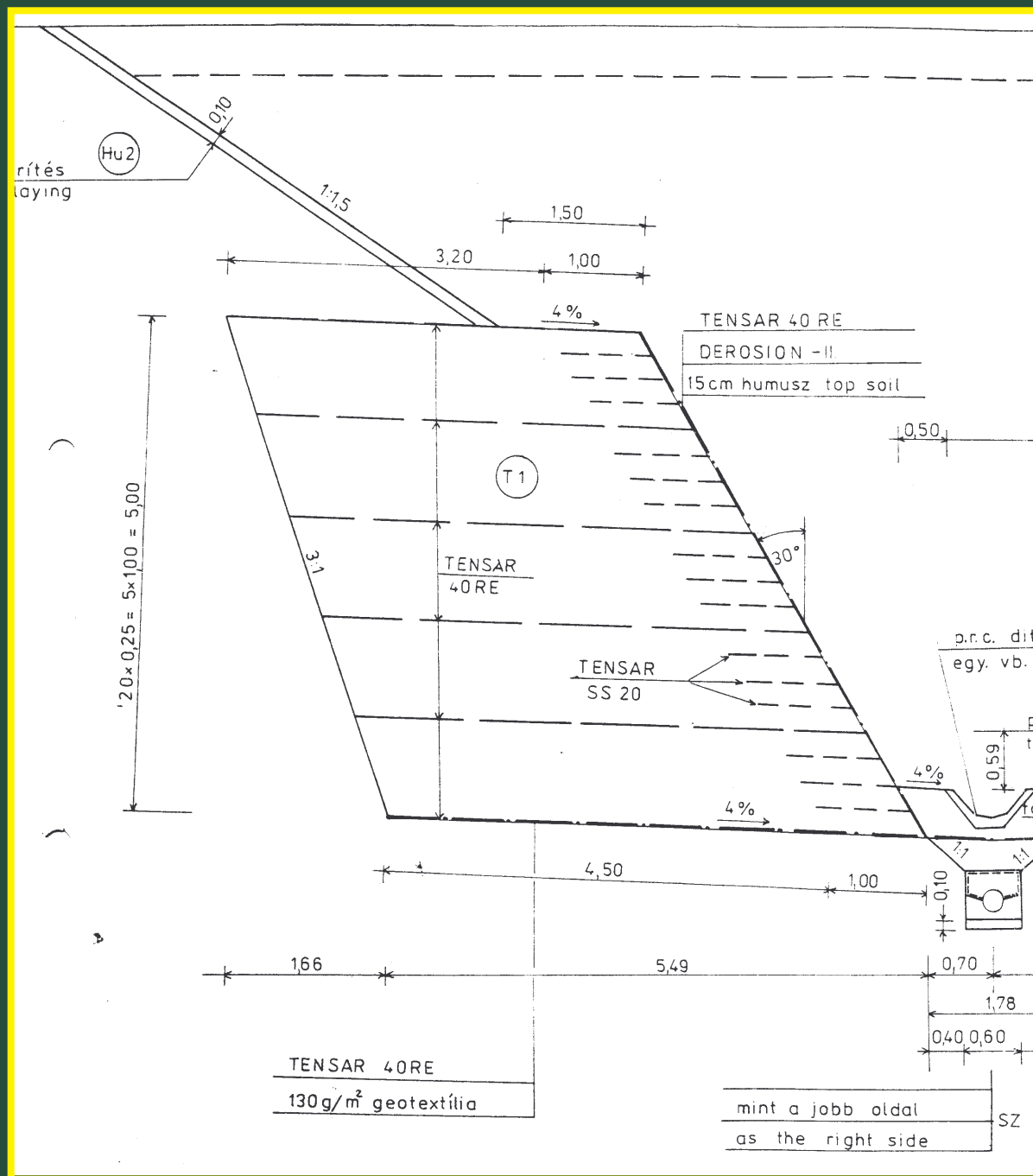

Georáccsal erősített talajtámfal a magyar szlovén vasútvonalon







Magyar-Szlovén Vasútvonal erősített rézsű







M7 autópálya
Bszárszó – Ordacsehi
Terra-Trel támfal
Pannon-Freyssinet





M7 autópálya
Bszárszó – Ordacsehi
Terra-Mesh támfal
Pannon-Freyssinet



M7 autópálya Bszárszó – Ordacsehi
Homlokelemes erősített talajtámfal
TENSAR – GRADEX Kft.







Cellafal



Szegezett fal

Szegezett fal készítése

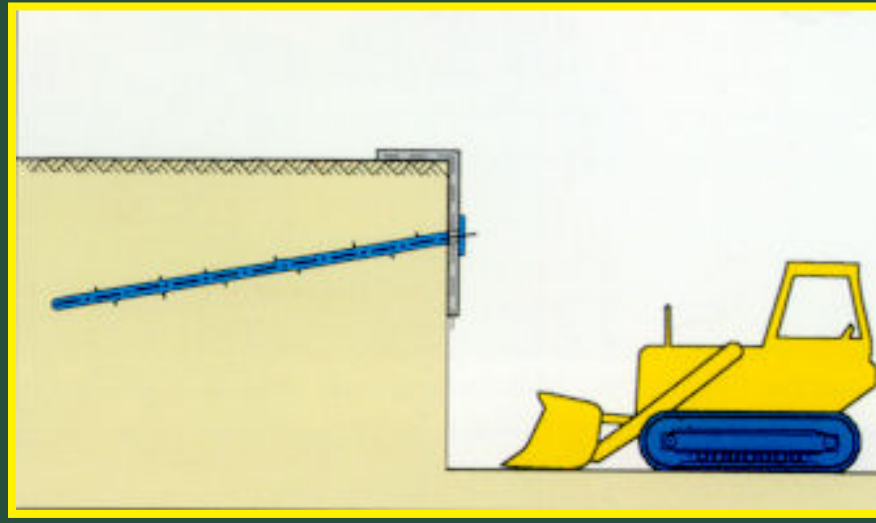
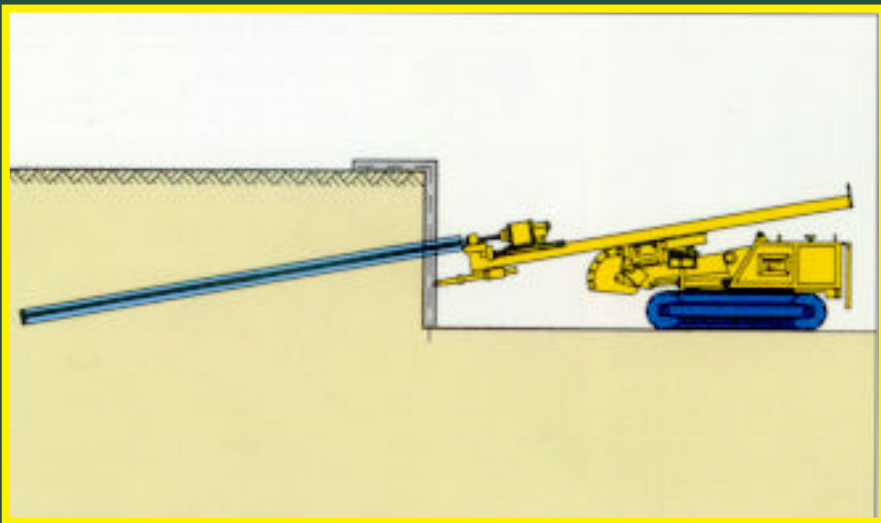
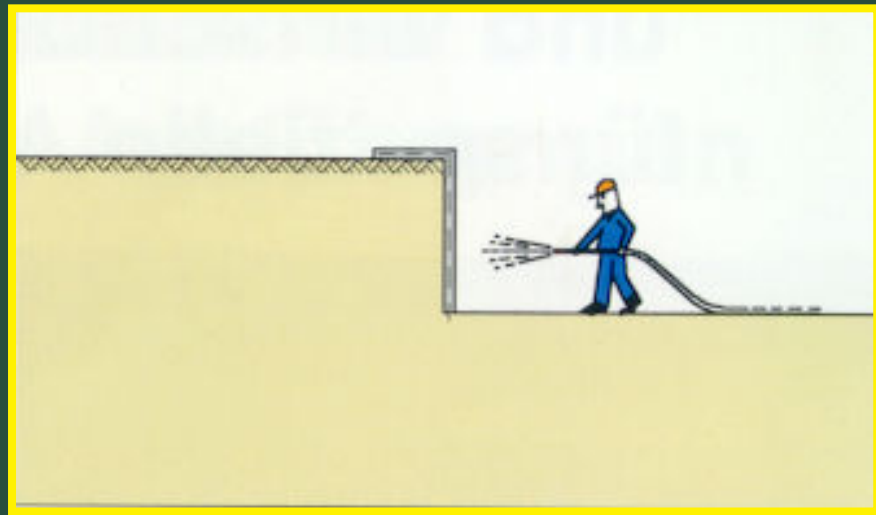
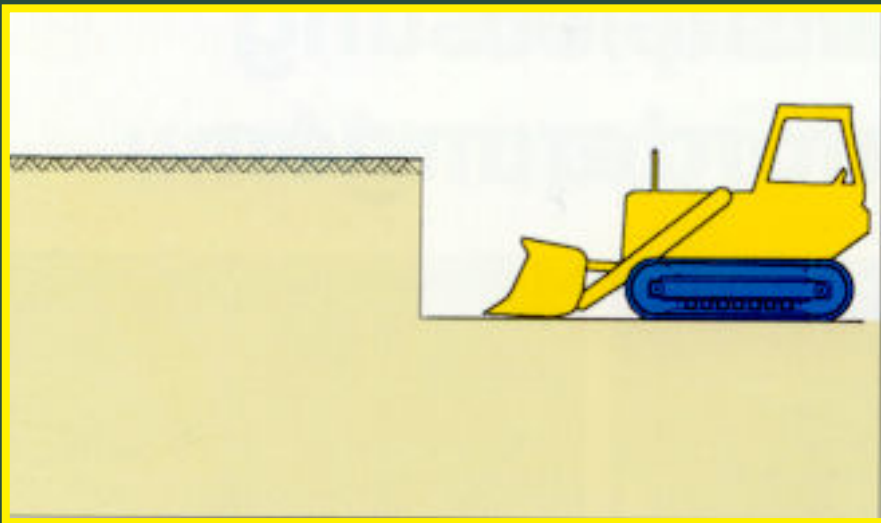











Tartós talajszeg

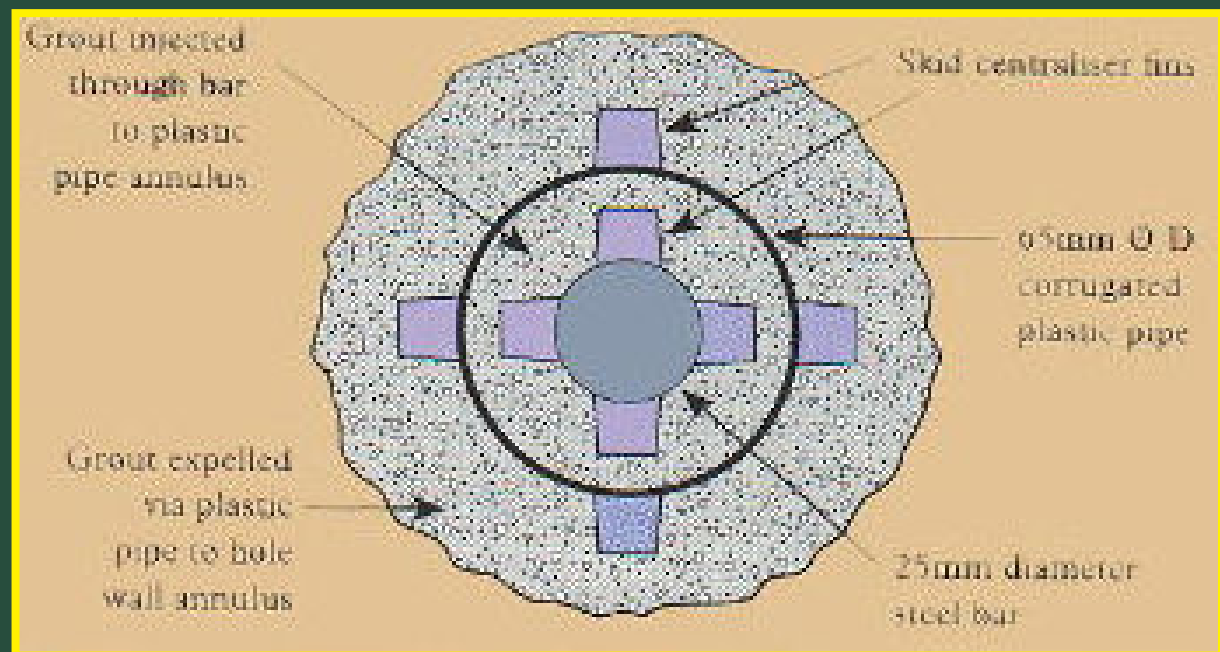
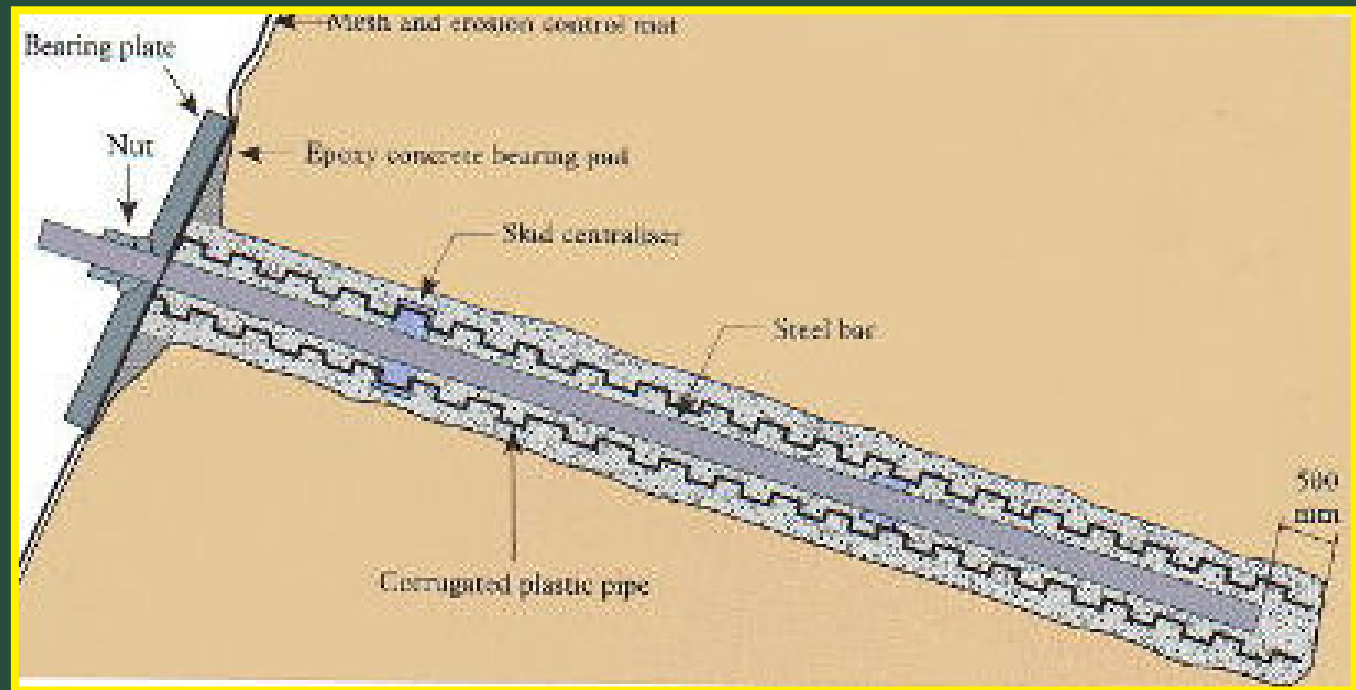



Nyerges-
újfalu
szegezett
fal