

Doka Xtra

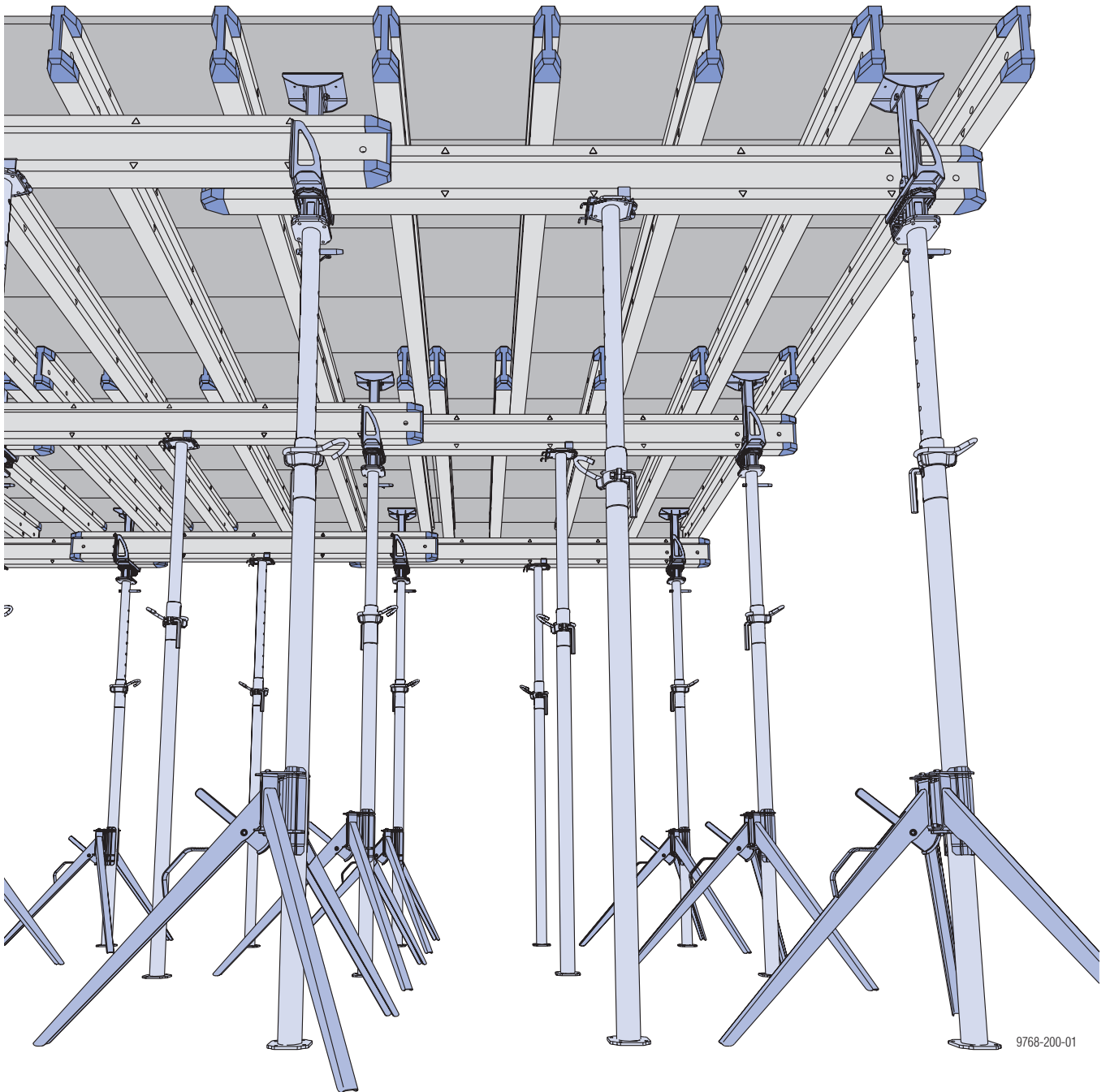

9768-200-01



Important notice:

For safe use of our products, please observe all relevant regulations issued by the local health and safety authorities in the country in which you are operating.

Certain illustrations in this brochure show the situation during formwork assembly and are therefore incomplete from the point of view of safety.

The instructions for function and use of the formwork given in this brochure must be strictly adhered to. If any deviations from these instructions are contemplated, revised static calculations must be produced for checking.

All materials must be inspected before use to ensure that they are in a safe condition. Any components that are damaged, deformed, or weakened due to wear, corrosion or rot must not be used.

Use only original Doka components as replacement parts.

Combining our formwork systems with those of other manufacturers could be dangerous and therefore requires special checking.

If required, we can provide trained personnel to give on-site instruction in use of the formwork.

We reserve the right to make alterations in the interests of technical progress.

All dimensions given in cm unless otherwise indicated.

© by Doka Industrie GmbH, A-3300 Amstetten

Contents	Page
Product description	4
System logic.....	6
Instructions for assembly and use	8
Adaptability	12
Floor formwork around edges / safety railings	13
Combining Doka table systems.....	14
Transporting, stacking and storing	16
Repropping, concrete technology and striking	18
Doka service offerings.....	20
Formwork planning with Tipos	21
Component overview.....	22

Product description

Doka Xtra Floor System - the manhandled system with integrated "stripping logic"

With its integrated stripping logic, Doka Xtra makes for a swift, easy workflow:

- pre-defined formwork-stripping operation
- optimised site logistics - now only one single length of beam (2.65 m)
- reduced commissioning quantities - approx. 75% of the component parts can be struck at an early stage
- less wear-and-tear on the equipment used

Further advantages:

- combines the advantages of flexibility and a defined increment-grid - easy accommodation to walls and columns
- for shoring heights of up to 5.50 m
- any type of form-facing can be used
- no need to measure up

Small number of system components - all perfectly co-ordinated

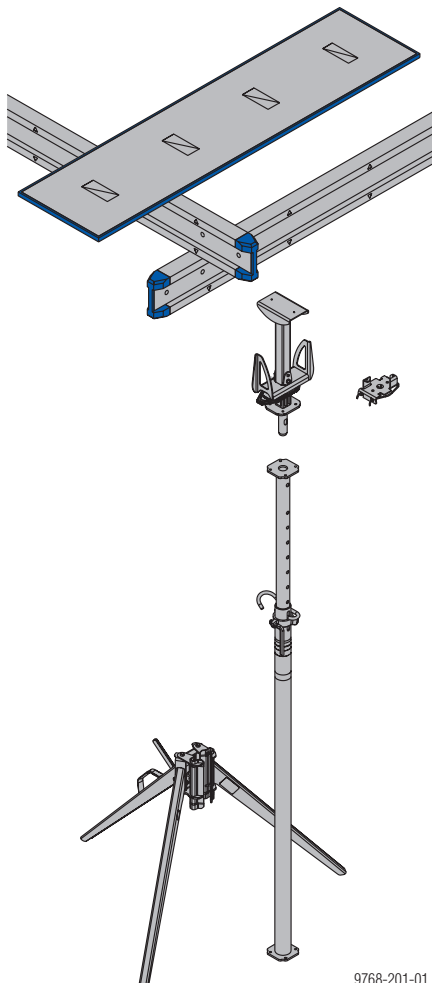

9768-201-01

Dokadur panel

- special surface coating for superb-quality concrete faces
- can be used on both sides
- all-round edge protection for long lifespan
- improved workplace safety thanks to reduced risk of slippage
- easy to clean, with high-pressure spray cleaner
- space-saving storage and handling

Doka beam H20 top 2.65m

- only one length of beam for both primary and secondary beams
- innovative end-reinforcement for reduced damage and long service life
- pre-defined positioning points as reference marks for setting-up and checking the formwork

Doka Xtra head

- integrated quick-lowering function for minimising damage when striking
- keeps props - and thus whole system - stable during formwork removal

Supporting head H20 DF

- easy to mount to the floor prop
- for securing intermediate props to the H20 beam

Doka floor props Eurex

- type-tested to EN 1065
- high load-bearing capacity
 - Eurex 20: 20 kN
 - Eurex 30: 30 kN
- when the floor props are used for temporary re-propping, their permitted load-bearing capacity is 10 kN higher
- this 10 kN increase in the permitted load-bearing capacity also applies when the props are used with Xtra heads, under the following condition:
 - permitted floor-prop extension length: max. extension length less 50 cm overall height of Xtra head
- numbered pegging holes, for easier height adjustment
- special thread geometry, which makes the prop easier to release even when it is under high load
- elbowed fastening clamps, reducing the risk of injury and making the props easier to operate

Removable folding tripod

- for holding floor props upright
- swing-out legs allow flexible placement in constricted situations such as along edges and in corners

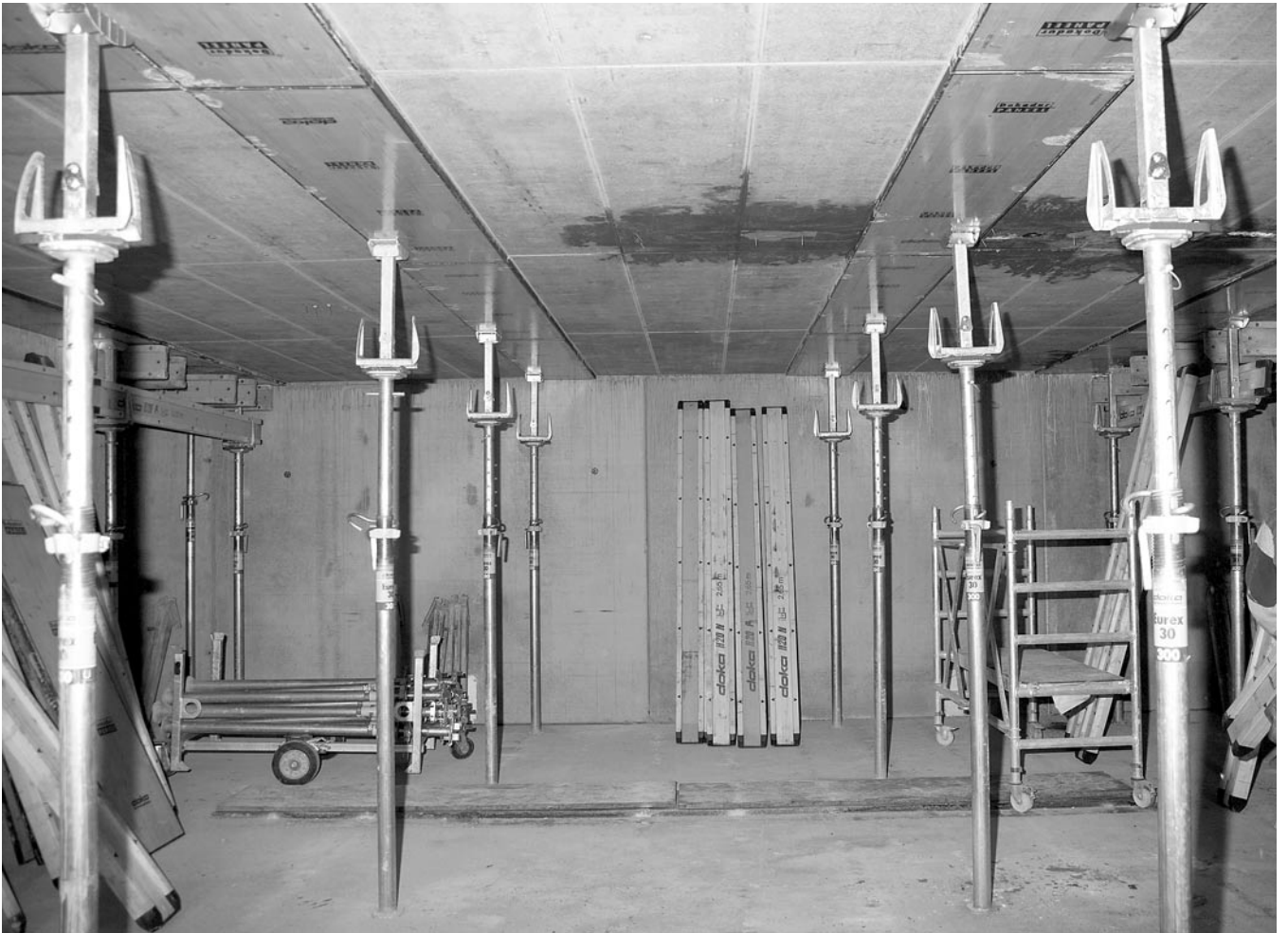
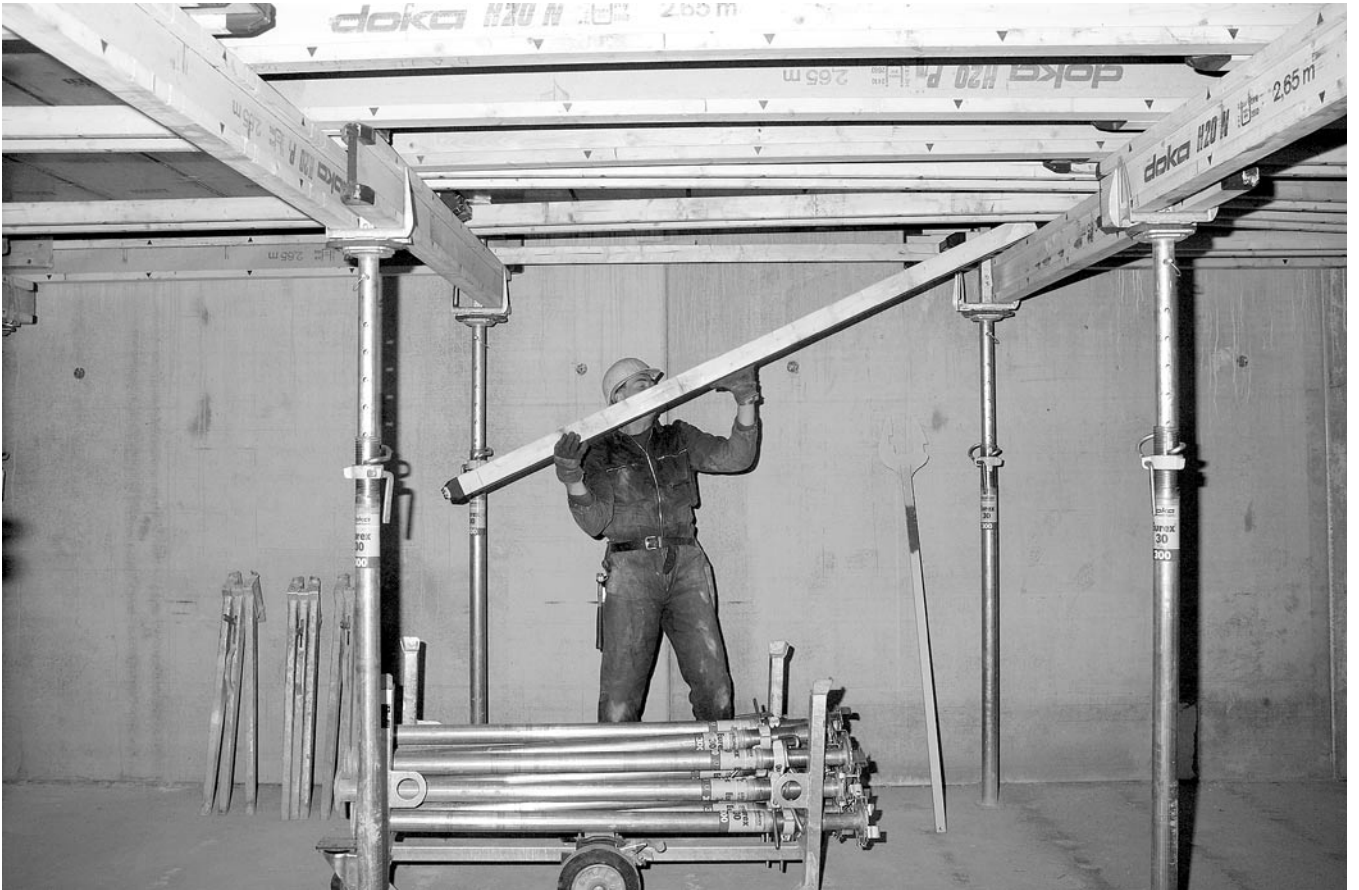

System logic

The straightforward logic underlying the Doka Xtra system means that there is no need for planning and operations scheduling work.

Selecting the floor props

Depending on the **thickness of slab**, either of 2 types of floor prop may be selected:

Thickness of slab	Floor prop
up to 23 cm	Eurex 20
up to 32 cm	Eurex 30 ¹⁾

¹⁾ Eurex 20 props can also be used as intermediate props here. However, to prevent mix-ups, we recommend using only Eurex 30 floor props.

Important note:

Floor props fitted with an Xtra head must not be used extended to their full length!

Permitted floor-prop extension length: max. extension length less 50 cm overall height of Xtra head

Example: Floor prop Eurex 20 300 is allowed to be extended to max. 250 cm.

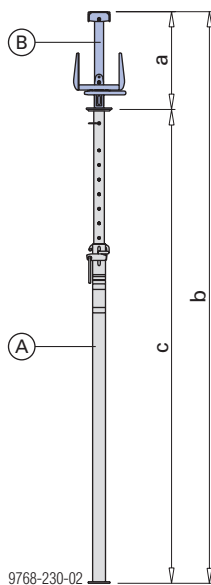

- a ... overall height of Xtra head (50 cm)
- b ... max. extension-length of floor prop (on Eurex 20 300: 300 cm)
- c ... permitted extension-length of floor prop (on Eurex 20 300: 250 cm)

A Doka floor prop (e.g. Eurex 20 300)

B Doka Xtra head

Primary and secondary beams

The **Doka beam H20 top** with a beam-length of **2.65m** is used for both the **primary** and **secondary beams**.

Used as:	Length of beam
Primary beam	2.65m
Secondary beam	2.65m



The primary beams should be orientated at right angles to the direction of an uneven length of room (5 m, 7 m, 9 m, etc.). This makes more efficient use of the potential of the system.

Format of the formwork sheets

With its dimensions of **200x50cm** (21 or 27mm thick), the Dokadur panel fits exactly into the increment-grid of the Doka Xtra system.



Spacing and positions of the component parts

No matter whether the beams are resting on, between or next to the marks, the maximum spacing is always plain to see.

You can tell at a glance whether the formwork has been erected correctly, and without having to measure up.

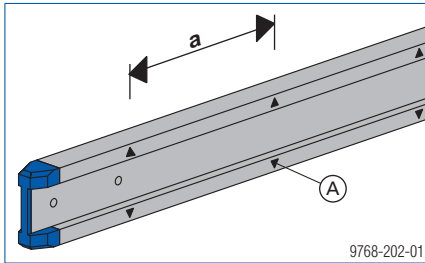

a ... 0.5 m

A Mark

32.5 cm (marks at either end of the beam)

- max. beam cantilever
- 1 mark = 0.5 m**
- max. spacing of secondary beams
- 2 marks = 1.0 m**
- max. spacing of props
- 4 marks = 2.0 m**
- max. spacing of primary beams

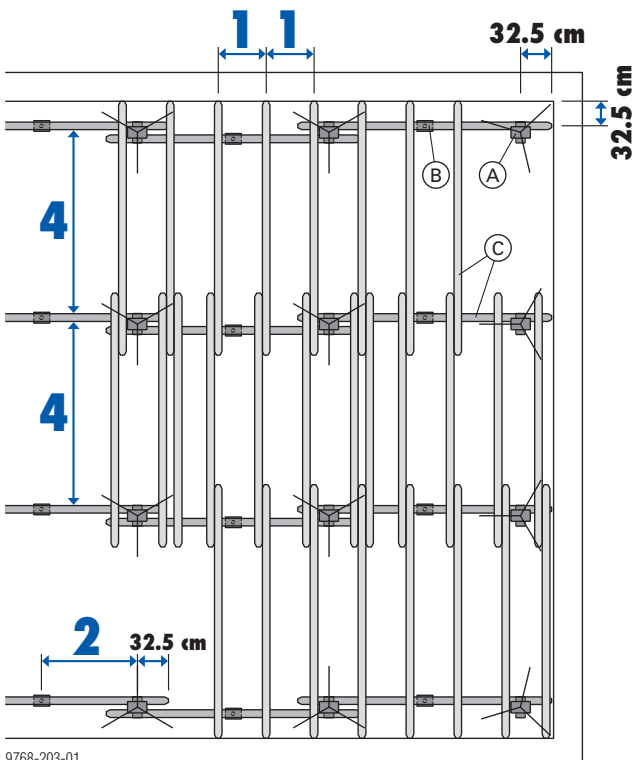

A Floor prop Eurex + Doka Xtra head + Removable folding tripod

B Floor prop Eurex + Supporting head H20 DF

C Doka beam H20 top 2.65m

Optimising the structural design with regard to equipment quantities

The following tables make it possible to design Doka Xtra for thicker slabs as well.

The **spacing of the primary beams** is ascertained with reference to the type of floor prop and the thickness of the slab.

Floor prop Eurex 20	
Thickness of slab	Max. spacing of primary beams
23 cm	2.00 m
25 cm	1.90 m
26 cm	1.80 m
28 cm	1.70 m
30 cm	1.60 m
32 cm	1.50 m
34 cm	1.40 m
37 cm	1.30 m
40 cm	1.20 m
44 cm	1.10 m
48 cm	1.00 m

Floor prop Eurex 30	
Thickness of slab	Max. spacing of primary beams
32 cm	2.00 m
34 cm	1.90 m
36 cm	1.80 m
38 cm	1.70 m
40 cm	1.60 m
43 cm	1.50 m
46 cm	1.40 m
49 cm	1.30 m
53 cm	1.20 m
58 cm	1.10 m
64 cm	1.00 m



Instructions for assembly and use

Important note:

As well as the instructions given here, the section headed "Repropping, concrete technology and striking" MUST be followed.

Formwork erection

Putting up the floor props

- ▶ Place primary and secondary beams along the edges.
The marks on the beams show you the maximum spacings:
 - 4 marks for primary beams
 - 4 marks for props with removable folding tripods
- ▶ Put up each removable folding tripod.
- ▶ Roughly adjust the height of the floor prop, using the fastening clamp.
The pegging holes are all numbered, which makes it easier to adjust the props to the same height.
- ▶ Push up the lowering unit of the Xtra head and fix it to the wedge with a blow of the hammer.

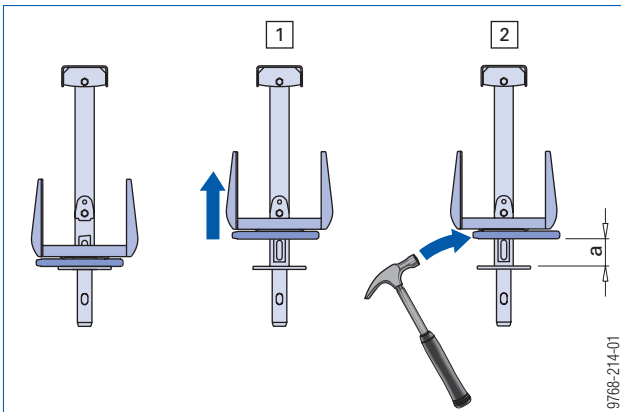

a ... 7 cm

 Clearance between wedge and head-plate: 7 cm

- ▶ Insert the Xtra head into the floor prop and secure it with a Spring-locked connecting pin 16 mm.

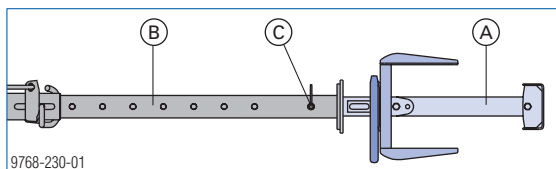

- A Doka Xtra head
- B Doka floor prop
- C Spring-locked connecting pin 16 mm

- ▶ Place each floor prop, with an Xtra head already mounted on it, into a removable folding tripod and fix the prop in place with the clamping lever.



The Xtra heads that will be under the primary beams next to the wall(s) must be turned inwards so that they can be knocked undone when the time comes to strike the formwork.

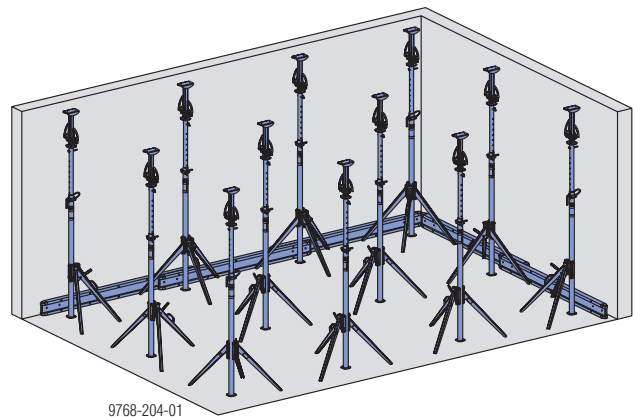
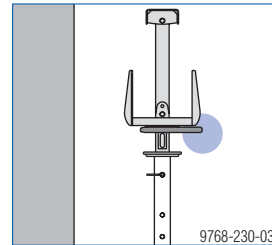

Inserting the primary beams

- ▶ Using beam-forks, place the primary beams into the Xtra heads.
The Xtra heads can hold both single beams (on edge-of-room props) and double beams (at overlaps).
- ▶ Adjust the primary beams to the correct floor-slab height.

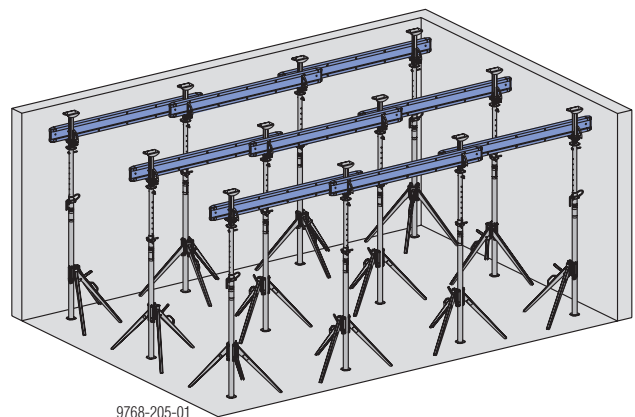

Putting up the intermediate props



Warning!

➤ It is not permitted to set down any loads on the floor-slab formwork (e.g. beams, panels, reinforcements) until the intermediate props have been set up!

➤ Place the Supporting head H20 DF on the inside tube of the floor prop and secure it with the integral spring-steel stirrup.

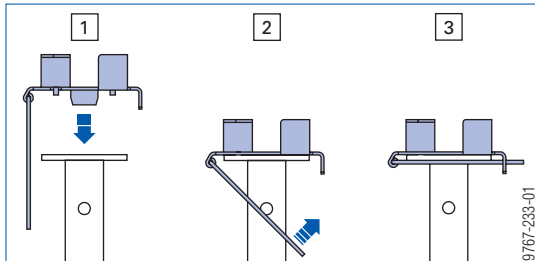

➤ Put up the intermediate props.

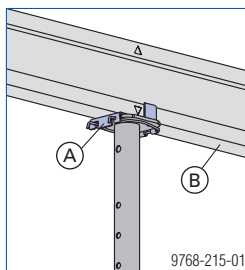

A Supporting head H20 DF

B Doka beam H20 top

Maximum prop spacing: 2 marks apart

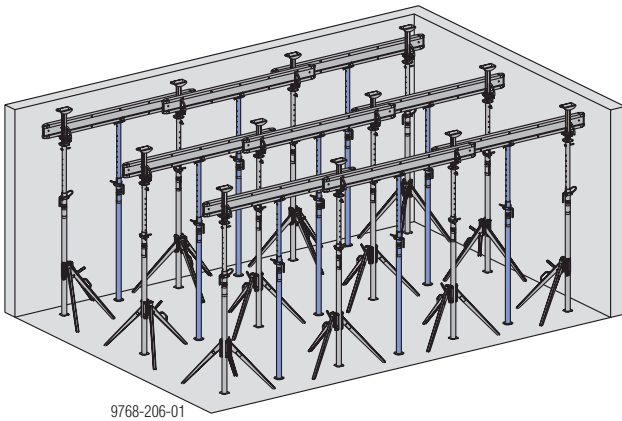

Placing the secondary beams on the primary beams

➤ Use the beam forks to place the secondary beams on the primary beams, with an overlap. Maximum spacing of secondary beams: 1 mark



Be sure to place a beam (or double beam) wherever there is to be a joint between the Dokadur panels.

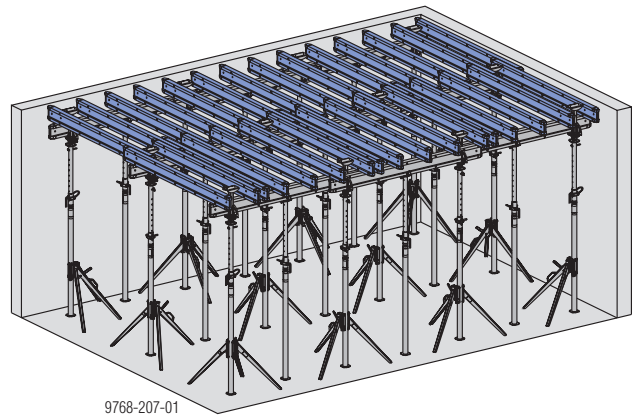
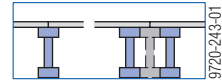

Laying the Dokadur panels

➤ Mount guard rails around all exposed edges.
➤ Lay the Dokadur panels at right angles to the secondary beams.

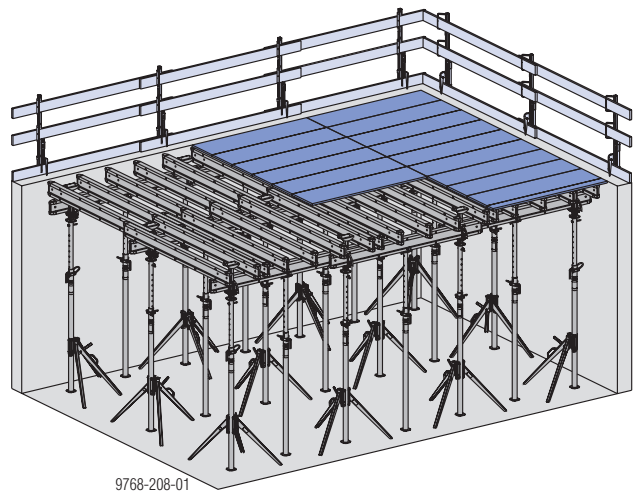

➤ Spray the Dokadur panels with parting agent.

Pouring

To protect the surface of the form-facing, we recommend using a vibrator with a protective rubber cap.

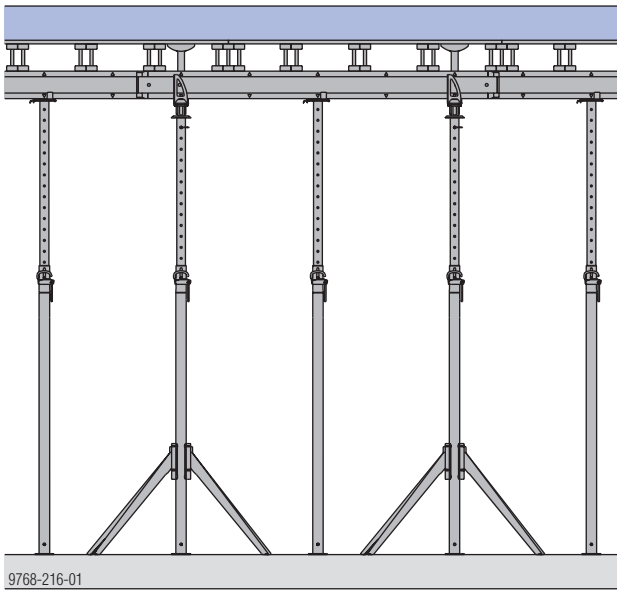

After pouring

► Remove the folding tripods.

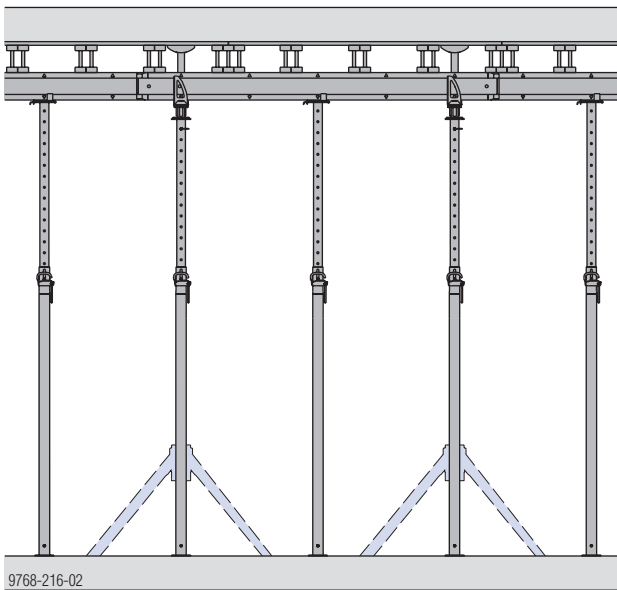

Early striking

► Observe all stipulated stripping times!

Removing the intermediate props

► Remove the intermediate props and put them in the stacking pallet.

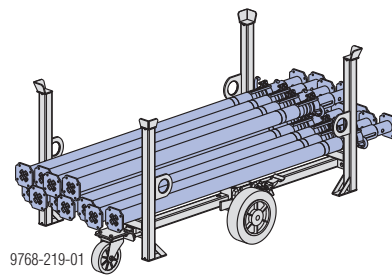
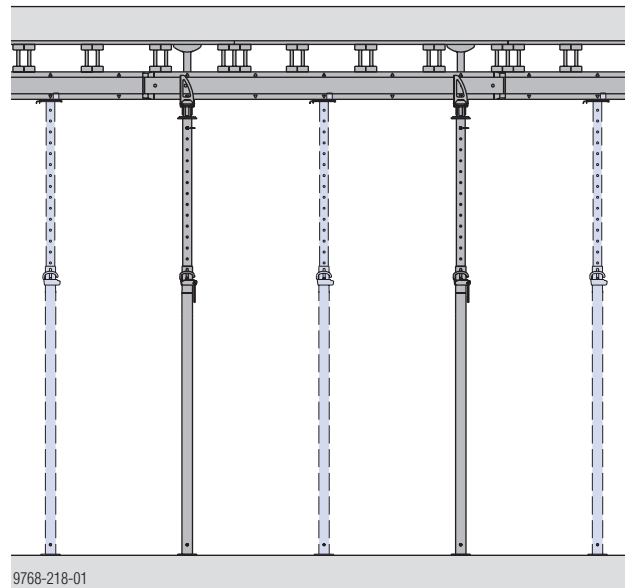

After the intermediate props have been removed, there remain only props spaced 2.0 m apart in both directions. This leaves enough space to manoeuvre a wheel-around scaffold without difficulty.



The **Wheel-around scaffold DF** is ideal for **striking the formwork from floor-slabs above rooms of medium height.**

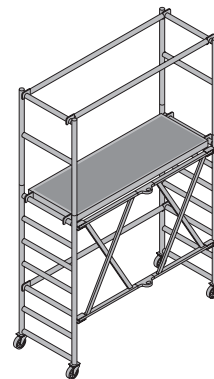

- collapsible wheelaround platform made of light alloy
- variable working heights of up to 3.80 m (max. platform height: 1.75 m)
- platform width: 0.80 m

Lowering the floor-slab formwork

- Lower the floor-slab formwork by striking the wedge on the Xtra head with a hammer.

The floor props, with the Xtra heads, remain clamped in position.

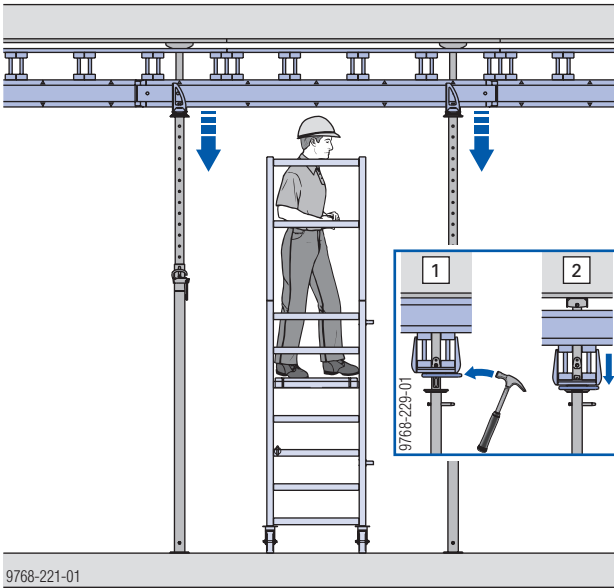

Removing parts that are no longer needed

- Turn the secondary beams over onto their sides, pull them out and put them in the stacking pallet.
- Take out the Dokadur panels and put them in the stacking pallet. Dokadur panels that are held in place by the floor props with Xtra heads must be left in position.

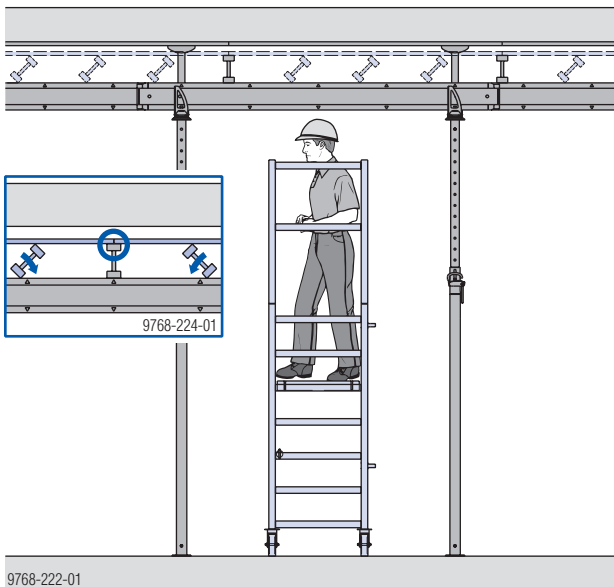

9768-222-01

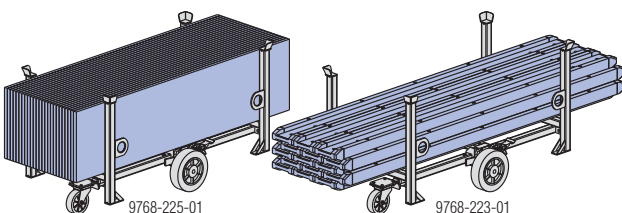

- Remove the remaining secondary beams and the primary beams, and put them in the stacking pallet.

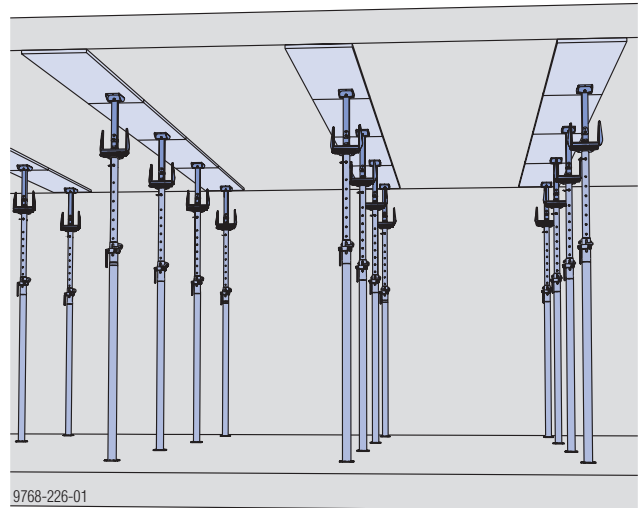

Removing the auxiliary shoring

- Loosen the floor prop, and take out the Dokadur panel at the same time. Put the floor props and Dokadur panels in the stacking pallet.

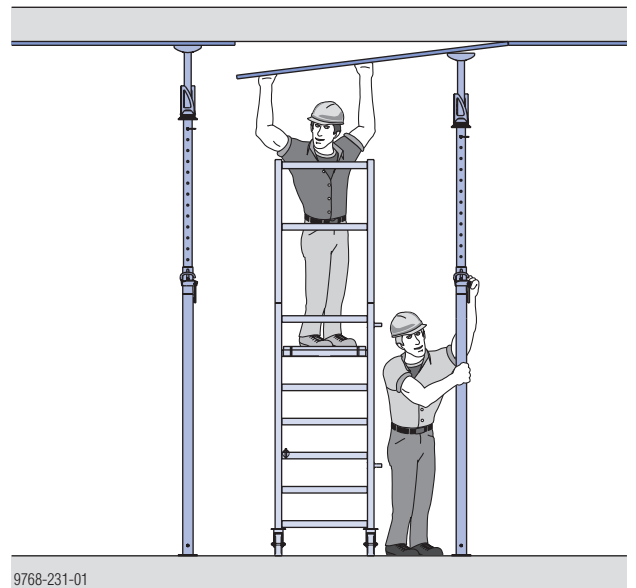

9768-231-01

Repropping

- Before pouring the next floor-slab (i.e. above the one that has just been stripped), put up reshoring props.

Adaptability

Closures and adjustments

Infill zones are solved within the system - with no special accessories needed. The necessary adaptation is made by **overlapping the Doka beams** and inserting **strips of formwork sheeting**.

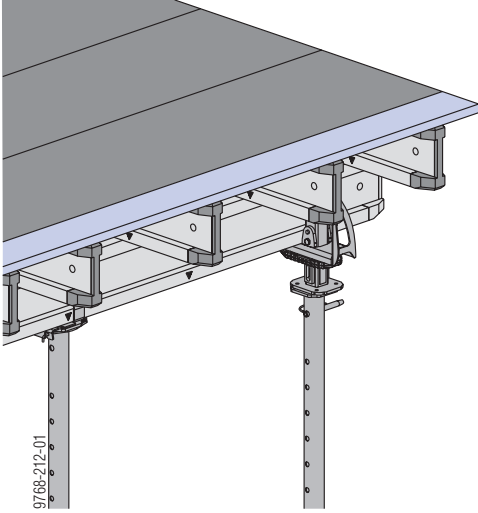

Grid and flexibility - in one system

Doka Xtra also adapts to difficult layouts.

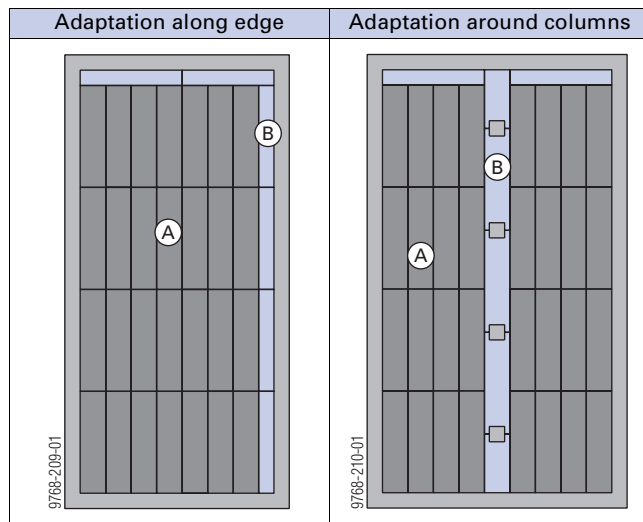
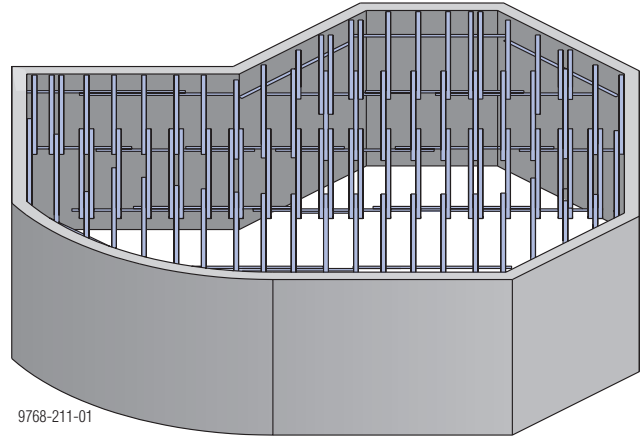

A Dokadur panel

B Fitting boards in the closure zone

Floor formwork around edges / safety railings

It can be advantageous to combine Doka Xtra with Dokamatic tables, particularly in edge-zones. The formwork for downstand beams and stop-ends, and the safety railings, can all be integrated in the edge tables.

Without edge floor-beam

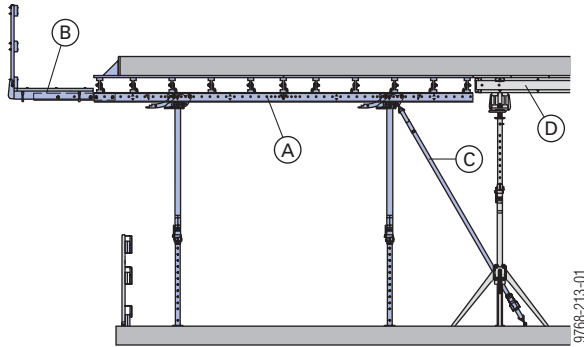

- A Dokamatic table
- B Dokamatic table platform
- C Back-stay
- D Doka Xtra

Using Doka Xtra for edge-zones

If no separate edge tables are available, the following points must be remembered when using Doka Xtra:

- In order to be able to transfer the horizontal forces, the superstructure components must be firmly attached to one another.
- The back-stay can be fastened to either the secondary or primary beam.



Warning!

- For work at dangerous heights, the secondary-beam elements with the working platforms must be preassembled on the ground.
- Where working platforms are erected on cantilevering floor-slab formwork, the formwork must be secured against accidental lift-out.
- Secondary beams with stop-end formwork must be secured against horizontal pull-out.
- In addition, erect guard scaffolding beside the structure.

With edge floor-beam

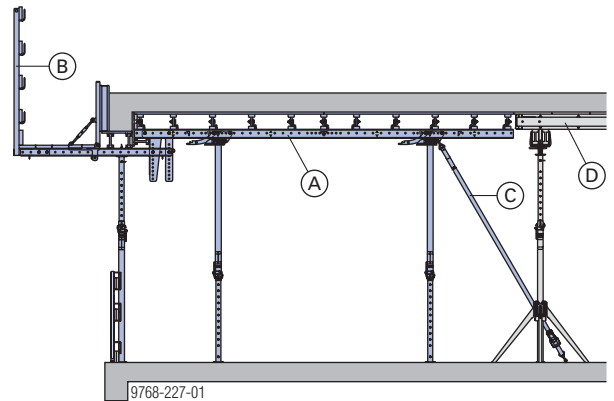

- A Dokamatic table
- B Handrail post T 1.80m
- C Back-stay
- D Doka Xtra

Safety railings with Handrail clamp S

The Handrail clamp S can be mounted anywhere on the formwork beam and on finished concrete floor-slabs.

Clamping range: 2 to 43 cm

The 45°-angled loops mean that guard-rail boards can be inserted in either direction.

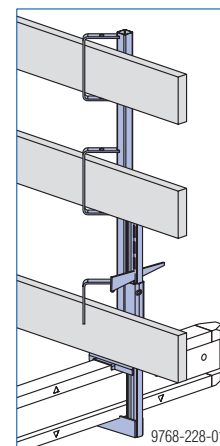

Please follow the instructions in the "Assembly and utilisation instruction booklet for Doka handrail clamp S".

Combining Doka table systems

Because the superstructures of all Doka floor-slab systems share the same basic structure, they can also be used together on the site.

Dokamatic and Dokaflex tables

The Doka tables are pre-assembled, and save on both labour and crane time. With the shifting trolley plus attachable drive unit, the tables can easily be wheeled across to their next location by just one man working on his own. The system is optimised to give the very shortest forming-times on large areas, and copes well even with varying structural-design and geometrical requirements.



For more information, see the User Information booklets "Dokamatic table" and "Dokaflex Floor System".

Dokaflex 1-2-4

Dokaflex is the fast and versatile floor-slab formwork for any layout - also for downstand beams, stepped floors and filigree slabs. Because the quantities can easily be computed using a slide-rule, no formwork planning is needed. Any type of form-facing can be used, enabling all architectural wishes regarding the concrete surface to be met.



For more information, see the User Information booklet "Dokaflex Floor System".

Dokaflex 1-2-4 and Beam forming support for downstand beams and slab stop-ends

The Beam forming support 20 is the professional way of forming downstand beams and slab stop-ends. The Beam forming support automatically clamps the formwork tight, resulting in clean concrete surfaces and grout-tight edges.



For more information, see the User Information booklet "Dokaflex Floor System".

Notes

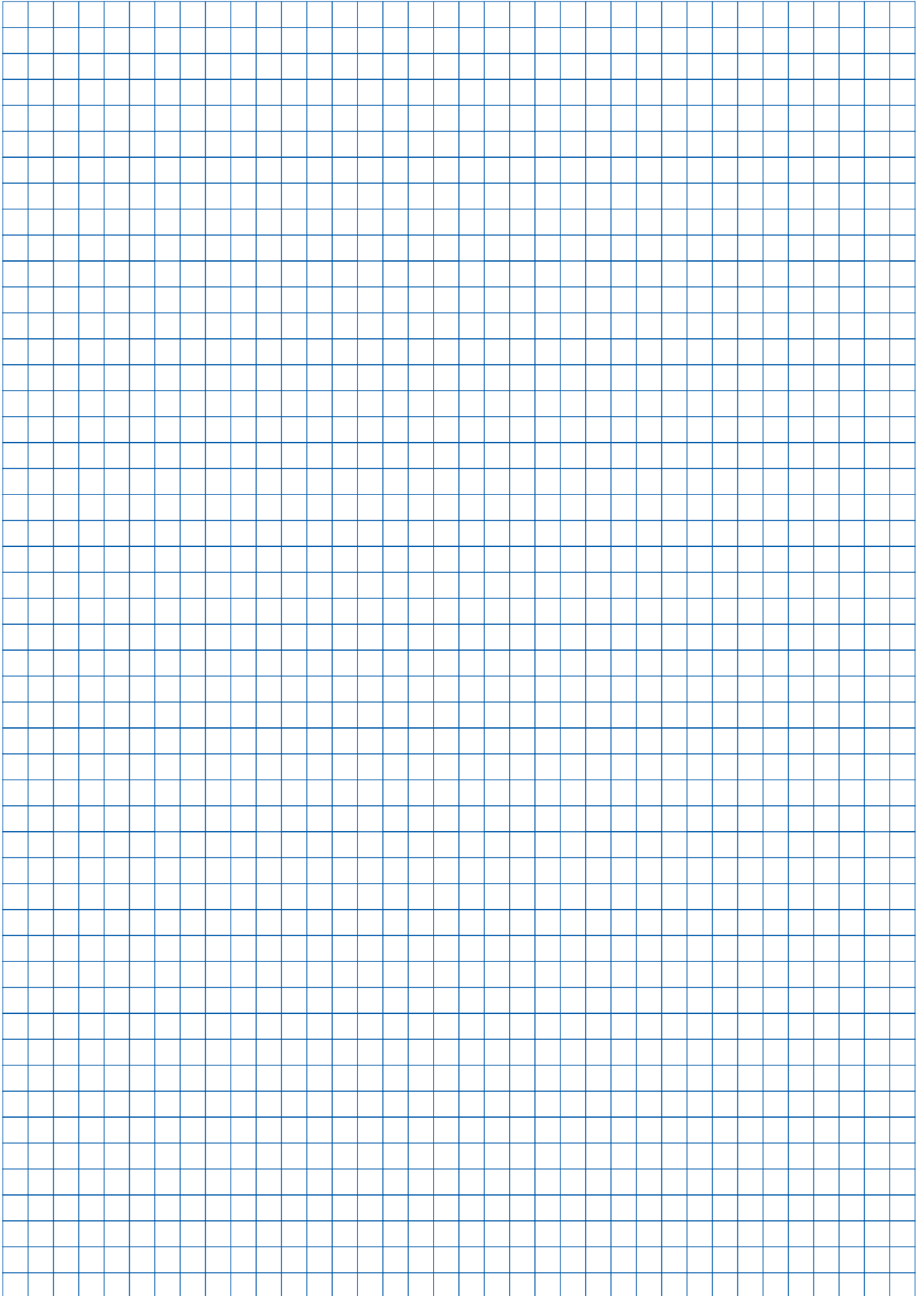
A large grid of graph paper for taking notes, consisting of 20 columns and 40 rows of small squares.

Transporting, stacking and storing

Use the advantages of Doka multi-trip packaging on the site.

Doka offers tried-and-tested help when it comes to streamlining the transport and handling of formwork equipment, by delivering it in multi-trip packaging. Any packaging items that are no longer needed can simply be returned to your nearest Doka branch.

Doka multi-trip transport box 1.20x0.80m galv.

The ideal container for all small components:

- durable
- stackable
- can safely be moved by crane

The Doka multi-trip transport box is used for delivering e.g.:

- Doka Xtra heads
- Supporting heads H20 DF

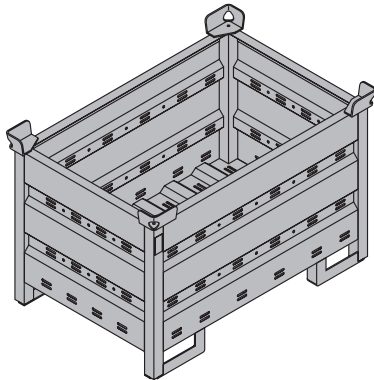

Max. capacity: 1500 kg (15 kN)



Please follow the directions in the instruction manual!

Doka skeleton transport box 1.70x0.80m

The ideal container for all small components:

- durable
- stackable
- can safely be moved by crane

The Doka skeleton transport box is used for delivering e.g.:

- Removable folding tripods
- Handrail clamps S

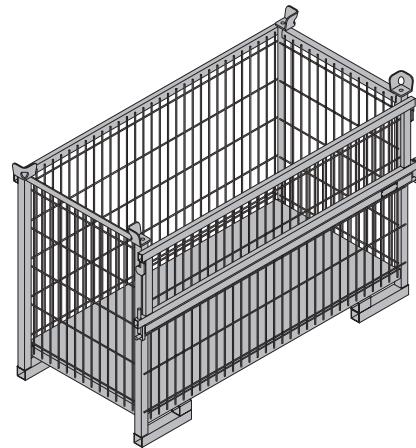

Max. capacity: 700 kg (7 kN)



Please follow the directions in the instruction manual!

Doka stacking pallet 1.55x0.85m

- Ideal for all sizes of floor props, timber formwork beams, Dokadur panels and formwork sheets.
- Galvanised - stackable - safe to lift by crane.

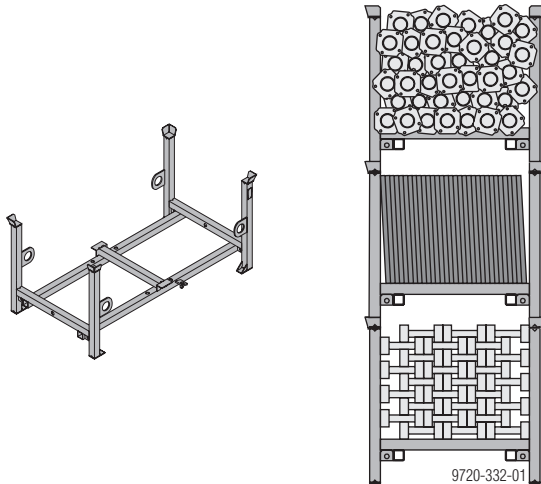

Max. capacity: 1100 kg (11 kN)

Loading capacity of the stacking pallet:

Doka floor props	
Eurex 20 250, 300 and 350	40 units
Eurex 20 400 and 550	30 units
Eurex 30 250 and 300	40 units
Eurex 30 350, 400 and 450	30 units
Dokadur panels	
21mm	32 units
27mm	25 units
Doka beams	
H20 top	27 units



Please follow the directions in the instruction manual!

Bolt-on castor set

The quick-fit bolt-on castor set (with rapid-acting couplings) turns the stacking pallet into a fast and manoeuvrable transport trolley. Its width of only 86 cm makes it easy to manoeuvre through any doorway.

A bolt-on castor set consists of:

- 2 heavy duty wheels, complete (A)
- 2 bolt-on castors, complete (B)

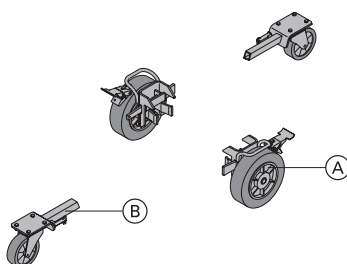

Stacking strap 50

The Stacking strap 50 is the tidy, space-saving way of storing and handling Dokadur panels.

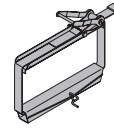

- The Stacking strap 50 is three things in one - base rest profile, lashing strap and edge protection.
- It can also be used in conjunction with the wheel-around Doka stacking pallet (for handling stacks of panels with no need for a crane).
- Dokadur panels are delivered ex-works strapped together with Stacking straps 50. Two Stacking straps 50 are needed per stack of panels.



Dokadur panels 21mm	50 units
Dokadur panels 27mm	40 units

Repropping, concrete technology and striking

When is the best time to strike?

In the building construction field, the load occurring during pouring (i.e. the weight of the uncovered floor) will generally be approx. 50% of the design load of the floor-slab (dead weight + flooring + live load).

This means that the formwork can be struck once the concrete has reached 50% of its 28-day strength. The loading safety of the floor-slab is then equal to that of the finished structure.



Important note:

If the load is not removed from the formwork props at this stage, they will remain loaded with the dead weight of the floor-slab.

When the floor above is concreted, this may lead to a doubling of the load that is being applied to the props.

The props are not designed to cope with such an overload, and the result may be damage to the formwork, the props and the structure.

What does this mean for Doka Xtra?

Thanks to Doka Xtra's integrated "stripping logic", it is possible to start striking the formwork from (min. 20 cm thick) reinforced-concrete slabs at an earlier stage:

- The folding tripods can be removed immediately after pouring.
- As soon as the concrete has attained the properties (in terms of concrete strength, E-modulus) specified for **C12/15¹⁾** concrete as defined by DIN 1045-1 and ÖN B4710-1 (EN 206-1), and provided that there is a minimum reinforcement of 1.2 cm²/m (crosswise), the following formwork components can be removed:
 - intermediate props
 - secondary beams
 - most of the Dokadur panels
 - primary beams

¹⁾ The first figure ("12") refers to the **cylinder compressive strength**, and the second number ("15") to the **cube compressive strength** in **N/mm²**.

For economic reasons (so that the equipment can be re-used as soon as possible), the main props with the Xtra heads should be removed as soon as the concrete strength necessary for removal of all the formwork from the floor-slab has been reached. (Temporary repropping may then be needed).

If it is nevertheless intended to leave these props in place beneath the floor-slab for longer, the load must be taken off them first (at the very latest before the floor above is poured). Failure to do this can lead to overloading of the floor props or even of the structure itself.

Why re-prop after striking the formwork?

Depending on the construction sequence, temporary repropping may be needed to carry **live loads** on the new floor-slab, and/or **concreting-loads** from the next floor to be poured.

Positioning the reshoring props correctly

Reshoring props have the job of spreading loads between the new floor-slab and the floor beneath it. This load distribution will depend on the relationship between the rigidities of these two floor-slabs.

The required numerical relationship between reshoring props and formwork props can be stated for the following two limit cases:

- **only approx. 0.4 reshoring props per formwork prop** where both floor-slabs have similar rigidities
- **only approx. 0.8 reshoring props per formwork prop** where the floor-slab below has a considerably higher rigidity (foundation slab).



Ask an expert!

As a rule, the question of temporary repropping should be referred to the responsible experts, regardless of the information given above. If there is any doubt, particularly where dissimilar floor systems are involved, the decision must be referred to the responsible structural designer.

Strength development in the new concrete

This diagram shows the strength development where different grades of cement are used. The pre-condition here is that there is an average temperature of 20°C in the concrete during the curing period.

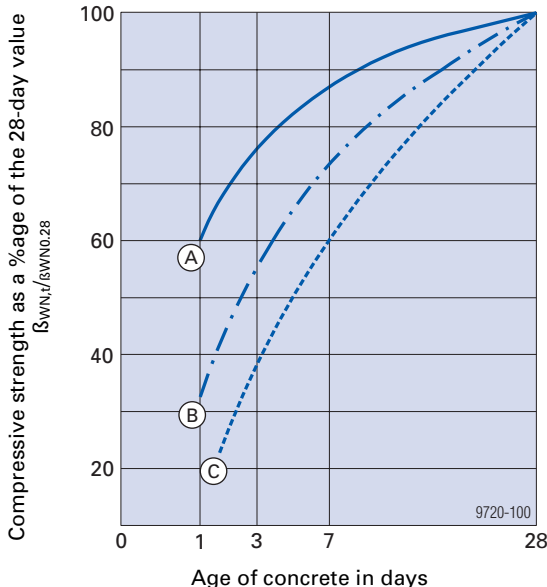

Water/binding-agent (cement) ratio = 0.50

A Z 45 F, PZ 475

B Z 35 F, PZ 375

C Z 35 L (blast-furnace cement with 60% blast-furnace slag)

Deflection of the new concrete

The modulus of elasticity of the concrete has already reached more than 90 % of the 28-day value after only 3 days, regardless of the formulation of the concrete. The increase in the elastic deformation taking place in the new concrete is thus only negligible.

The creep deformation, which only finally ceases after several years, is several times more than the elastic deformation.

However, early striking - e.g. after 3 days instead of 28 - only leads to an increase in the total deformation of less than 5 %.

The part of this deformation accounted for by creep deformation, however, may be anything between 50 % and 100 % of the standard value, due to such variable influences as the strength of the aggregates, and the atmospheric humidity. This means that the total deflection of the floor-slab is practically independent of the time at which the formwork was struck.

Cracks in new concrete

The bonding strength between the reinforcement steel and the concrete develops more rapidly in the new concrete than does its compressive strength. This means that early striking does not have any negative influence upon the size and distribution of cracks on the tension side of reinforced concrete constructions.

Other cracking phenomena caused by e.g. shrinkage, premature striking, impeded deformation etc. can be countered effectively by appropriate curing methods.

Curing of new concrete

New site-placed concrete is exposed to influences which may cause cracking and slow down its strength development:

- premature drying
- over-rapid cooling in the first few days
- excessively low temperatures or frost
- mechanical damage to the surface of the concrete
- etc.

The simplest precaution is to leave the formwork on the concrete surface for longer. As well as the familiar extra curing measures, this measure should be carried out in any case.

Striking the formwork from wide-spanned floor-slabs with support centres of over 7.5m

In the case of thin, wide-spanned concrete floor-slabs (e.g. in multistorey car parks), the following points must be remembered:

When the formwork is removed from beneath these floor-slab spans (i.e. when the load is taken off the props), the props that are still in place are briefly subjected to additional loads. This may lead to overloading, and to the props being damaged.

When planning and designing floor formworks for these very thin concrete floor slabs, it is thus essential to allow for the **loads occurring during formwork removal**, as well as for the usual design loads. Please consult your Doka technician.

 **The basic rule is:**

The formwork should be removed starting from the **middle of the floor slab (i.e. from mid-span)**, and **working towards the edges**.

For wide spans, this procedure **MUST** be followed!

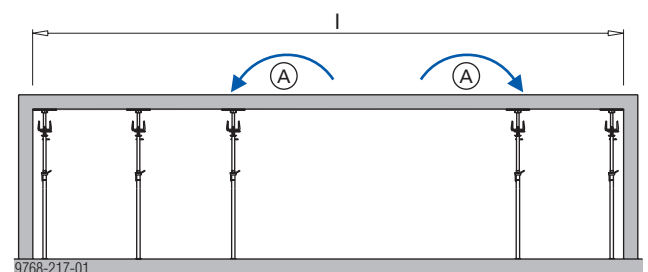

l ... Effective floor-slab spans of 7.50 m and over

A Load redistribution

Doka service offerings

Doka Reconditioning Service

So that your formwork is in "top form" for its next assignment

Inspecting, cleaning and maintaining your Doka Xtra system - the Doka Reconditioning Service will be pleased to take care of all of these tasks for you. Its highly qualified staff and special equipment will soon get your formwork back in top form, quickly and economically.

The advantage for you: You always have formwork that is **ready for use**, and also **extend the service life** of your equipment.

What's more: It is only with well-maintained formwork that you will achieve the desired quality of concrete surface.

In our modern plants, your formwork will be **carefully cleaned** using energy-saving and environmentally sound technology.

Doka customer training

Formwork training pays

Forming operations account for the lion's share of labour costs on concrete construction sites. Modern formwork equipment helps to rationalise operations. By improving the overall construction sequence at the same time, however, further very worthwhile gains in efficiency can be achieved.

This requires not only better equipment, but also greater skill in making optimum use of this equipment. Doka can help here, with its specialist training programme - to help each and every member of the team do his bit towards boosting efficiency and lowering costs.

Doka customer training events also look at the formwork equipment and handling methods that are needed in order to achieve optimum safety - knowledge and awareness which can only enhance workplace safety on the site.

You'll find the Doka training programme well worth looking into.

Your nearest Doka branch will be pleased to tell you more about Doka's various training offerings.

Formwork planning with Tipos

Tipos-Doka helps you to form even more efficiently

Tipos has been developed to assist you in planning the use of your Doka formwork. For wall formwork, floor formwork and platforms, it puts the same tools into your hands that we at Doka use ourselves for formwork planning.



Easy to use, fast and accurate results

The easy-to-use interface makes for very fast working. From when you input your layout (with the "Schal-Igel"® on-screen assistant), all the way through to when you manually put the finishing touches to the formwork solution the program gives you. All this saves time - yours.

The program contains a large number of templates from formwork practice, so you can be sure of always getting the optimum technical and economical solution to your formwork task. This makes for greater operational reliability, and cuts costs.

You can get to work right away with the piece-lists, plans, views, sections and perspective drawings that the program gives you. Operational reliability is also enhanced by the high level of detail of the plans.

Always the right quantities of formwork and accessories





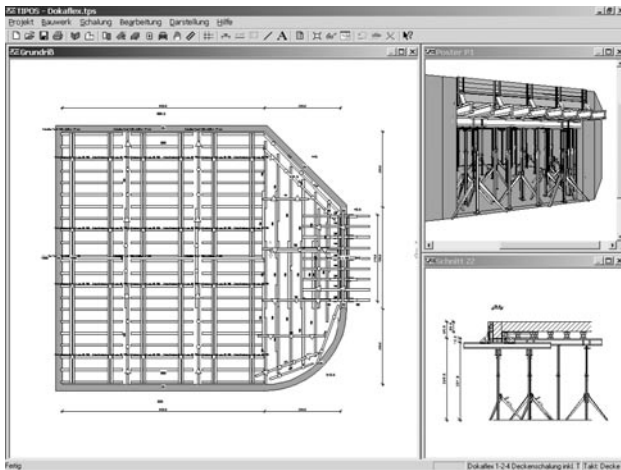

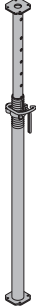

Stücklistenbearbeitung									
Herst	Artikelnr	Bezeichnung	Pr./Stk	Baus	Bauh	Lief	Man	Sum	
DOKA	586174000	Absenkkopf H20	45.50	0	0	24	0	24	
DOKA	586149000	Balkenaufsatz 60 cm	32.50	0	0	5	0	5	
DOKA	586148000	Balkenzwinde 20	83.00	0	0	10	0	10	
DOKA	586086000	Doka-Deckenstütze Eurex 20 250	72.50	0	0	55	0	55	
DOKA	586092000	Doka-Deckenstütze Eurex 30 250	79.00	0	0	24	0	24	
DOKA	186007000	Doka-Schalungsplatte 3-SO 21 mm 100/50 cm	13.48	0	0	16	0	16	
DOKA	186008000	Doka-Schalungsplatte 3-SO 21 mm 150/50 cm	20.21	0	0	3	0	3	
DOKA	186009000	Doka-Schalungsplatte 3-SO 21 mm 200/50 cm	26.95	0	0	2	0	2	
DOKA	186011000	Doka-Schalungsplatte 3-SO 21 mm 250/50 cm	33.69	0	0	22	0	22	
DOKA	189924000	Doka-Schalungsträger H 20 P 1.80 m	29.35	0	0	2	0	2	
DOKA	189907000	Doka-Schalungsträger H 20 P 2.45 m	39.95	0	0	1	0	1	
DOKA	189910000	Doka-Schalungsträger H 20 P 2.85 m	43.20	0	0	34	0	34	
DOKA	189917000	Doka-Schalungsträger H 20 P 3.90 m	63.55	0	0	13	0	13	
DOKA	186082000	Dokadur Paneel 21 150/50 cm	41.25	0	0	12	0	12	
DOKA	586055000	Dokaflex-Tisch 2,50 x 5,00 m - 27 mm	Auf Anfr...	0	0	6	0	6	
DOKA	582528000	Federbolzen 16 mm verzinkt	4.95	0	0	55	0	55	
DOKA	586176000	Haltekopf H20	8.75	0	0	31	0	31	
DOKA	586155000	Stützbein	101.50	0	0	24	0	24	
DOKA	996000101	bauseitige Kanthölzer	0.00	0	0	12	0	12	

You can import the automatically generated piece-lists into many other programs for further processing. Formwork components and accessories that have to be organised at short notice, or replaced by improvisation, are the ones that cost the most. This is why Tipos-Doka offers complete piece-lists that leave no room for improvisation. Planning with Tipos-Doka eliminates costs before they have a chance to even arise. And your depot can make the best possible use of its stocks.

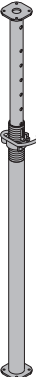

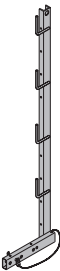
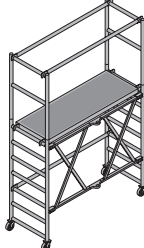
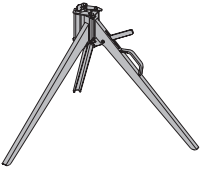
Formwork drawings really can be as clear and detailed as this! Both for the layout and for spatial representations, Tipos-Doka sets an impressive new standard of visual presentation.

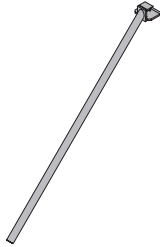

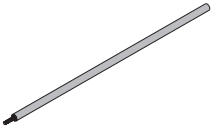
	[kg]	Article n°		[kg]	Article n°	
Doka floor prop Eurex 20 250 Height: 148 - 250 cm Doka floor prop Eurex 20 300 Height: 172 - 300 cm Doka floor prop Eurex 20 350 Height: 197 - 350 cm Doka floor prop Eurex 20 400 Height: 223 - 400 cm Doka floor prop Eurex 20 550 Height: 297 - 550 cm Doka-Deckenstütze Eurex 20	12.9	586086000	 <p>Galvanised Permissible load: 20 kN at any telescoping length to EN 1065</p>	Spring locked connecting pin 16mm Federbolzen 16mm  <p>Galvanised Length: 15 cm Packed in units of 100</p>	0.25	582528000
Doka floor prop Eurex 30 250 Height: 148 - 250 cm Doka floor prop Eurex 30 300 Height: 172 - 300 cm Doka floor prop Eurex 30 350 Height: 197 - 350 cm Doka floor prop Eurex 30 400 Height: 223 - 400 cm Doka floor prop Eurex 30 450 Height: 248 - 450 cm Doka-Deckenstütze Eurex 30	14.8	586092000	 <p>Galvanised Permissible load: 30 kN at any telescoping length to EN 1065</p>	Handrail clamp S Schutzgeländerzwinge S  <p>Galvanised Height: 123 - 171 cm</p>	11.5	580470000
				Handrail post T 1.80m Einschubgeländer T 1,80m  <p>Galvanised</p>	17.7	584373000
				Wheel-around scaffold DF Mobilgerüst DF  <p>Aluminium Length: 195 cm Width: 80 cm Height: 290 cm Permissible load: 150 kg/m²</p>	44.0	586157000
Removable folding tripod Stützbein  <p>Galvanised Height: 100 cm</p>	15.6	586155000	Alu beam fork H20 Alu-Trägergabel H20  <p>Aluminium Powder-coated yellow Length: 176 cm</p>	2.4	586182000	
Doka Xtra head Doka Xtra-Kopf  <p>Galvanised Height: 69 cm</p>	9.7	586108000	Stripping lever DF 1.20m Ausschalhebel DF 1,20m  <p>Powder-coated yellow</p>	2.7	586158000	
Supporting head H20 DF Haltekopf H20 DF  <p>Galvanised Length: 19 cm Width: 11 cm Height: 8 cm</p>	0.77	586179000	Lever extension DF 1.20m Hebelverlängerung DF 1,20m  <p>Powder-coated yellow</p>	2.0	586159000	

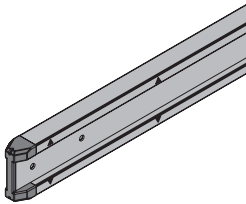
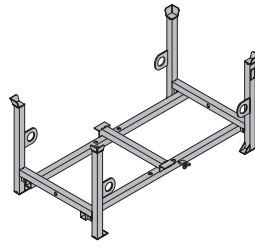
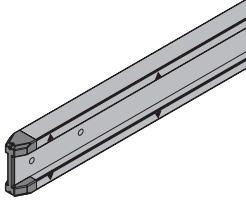
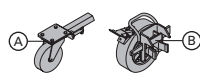
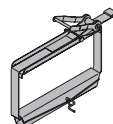
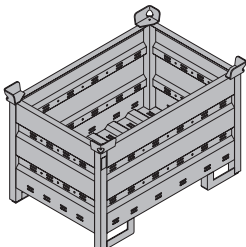
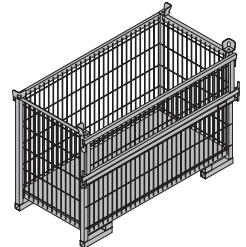
	[kg]	Article n°		[kg]	Article n°
Doka beam H20 top N 2.65m Doka-Träger H20 top N 2,65m  <p>Varnished yellow Permissible bending moment: 5.0 kNm Permissible shear force: 11.0 kN Approval by Institute of Building Technology, Berlin. Values applicable only when formwork beams are upright. Permissible shearing forces are lower by several orders of magnitude if formwork beams are horizontal.</p>	13.7	189013000	Doka stacking pallet 1,55x0,85m Doka-Stapelpalette 1,55x0,85m  <p>Galvanised Length: 154 cm Width: 83 cm Height: 77 cm Max. load: 1100 kg (11 kN) Follow the directions in the "Operating Instructions"! CE</p>	42.0	586151000
Doka beam H20 top P 2.65m Doka-Träger H20 top P 2,65m  <p>Varnished yellow Permissible bending moment: 5.0 kNm Permissible shear force: 11.0 kN Approval by Institute of Building Technology, Berlin. Values applicable only when formwork beams are upright. Permissible shearing forces are lower by several orders of magnitude if formwork beams are horizontal.</p>	13.9	189703000	Bolt-on castor set Anklemm-Radsatz consisting of: (A) Bolt-on castors, complete 2 pcs. Height: 23 cm (B) Heavy-duty wheels, complete 2 pcs. Height: 32 cm  <p>Painted blue Max. load: 1100 kg (11 kN) Fit onto the Doka stacking pallet and the Doka accessory box.</p>	33.5	586154000
Dokadur panel 21 200/50cm Dokadur panel 21 250/50cm Dokadur-Paneel 21 <p>High-grade floor-forming panels, 3-ply, 21 mm, with impact-resistant plastic surround. For clean concrete faces with plain surface appearance. Also available for rental.</p>	11.0 13.8	186083000 186081000	Stacking strap 50 Stapelgurt 50  <p>Powder-coated, blue Perm. strapping force: 40 kN</p>	3.3	586156000
Dokadur panel 27 200/50cm Dokadur panel 27 250/50cm Dokadur-Paneel 27 <p>High-grade floor-forming panels, 3-ply, 27 mm, with impact-resistant plastic surround. For clean concrete faces with plain surface appearance. Also available for rental.</p>	13.5 16.9	187170000 187168000			
Doka multi-trip transport box 1.20x0.80m Doka-Mehrwegcontainer 1,20x0,80m  <p>Galvanised Height: 78 cm Max. load: 1500 kg (15 kN) Follow the directions in the "Operating Instructions"! CE</p>	75.0	583011000			
Doka skeleton transport box 1.70x0.80m Doka-Gitterbox 1,70x0,80m  <p>Galvanised Height: 113 cm Max. load: 700 kg (7 kN) Follow the directions in the "Operating Instructions"! CE</p>	87.0	583012000			

Doka Xtra Floor System – the manhandled system with integrated "stripping logic"

Just three - perfectly co-ordinated - system components are all it takes to optimise your site logistics. The Doka Xtra head gives you the option of striking most of the component parts ahead of time. This speeds up the workflow on the site, as well as reducing commissioning quantities.

With Doka Xtra, the formwork equipment is subjected to less wear-and-tear, and the operational sequences are made even more efficient.

Doka Xtra is available for rental, leasing or purchase.

At any of the Doka branches in your region.

Why not give us a call?



The Doka Group's central plant at Amstetten, Austria

Certified to
ISO 9001

Doka international

**Österreichische Doka
Schalungstechnik GmbH**

Reichsstrasse 23, A 3300 Amstetten, Austria
Tel.: +43 (0)7472 605-0, Fax: +43 (0)7472 64430
E-Mail: Oest.Doka@doka.com
Internet: www.doka.com

Brazil
Doka Brasil
Fórmass para Concreto Ltda.
Rua Guilherme Lino dos Santos, 800
Jardim Flôr do Campo -
Guarulhos/SP CEP 07.190-010
Telephone: (011) 6404-3500
Telefax: (011) 6404-5700

Egypt
Al-Othman Trading Est.
P.O.Box 5643
Salah Salem Street
Heliopolis, West Cairo
Telephone: (2) 404 9137
Telefax: (2) 403 6375

Finland
Doka Finland Oy
Selintie 542
FIN 03320 Selki
Telephone: (09) 22 42 64 0
Telefax: (09) 22 42 64 20

France
Doka France SAS
3, chemin des Iles, Z.I.
F 78610 Le Perray en Yvelines
Telephone: 01 34 84 27 27
Telefax: 01 34 84 27 00

Greece
Doka Hellas
Kalouptekhniki Technologiki A.E.
Agiou Athanasiou 5
GR 153 51 Pallini / Attiki
Telephone: 210 6669211
Telefax: 210 6032614

Ireland
Doka Ireland Formwork Techn. Ltd.
Monasterboice, Drogheda
County Louth
Telephone: (041) 686 1620
Telefax: (041) 686 1525

Italy
Doka Italia S.p.A.
Strada Provinciale Cerca, 23
I-20060 Colturano MI
Telephone: 02 98 27 6.1
Telefax: 02 98 23 75 77

Korea
Kumkang Doka Co. Ltd.
12F, Kangnam Bldg
1321-1 Seocho-Dong, Seocho-Gu
SEOUL 137-857
Telephone: (0)2 562-3030
Telefax: (0) 2 565-4466

Kuwait
Doka Kuwait
Div. of Riham Gen. Trad.& Cont. Co.
P.O. Box 2217 Salmiyah
22023 Kuwait
Telephone: 482 24 62
Telefax: 482 24 72

Lebanon
**Österreichische Doka
Schalungstechnik GmbH**
Doka Branch Lebanon
Sodeco Square, Block C / 9th floor
Beirut/Lebanon
Telephone: (01) 61 25 69
Telefax: (01) 61 25 69

Norway
Doka Norge AS
Heggstadmoen 4
N 7080 Heimdal
Telephone: 72 89 38 10
Telefax: 72 89 38 11

Portugal
Doka Portugal Cofragens Lda.
Zona Industrial da Brunheira
Sintra Business Park
Edificio 1, 1º M
P 2710-089 Sintra
Telephone: 21 911 26 60
Telefax: 21 911 20 11

Saudi Arabia
Doka Formwork Technology
Div. of Mahmoud Othman Est.
P.O. Box 7620
Jeddah 21472
Telephone: (02) 669 10 08
Telefax: (02) 664 86 25

Spain
Doka España Encofrados, S.A.
Julio Palacios, 20 - 22
E 28914 Leganés - Madrid
Telephone: 91 685 75 00
Telefax: 91 685 75 01

Sweden
Doka Sverige AB
Kurösvägen 20
S 451 55 Uddevalla
Telephone: (0522) 65 66 30
Telefax: (0522) 65 66 39

Singapore
DFS Technology Pte. Ltd.
No. 25 Senoko Drive
Singapore 758212
Telephone: 6747 3890
Telefax: 6747 9770

Taiwan
DEC Engineering Corp.
7 Fl., No.123, Sec.4, Pa-Te Rd.
Taipei, Taiwan, R.O.C.
Telephone: (2) 27 53 42 61
Telefax: (2) 27 53 33 38

Turkey
Doka Kalip-Iskele
Sanayi ve Ticaret A.S.
Baris Mahallesi, Dr.Zeki Acar Cad.10
TR 41400 Gebze, Kocaeli
Telephone: (0262) 642 19 62
Telefax: (0262) 642 19 63

United Arab Emirates
Doka Gulf FZE
P.O. Box 61407
Jebel Ali Free Zone, Dubai
Telephone: 4 881 8096
Telefax: 4 881 8097

United Kingdom
Doka UK
Formwork Technologies Ltd
Monchelsea Farm, Heath Road
Boughton Monchelsea
Maidstone, Kent, ME17 4JD
Telephone: (01622) 74 90 50
Telefax: (01622) 74 90 33

Other subsidiaries and representatives:

Australia
Belgium
Bulgaria
China
Croatia
Czech Republic
Denmark
Estonia
Germany
Guatemala
Hungary
Iceland
India
Indonesia
Iran
Israel
Japan
Latvia
Lithuania
Libya
Malaysia
Mexico
Netherlands
New Zealand
Poland
Qatar
Romania
Russia
Serbia and Montenegro
Slovakia
Slovenia
South Africa
Switzerland
Thailand
Ukraine
USA

doka
The Formwork Experts