

# Informatika alapjai 2

# Műszaki ábrázolás

**RENDEZETT VETÜLETEK**

# A vetületek általános jellemzése

# A vetületek fogalma

A vetület a tárgy képe — adott méretarányban  
— a vetítési szabályok szerint

## A vetületek fajtái

**Nézet:** a tárgy látható felületeinek, éleinek vetülete

**Metszet:** a metszősíkkal képzeletben elvágott tárgy felülete

# **A rendezett vetületek származtatása**

# „Dobozt” alkotó képsíkok felvétele

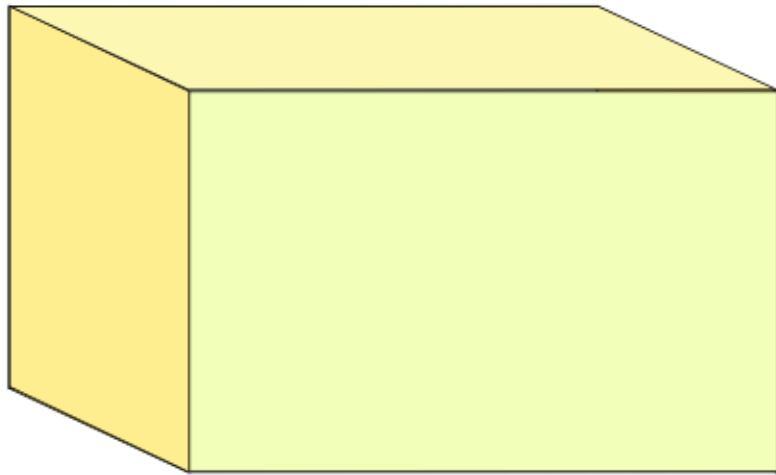

# Az alkatrész (képzeletbeli) elhelyezése a „dobozban”

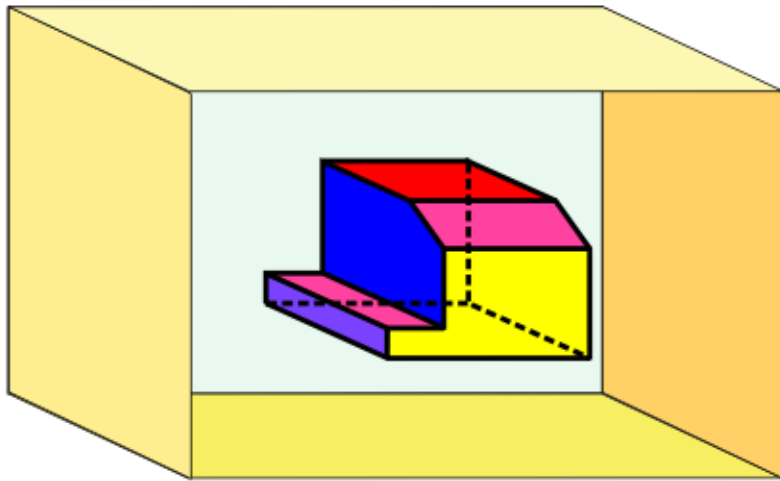



# Vetítés előről→előlnézet

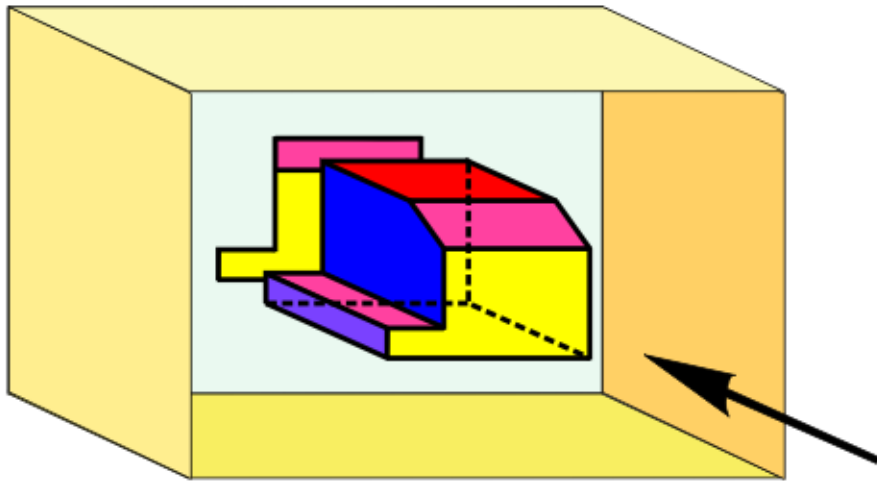

# Vetítés előről→előlnézet

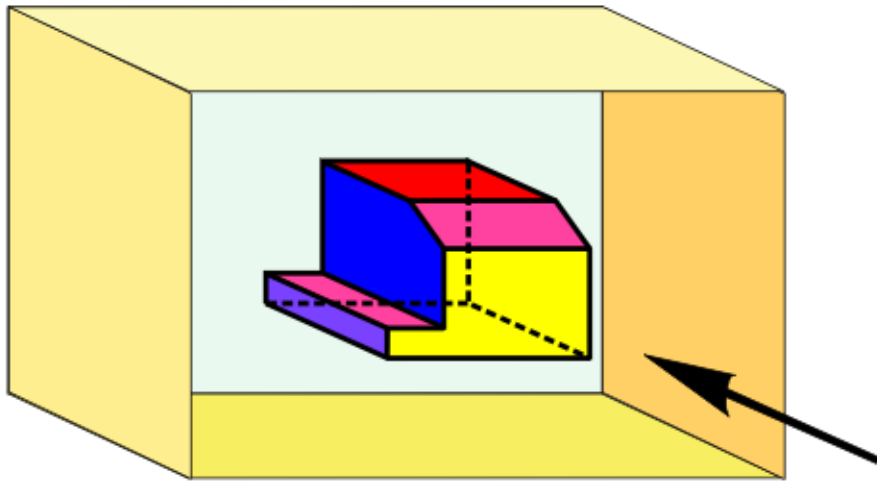

# Vetítés felülről→felülnézet

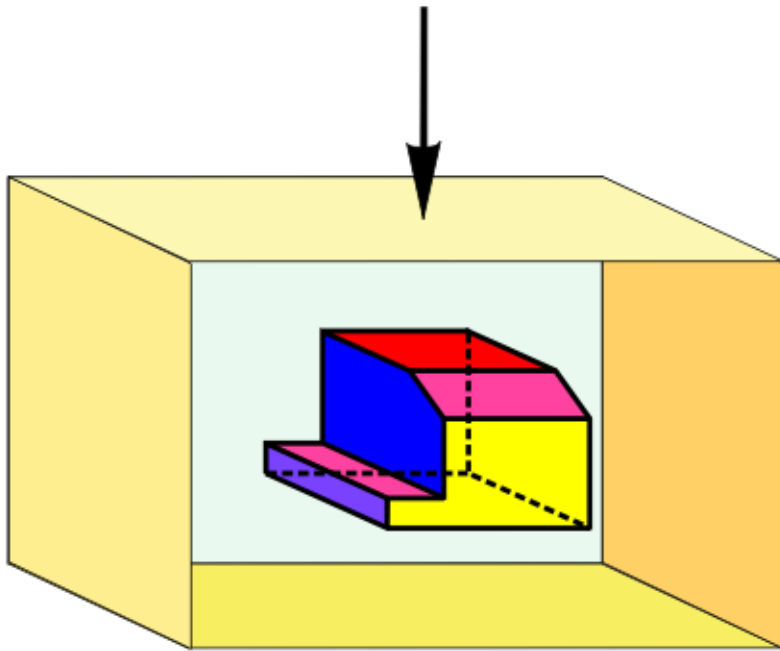

# Vetítés felülről→felülnézet

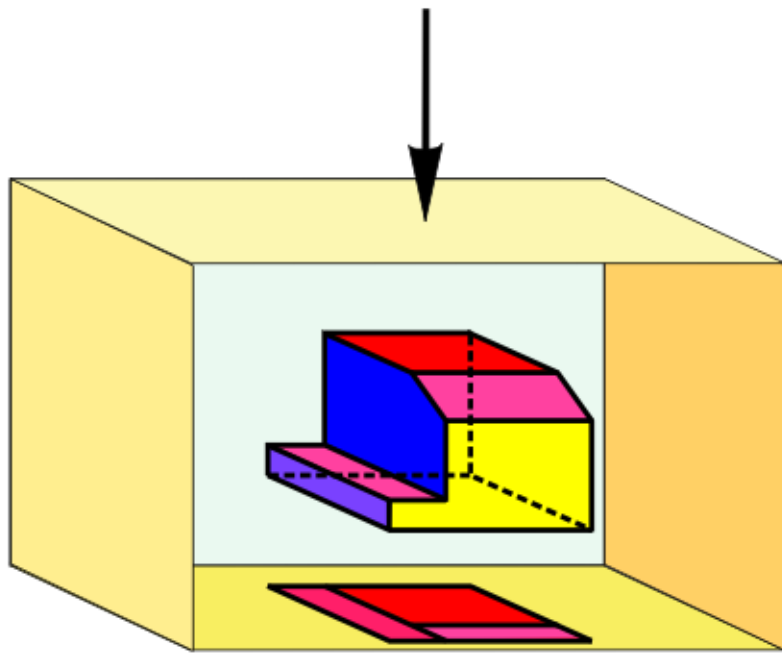

# Vetítés balról→balnézet

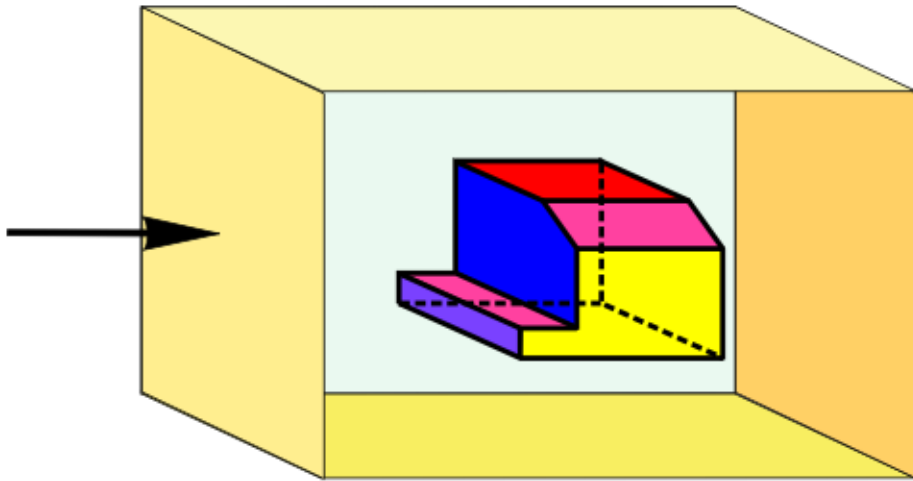

# Vetítés balról→balnézet

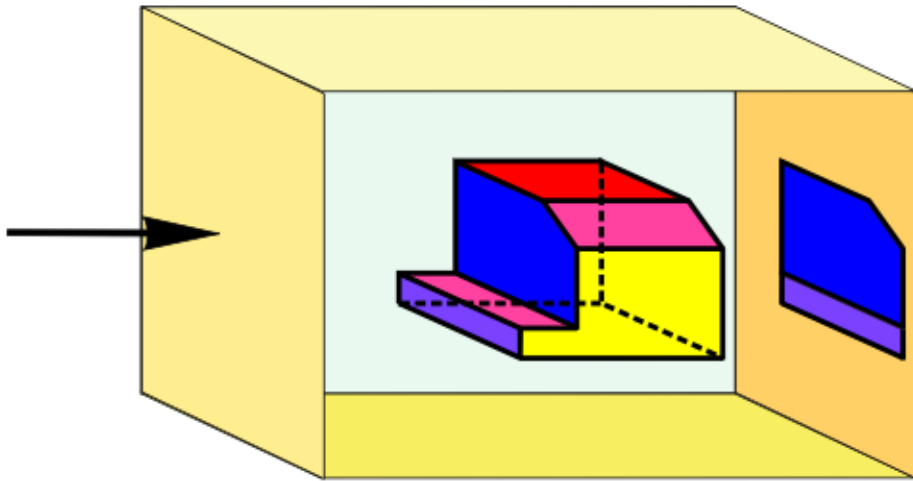

# Vetítés jobbról→jobb nézet

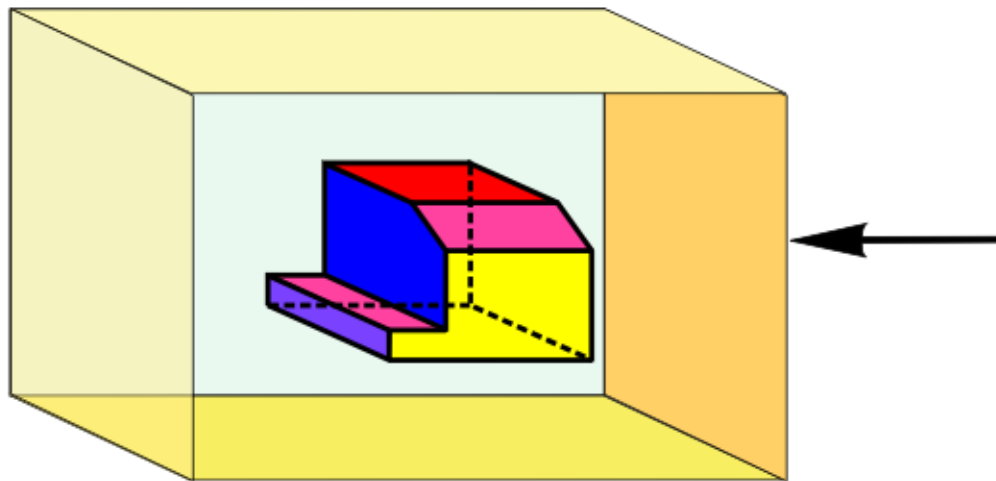

# Vetítés jobbról→jobb nézet

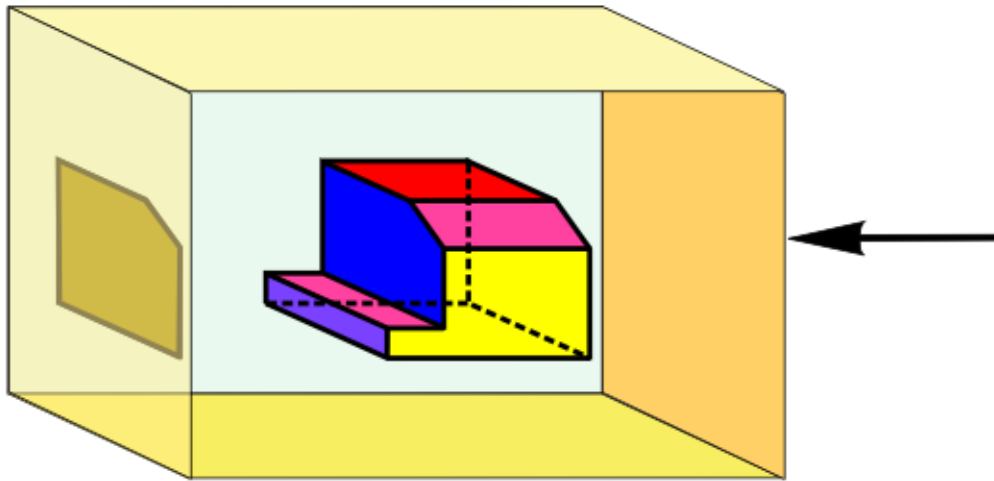



# Vetítés alulról→alulnézet

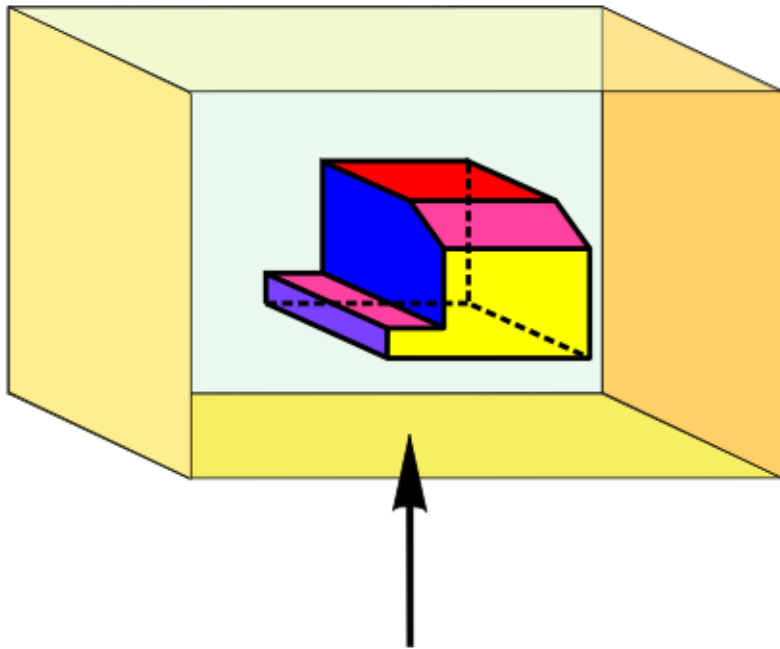

# Vetítés alulról→alulnézet

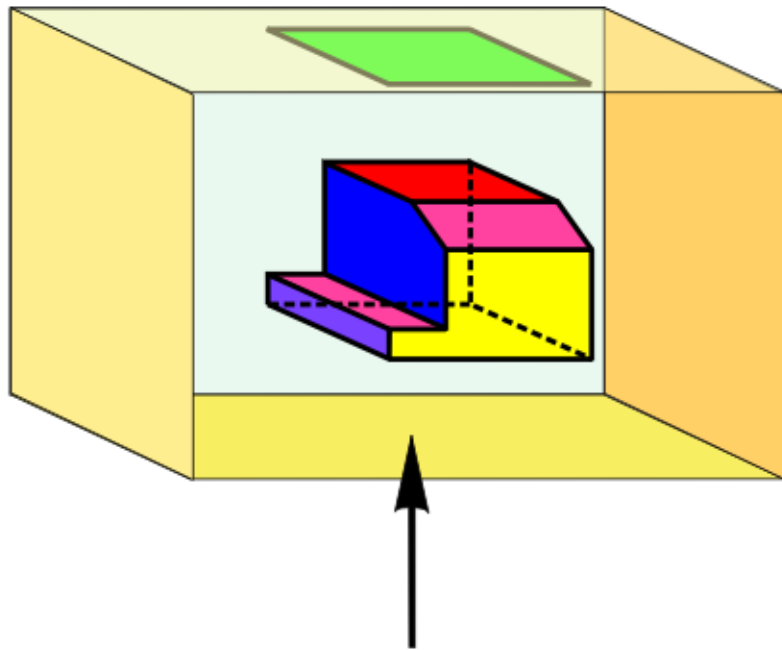

# Vetítés hátról→hátnézet

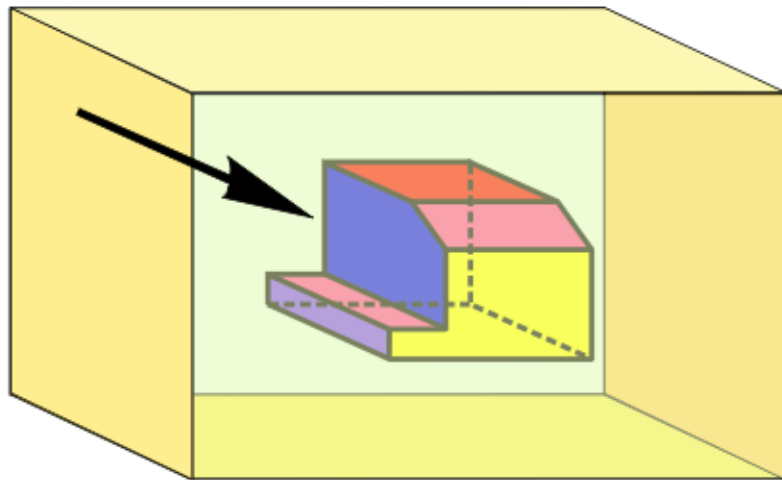

# Vetítés hátulról→hátnézet

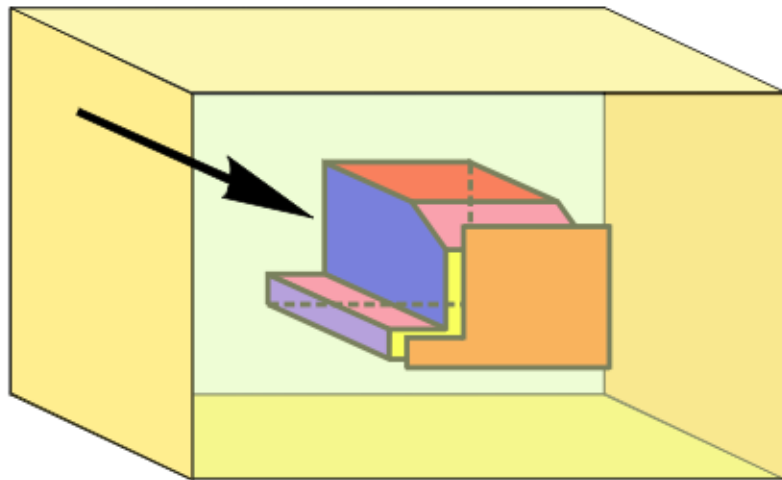

# A „doboz” oldalai a rajta kialakult „fényképekkel”

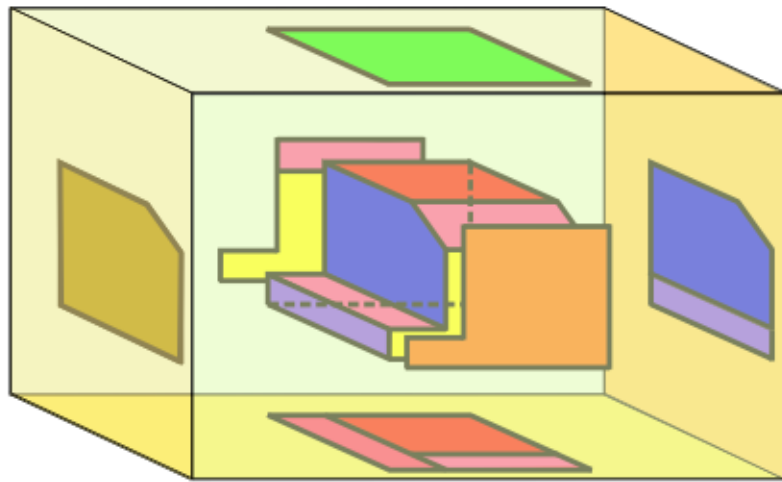

# Az alkatrész (képzeltbeli) eltávolítása a dobozból

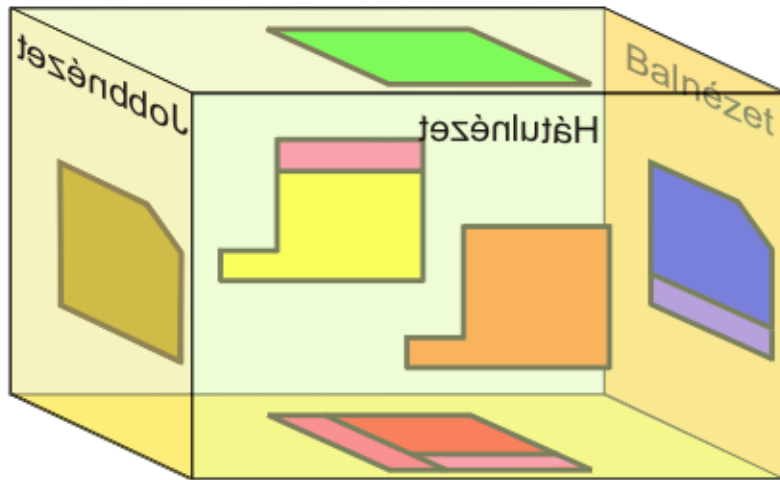

# A „doboz” kiterítése

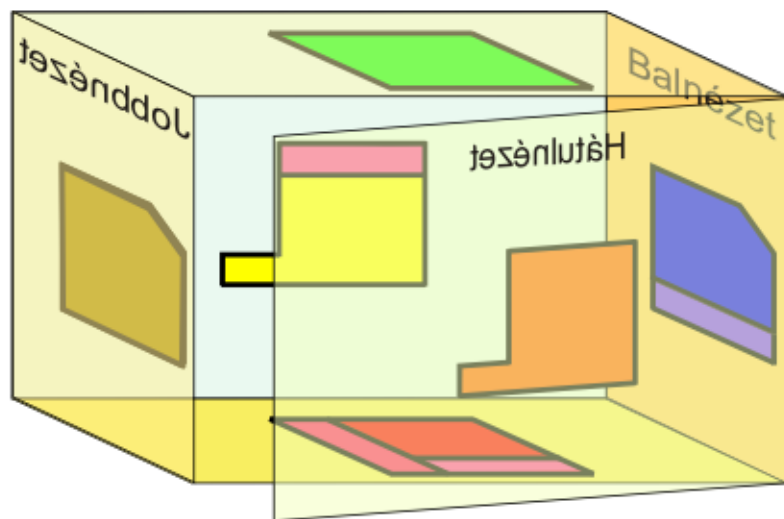

# A „doboz” kiterítése

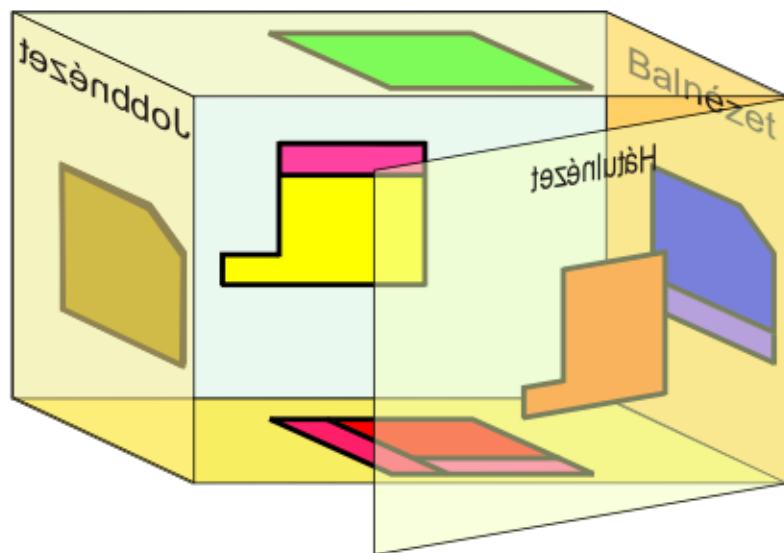



# A „doboz” kiterítése

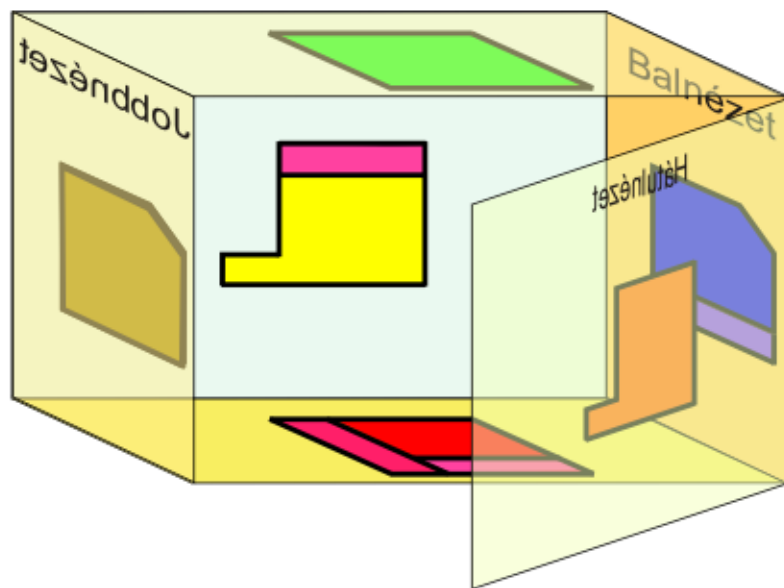

# A „doboz” kiterítése

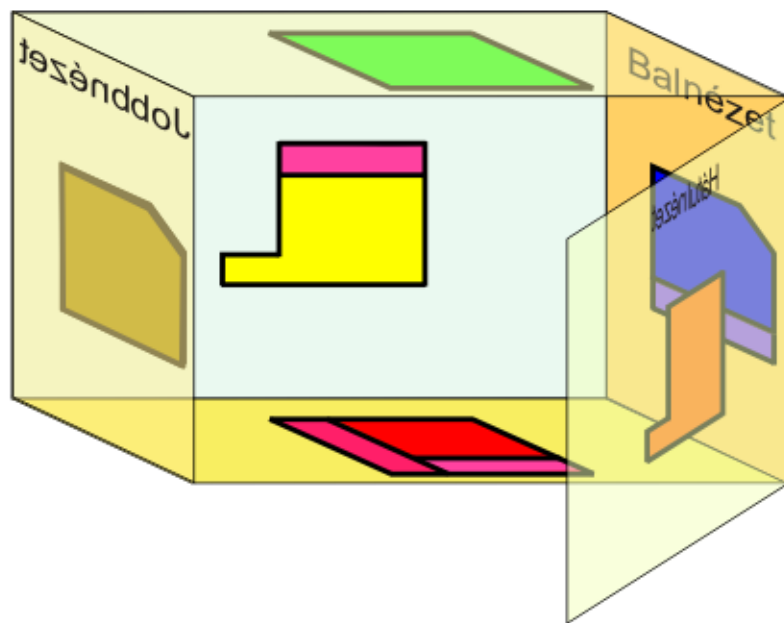

# A „doboz” kiterítése

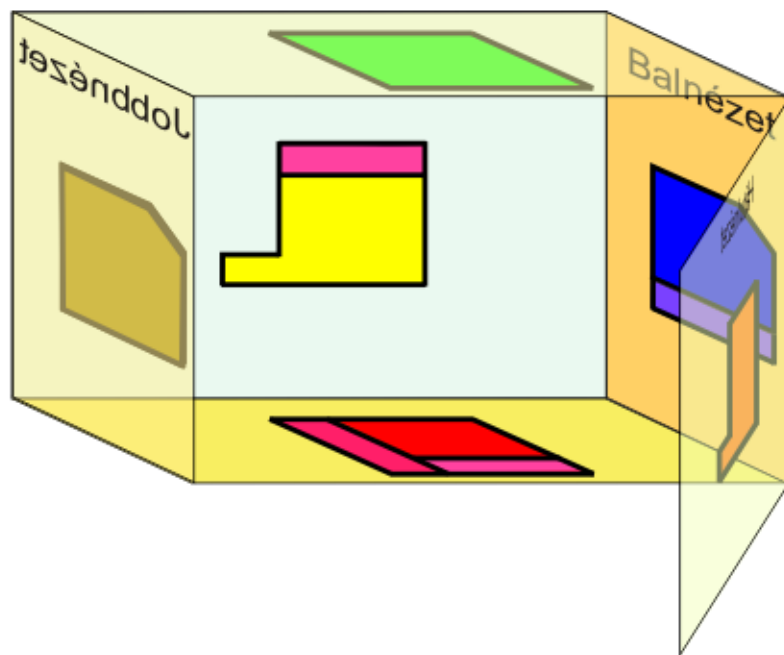

# A „doboz” kiterítése

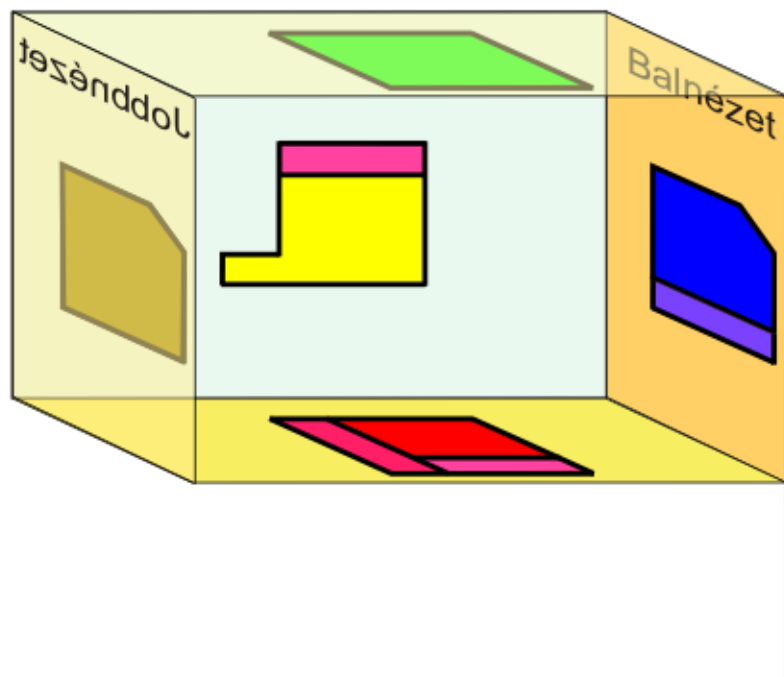

# A „doboz” kiterítése

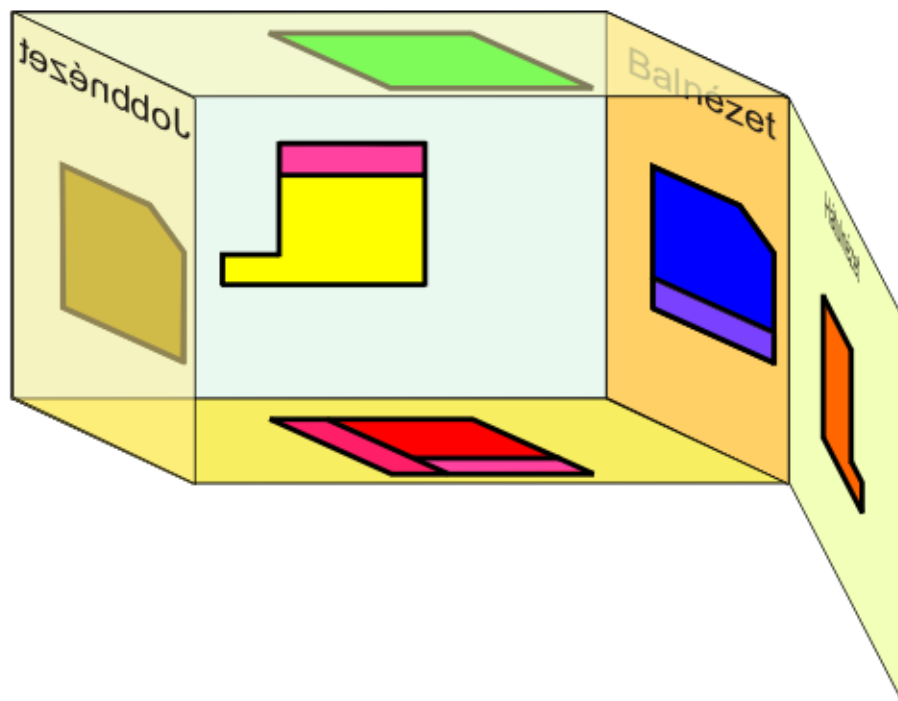

# A „doboz” kiterítése

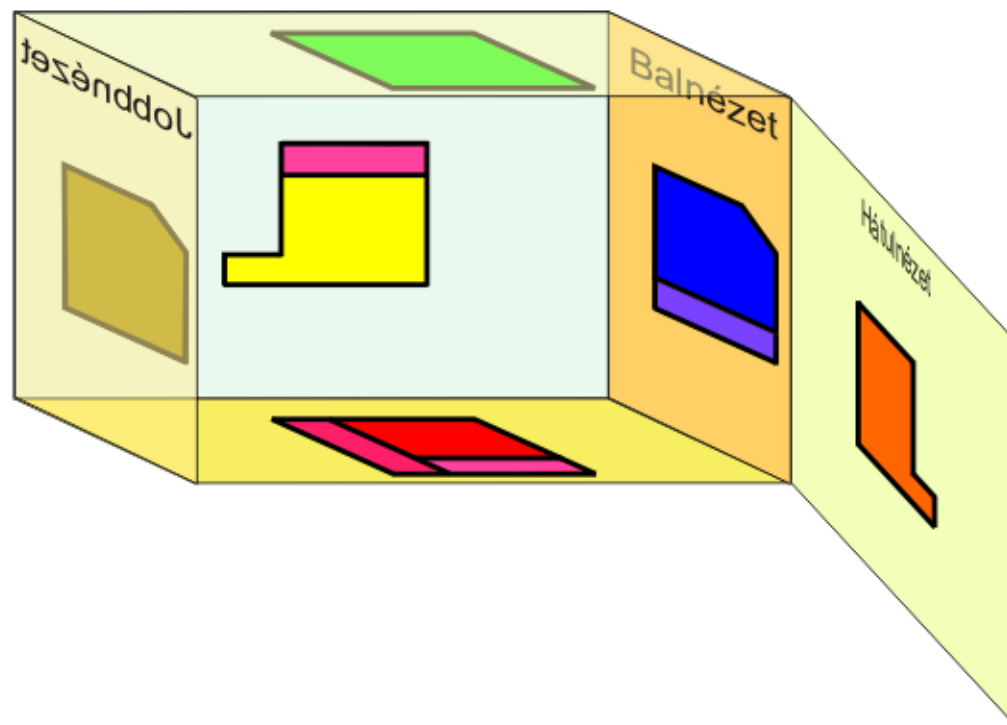

# A „doboz” kiterítése

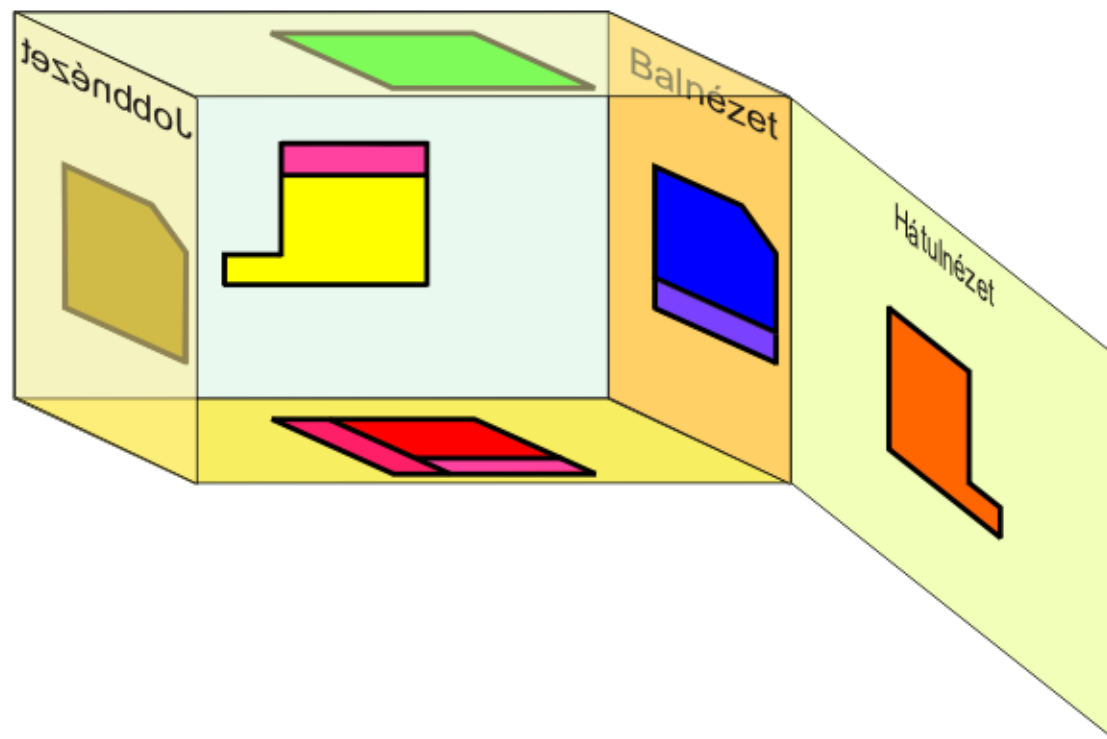

# A „doboz” kiterítése

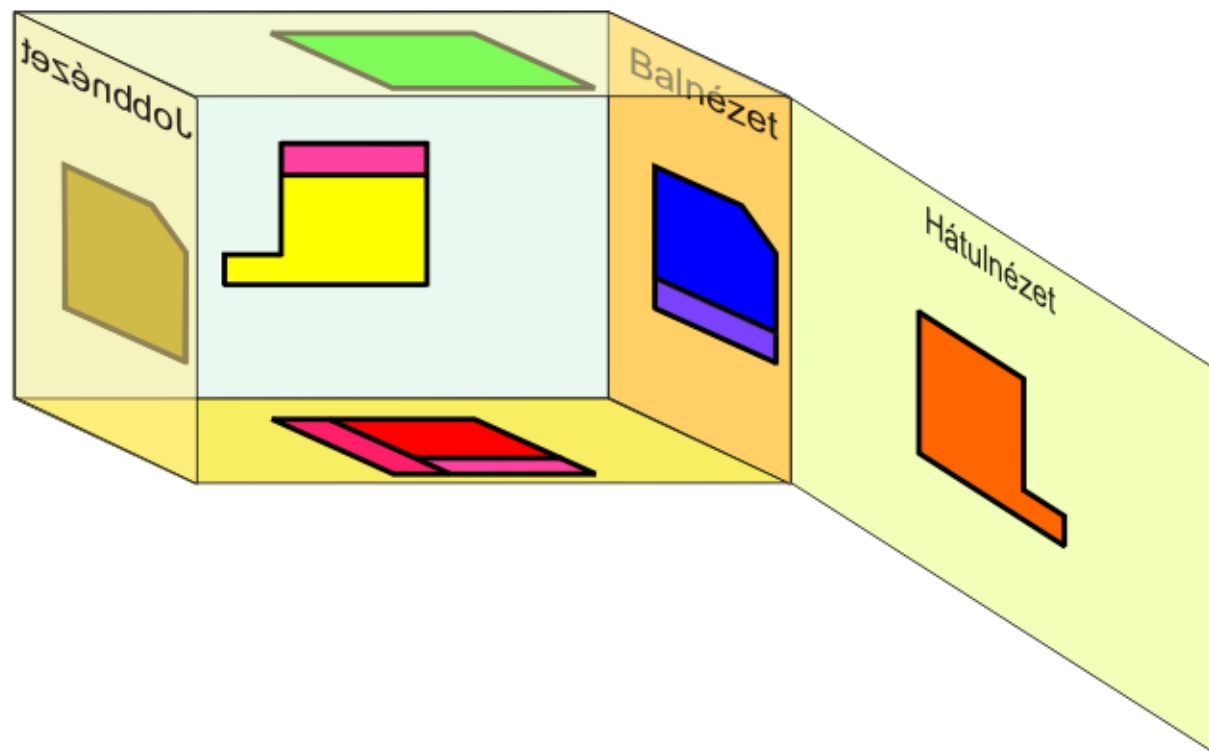



# A „doboz” kiterítése

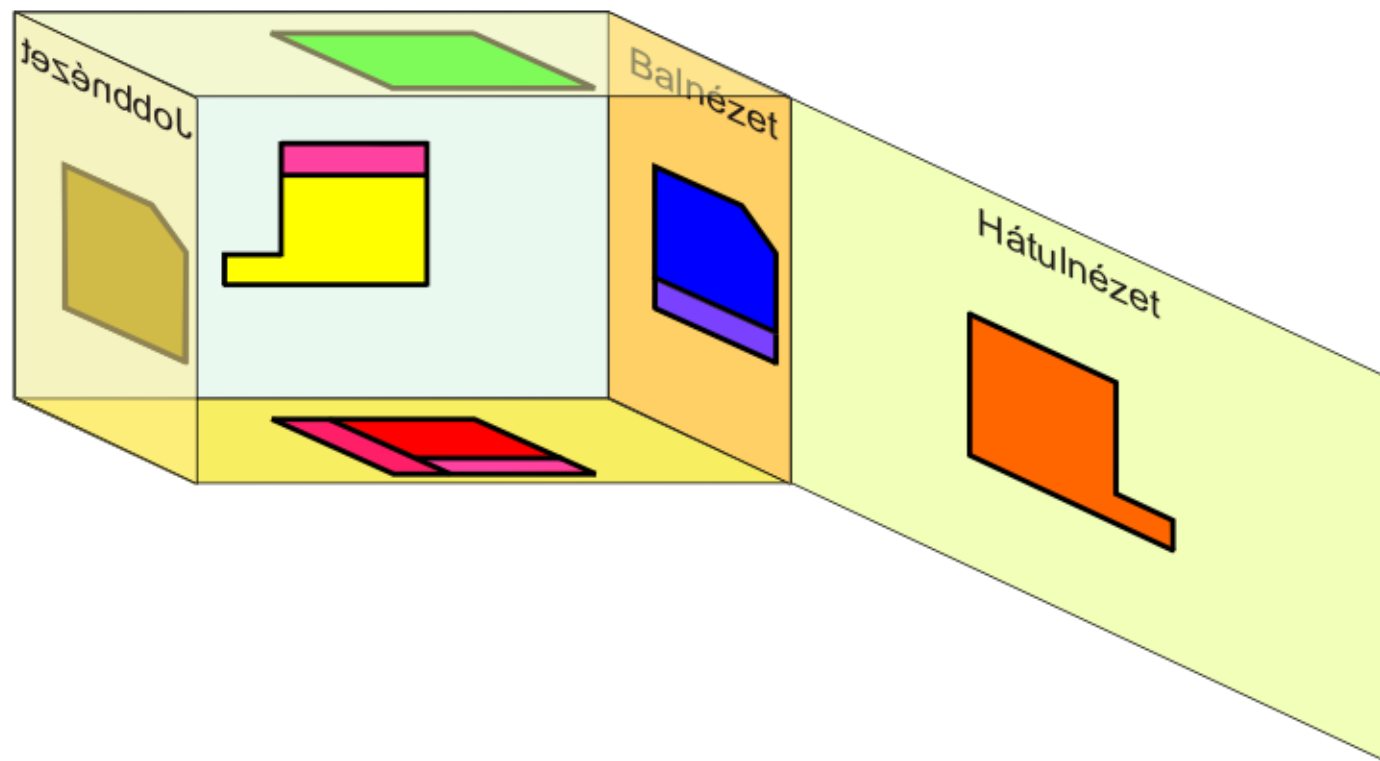

# A „doboz” kiterítése

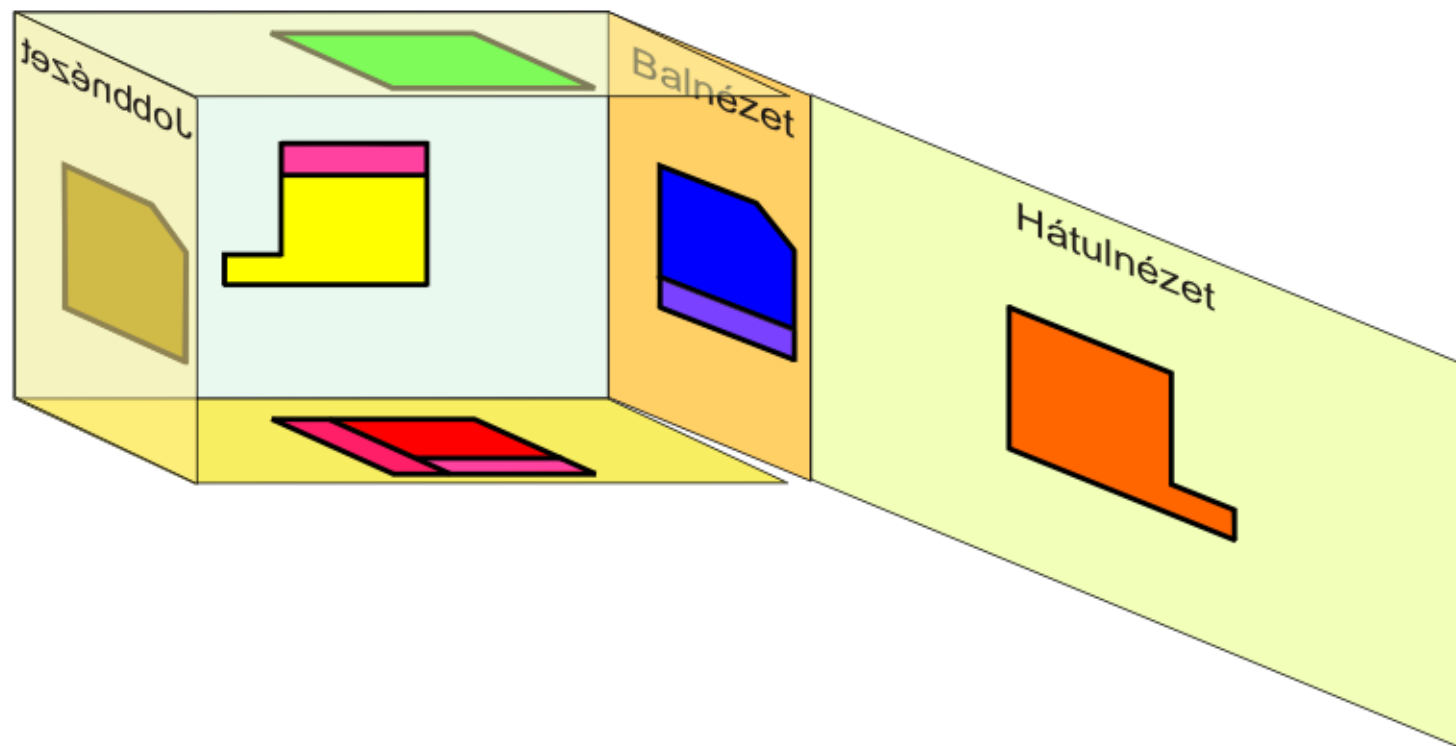

# A „doboz” kiterítése

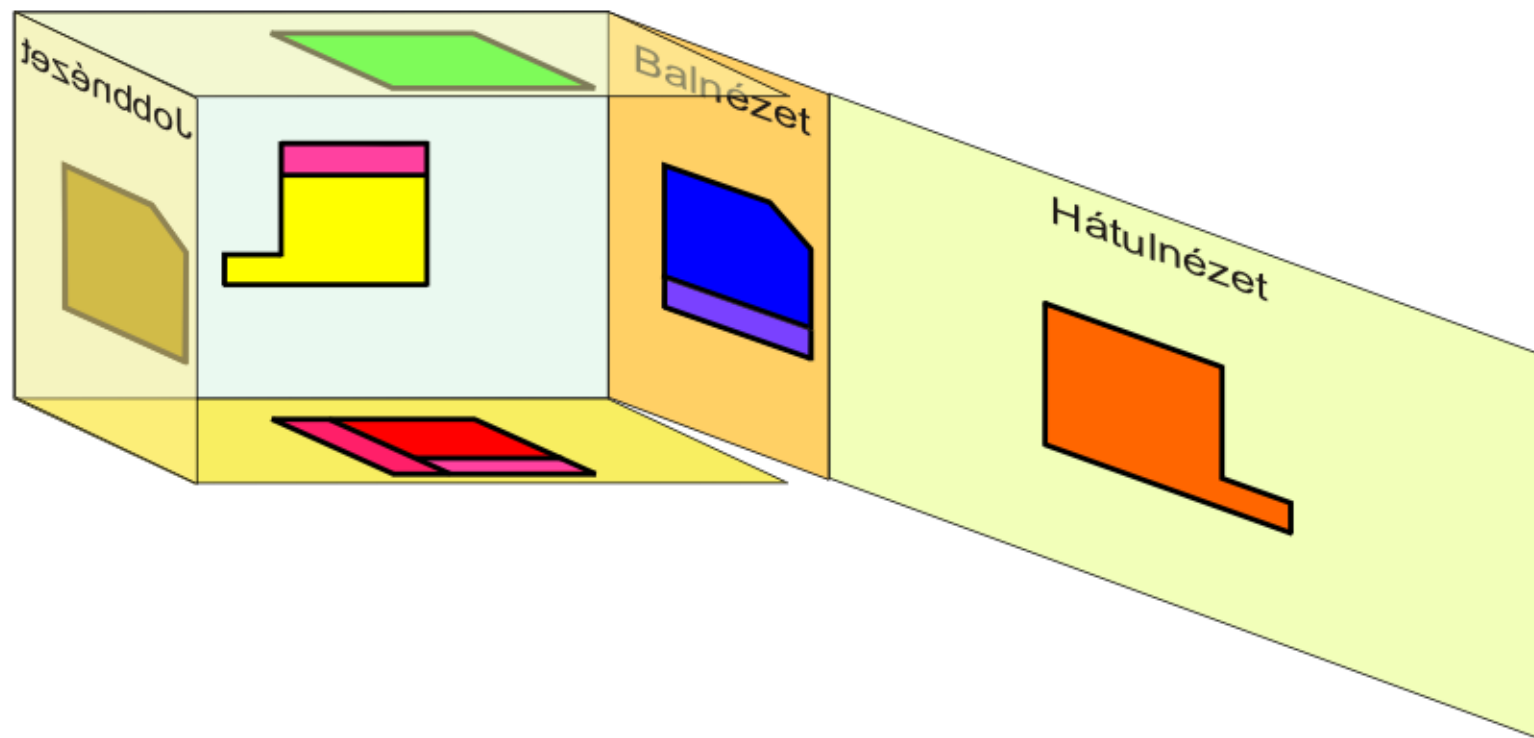

# A „doboz” kiterítése

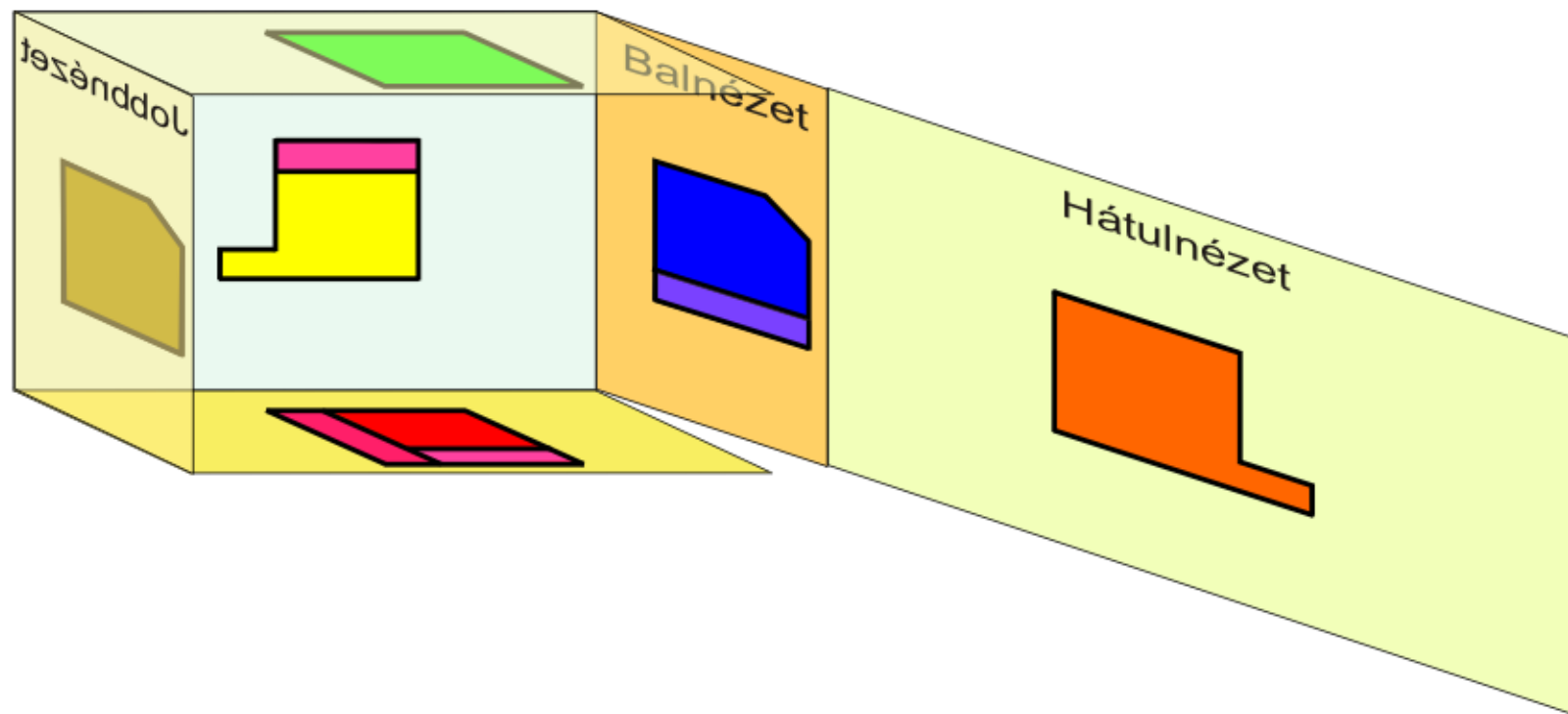

# A „doboz” kiterítése

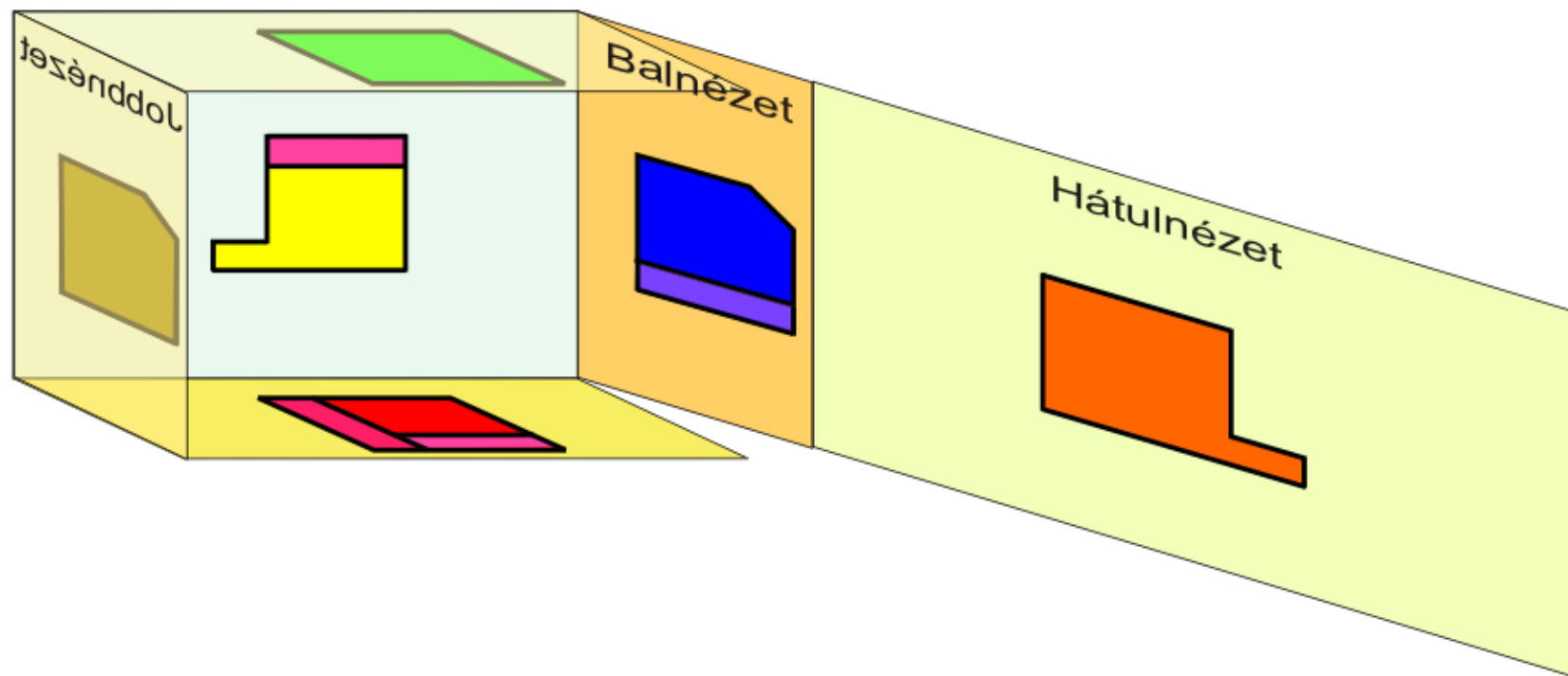

# A „doboz” kiterítése

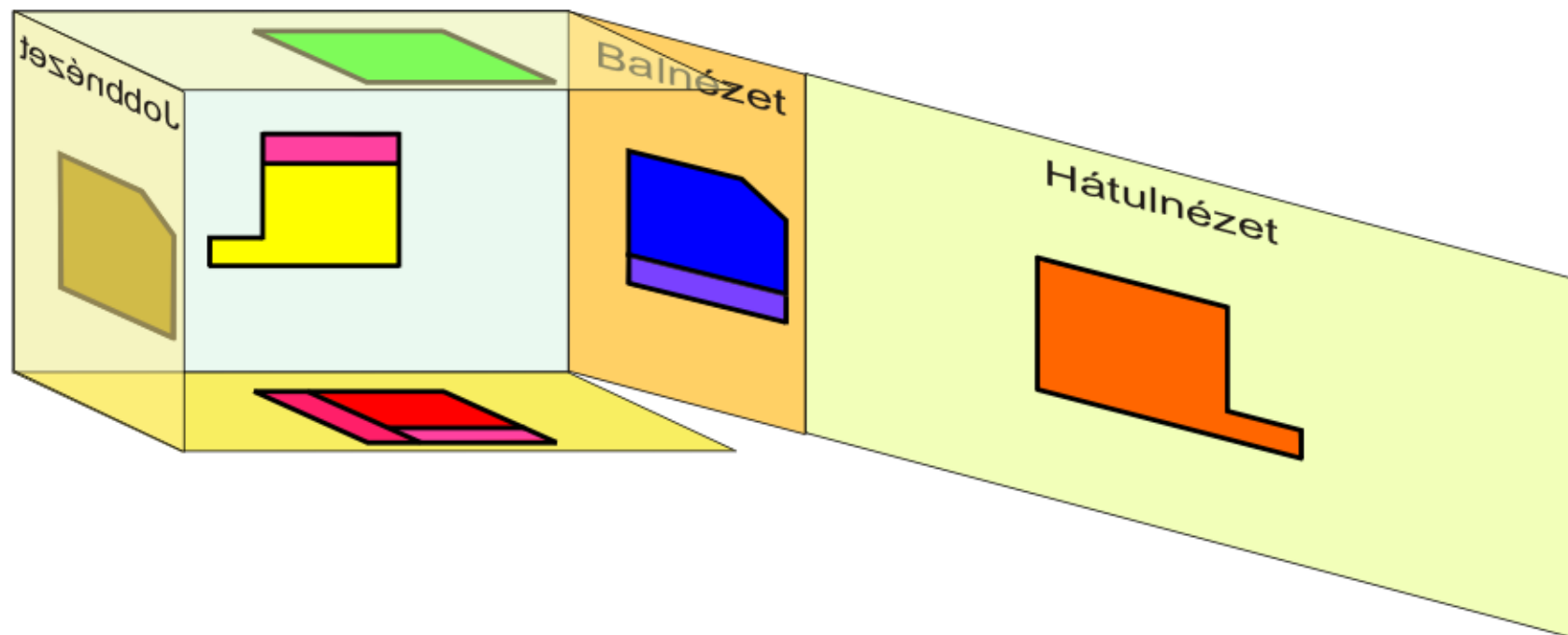

# A „doboz” kiterítése

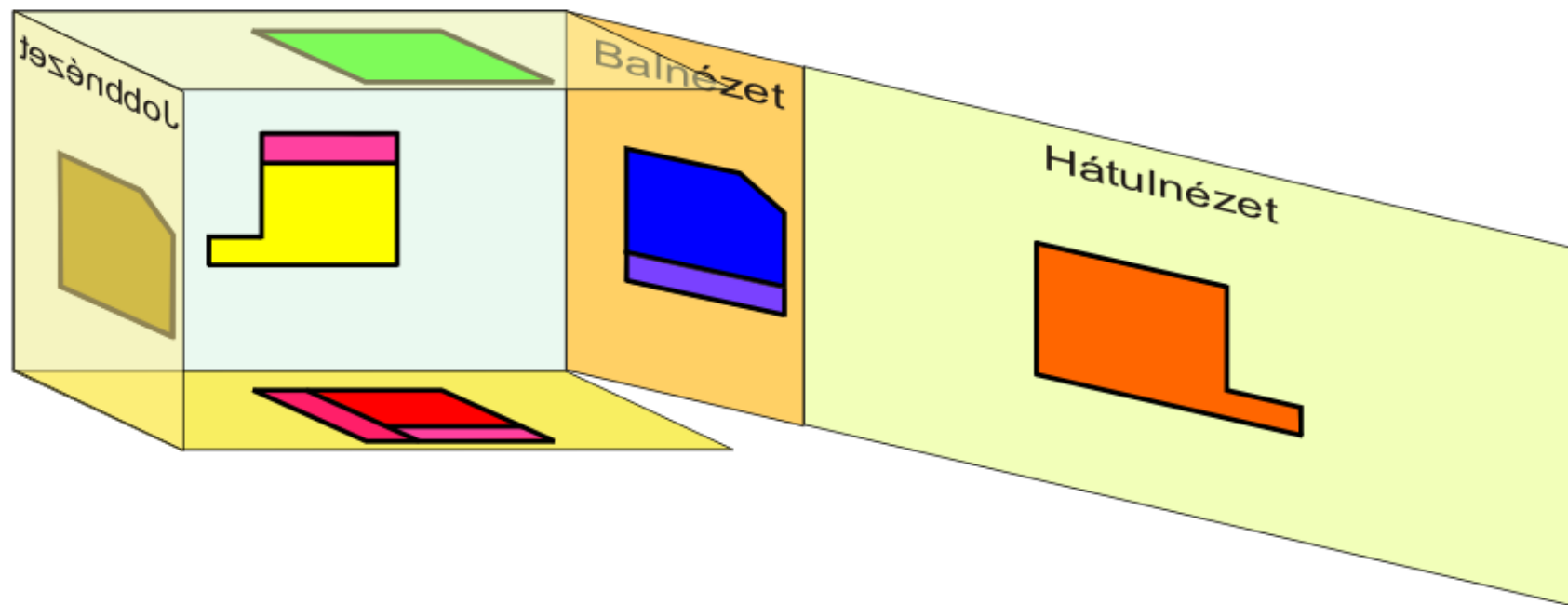

# A „doboz” kiterítése

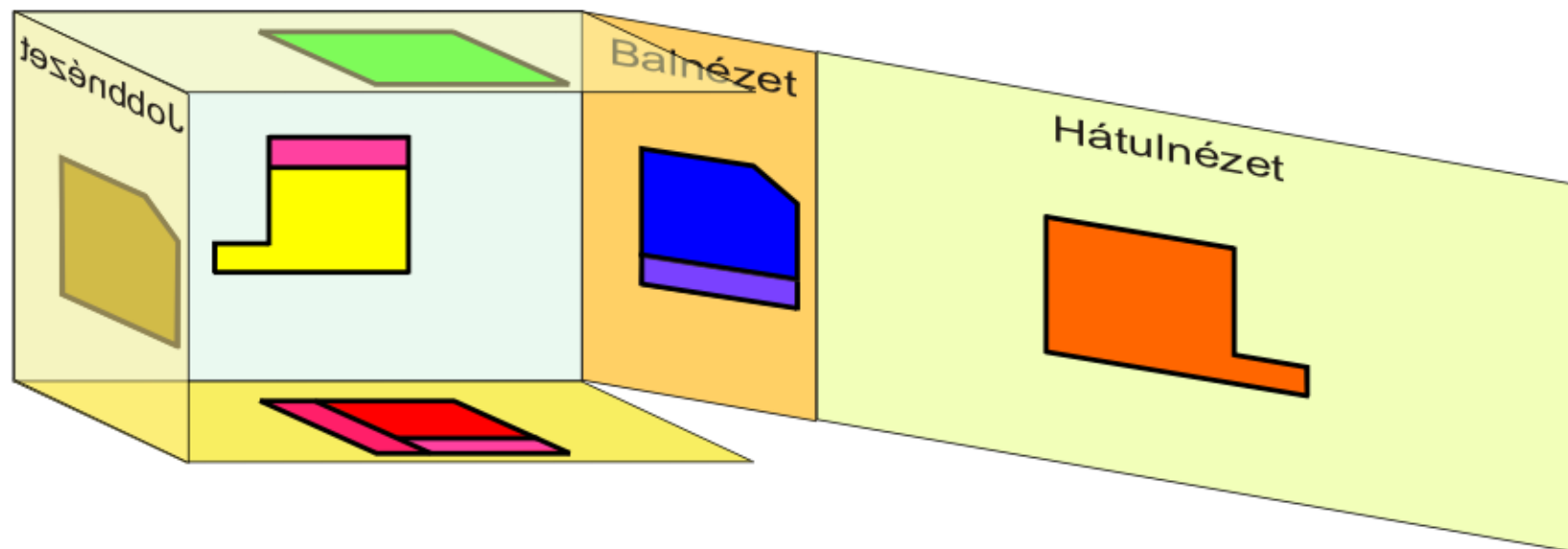



# A „doboz” kiterítése

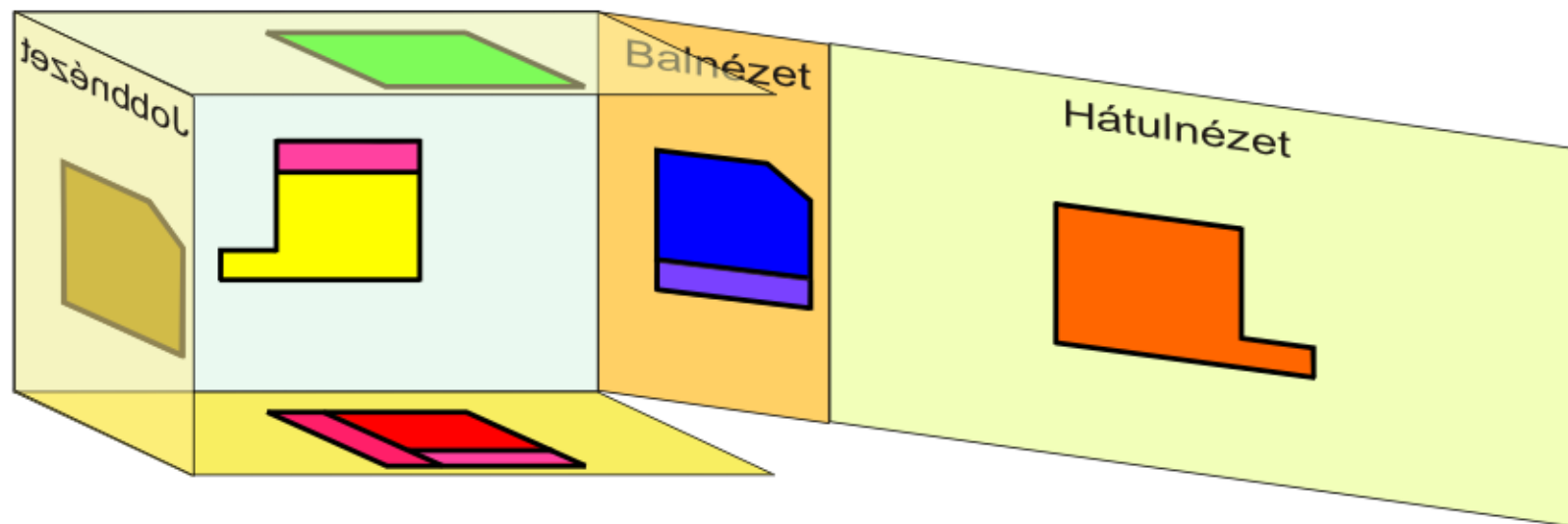

# A „doboz” kiterítése

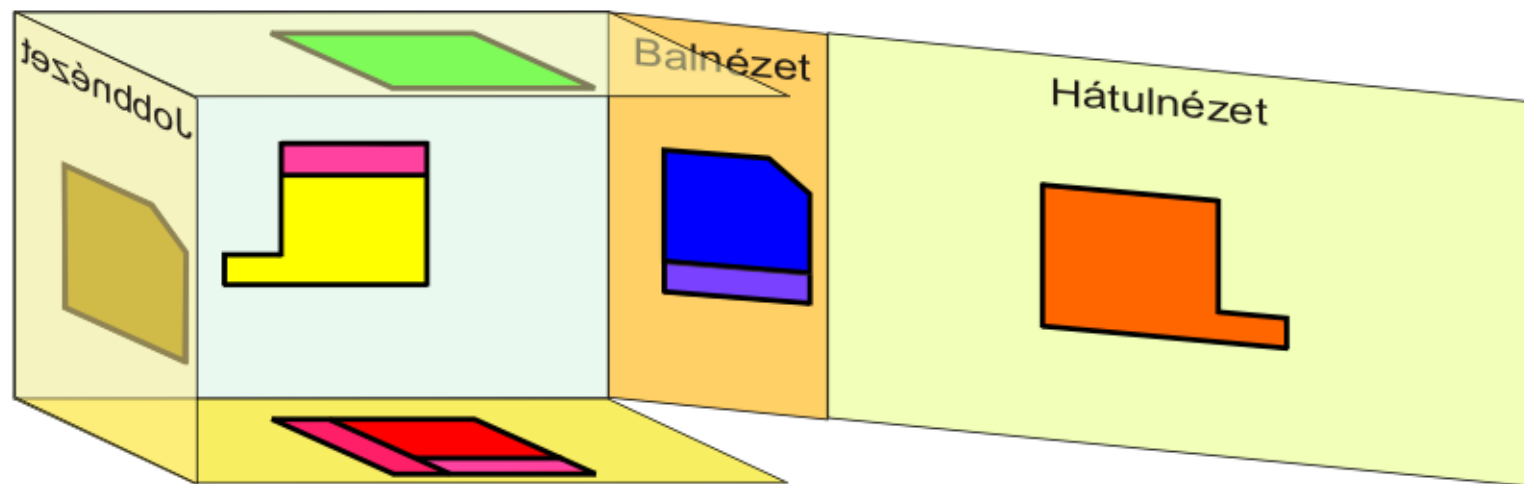

# A „doboz” kiterítése

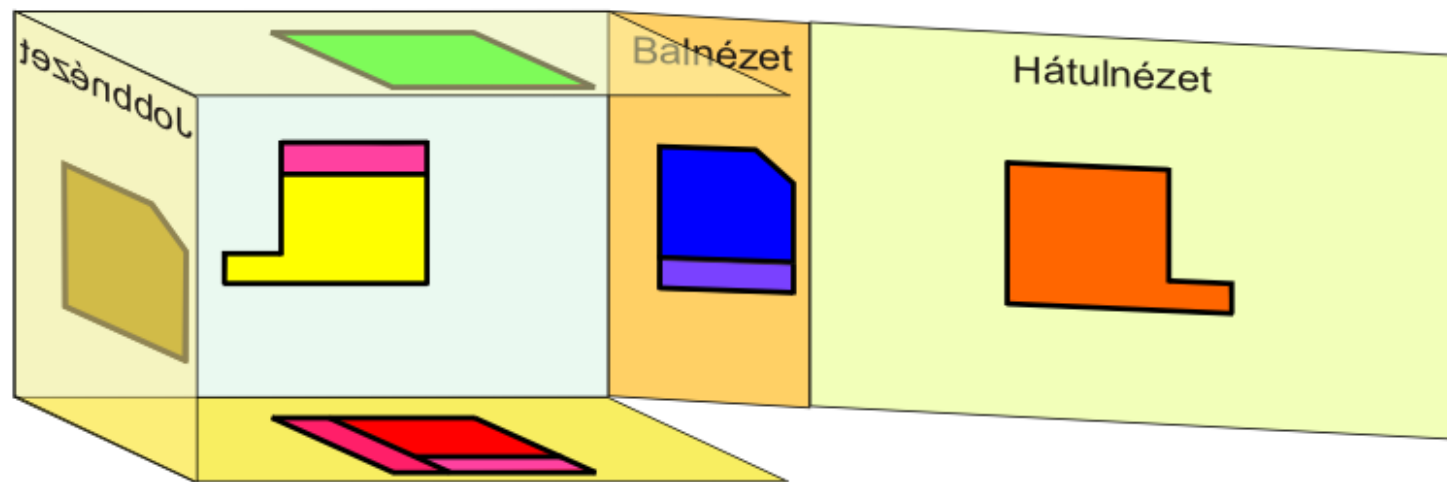

# A „doboz” kiterítése

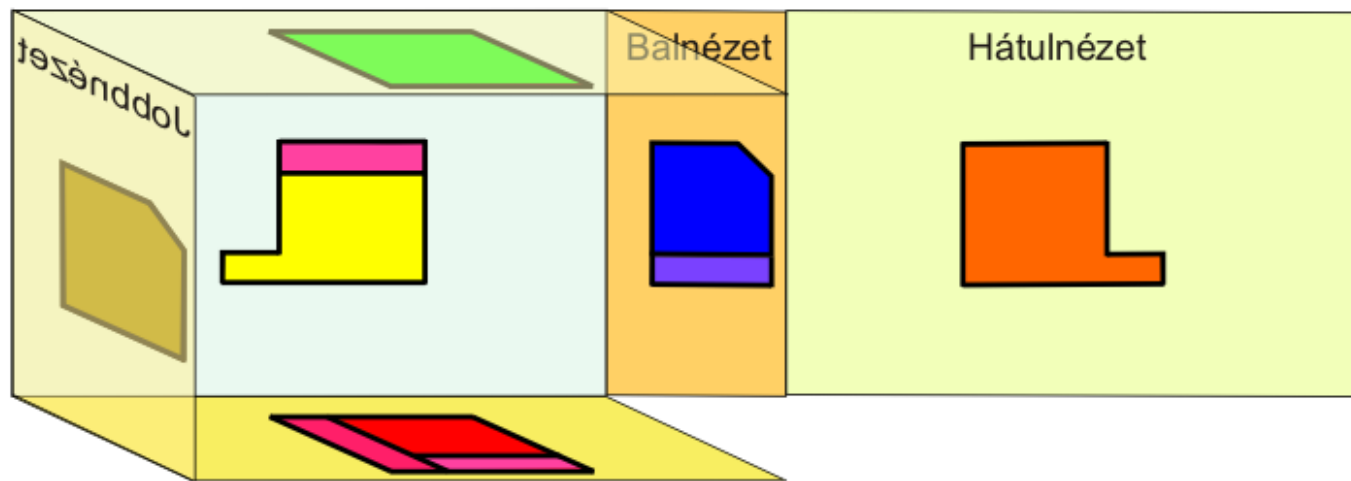

# A „doboz” kiterítése

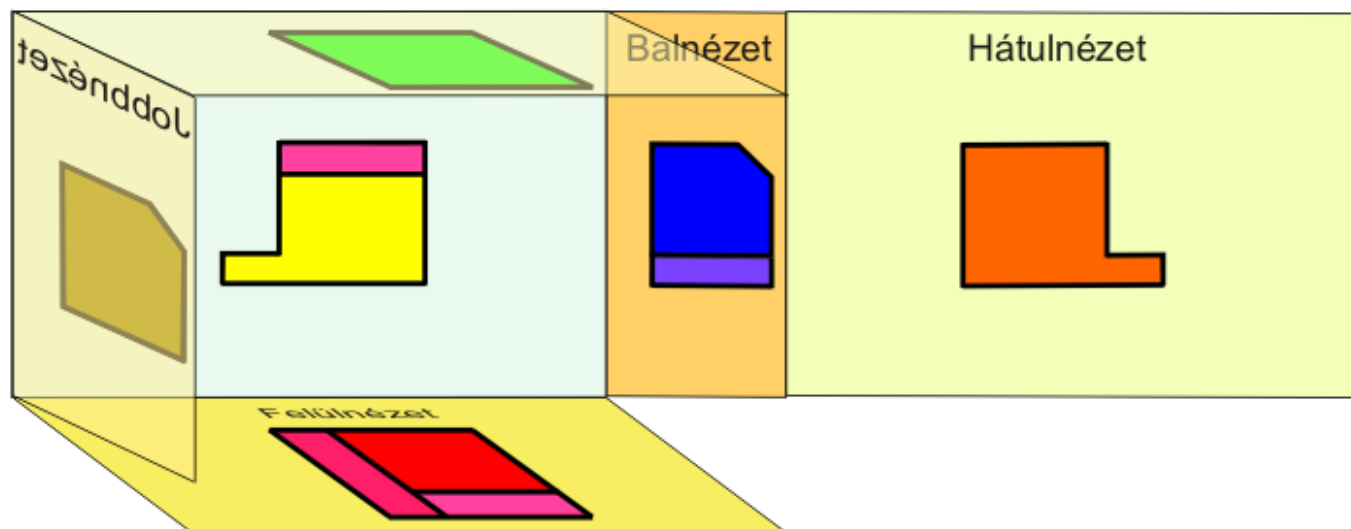

# A „doboz” kiterítése

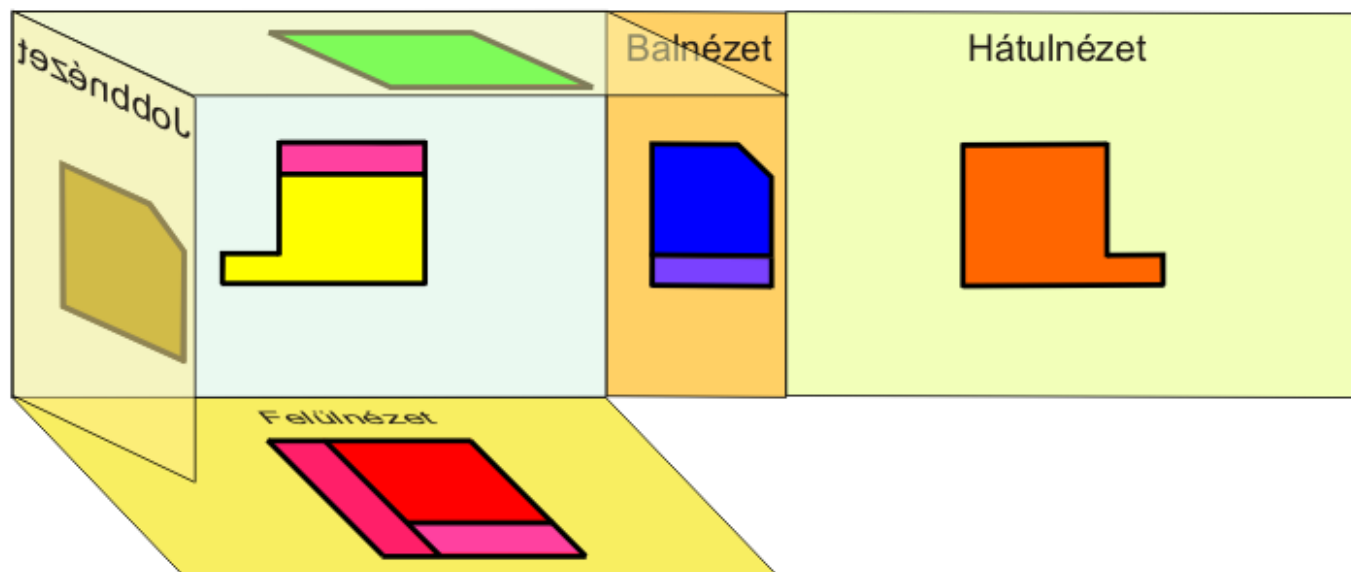

# A „doboz” kiterítése

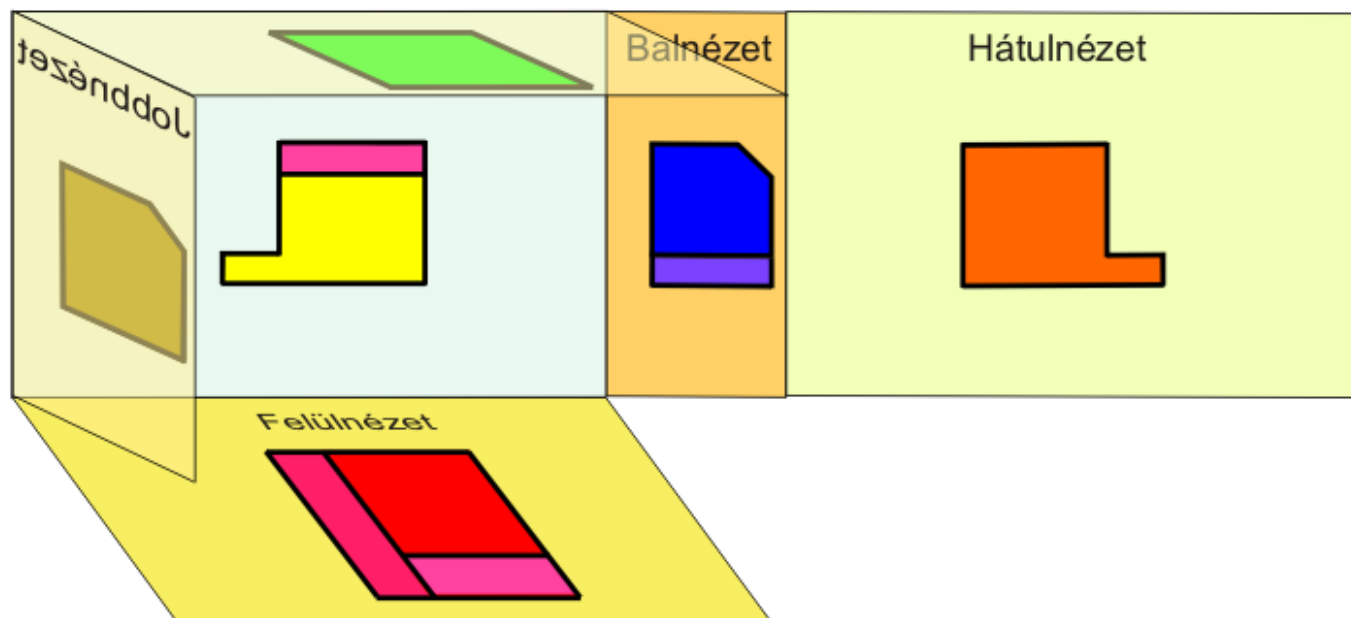

# A „doboz” kiterítése

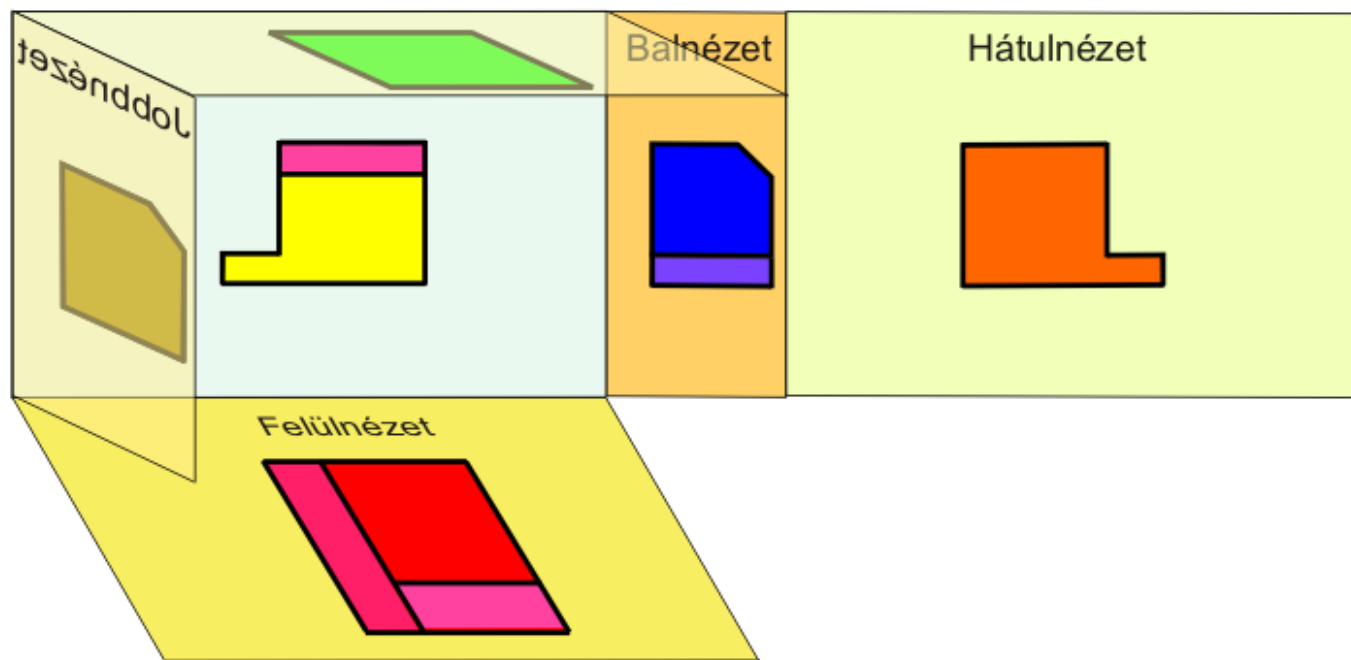



# A „doboz” kiterítése

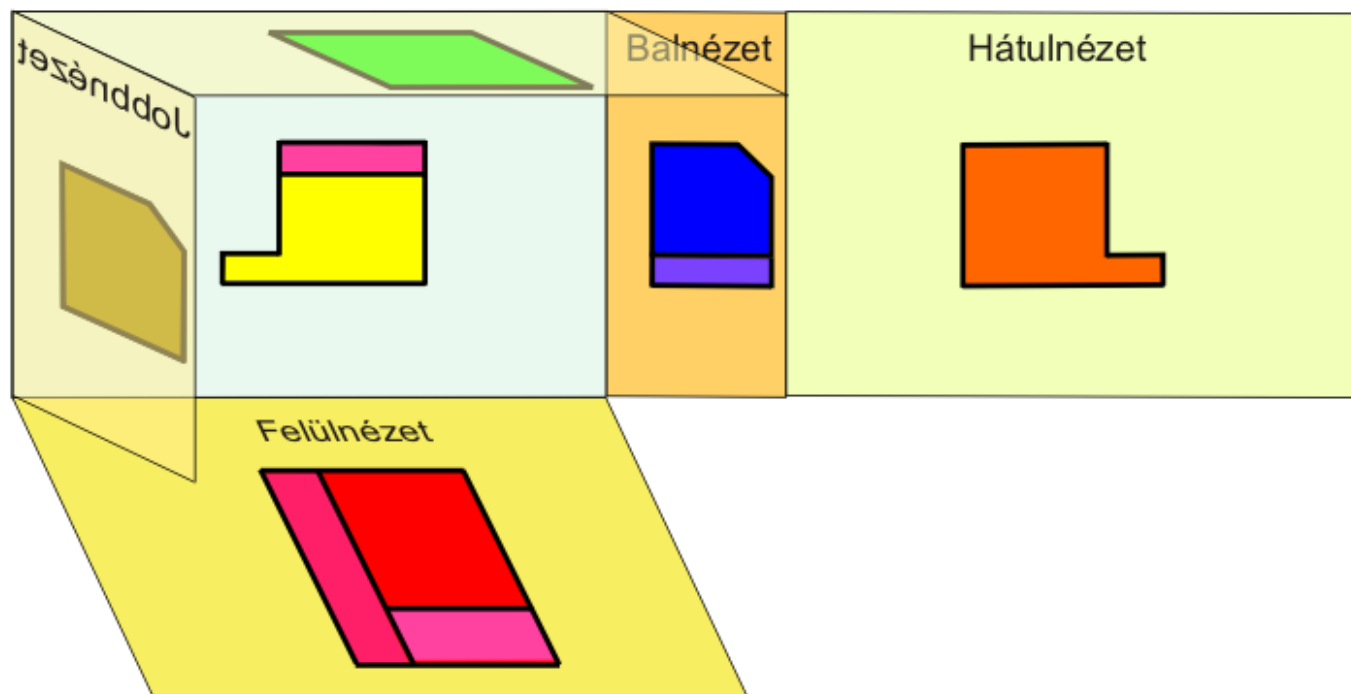

# A „doboz” kiterítése

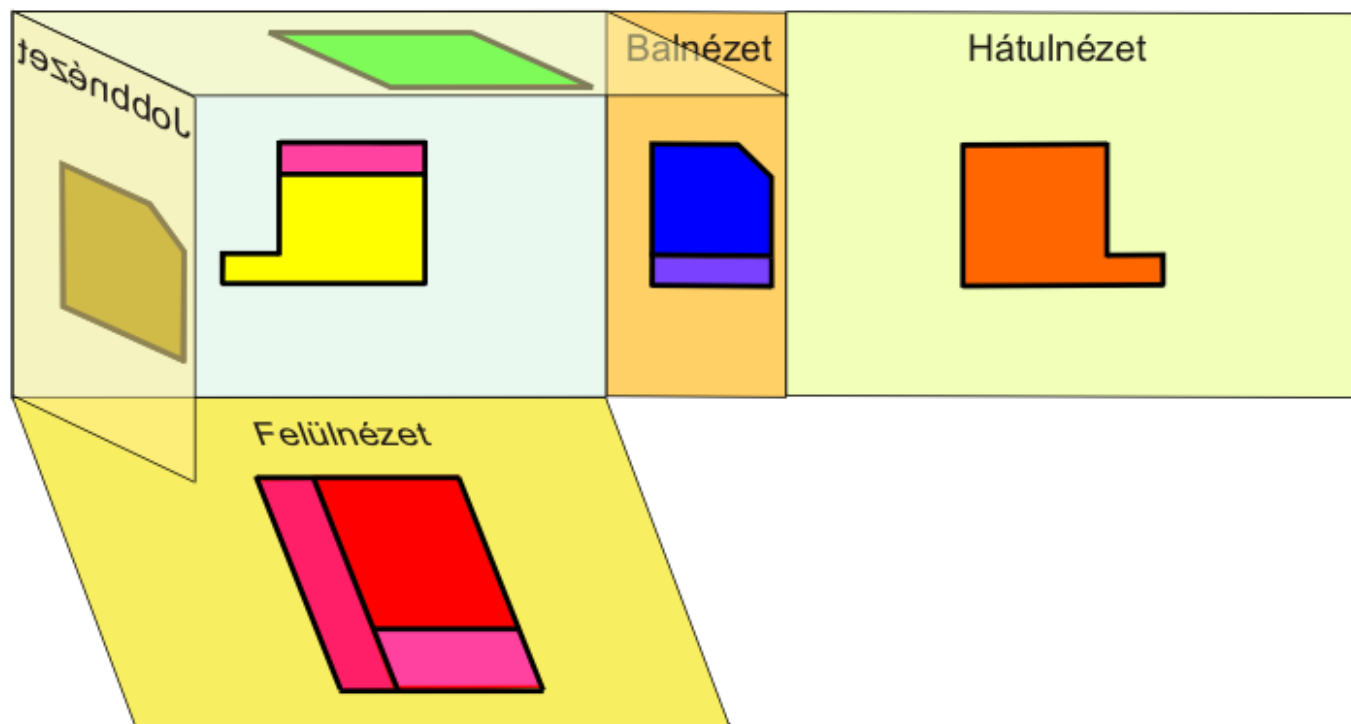

# A „doboz” kiterítése

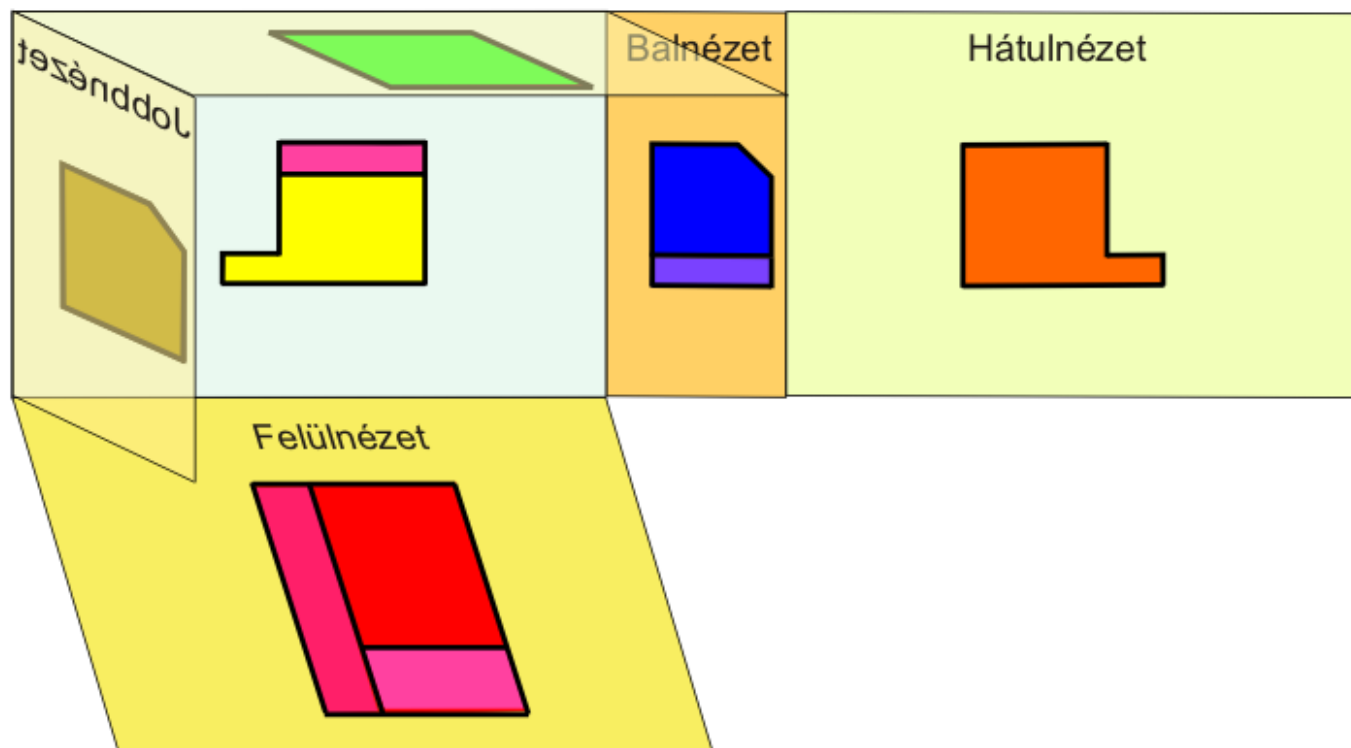

# A „doboz” kiterítése

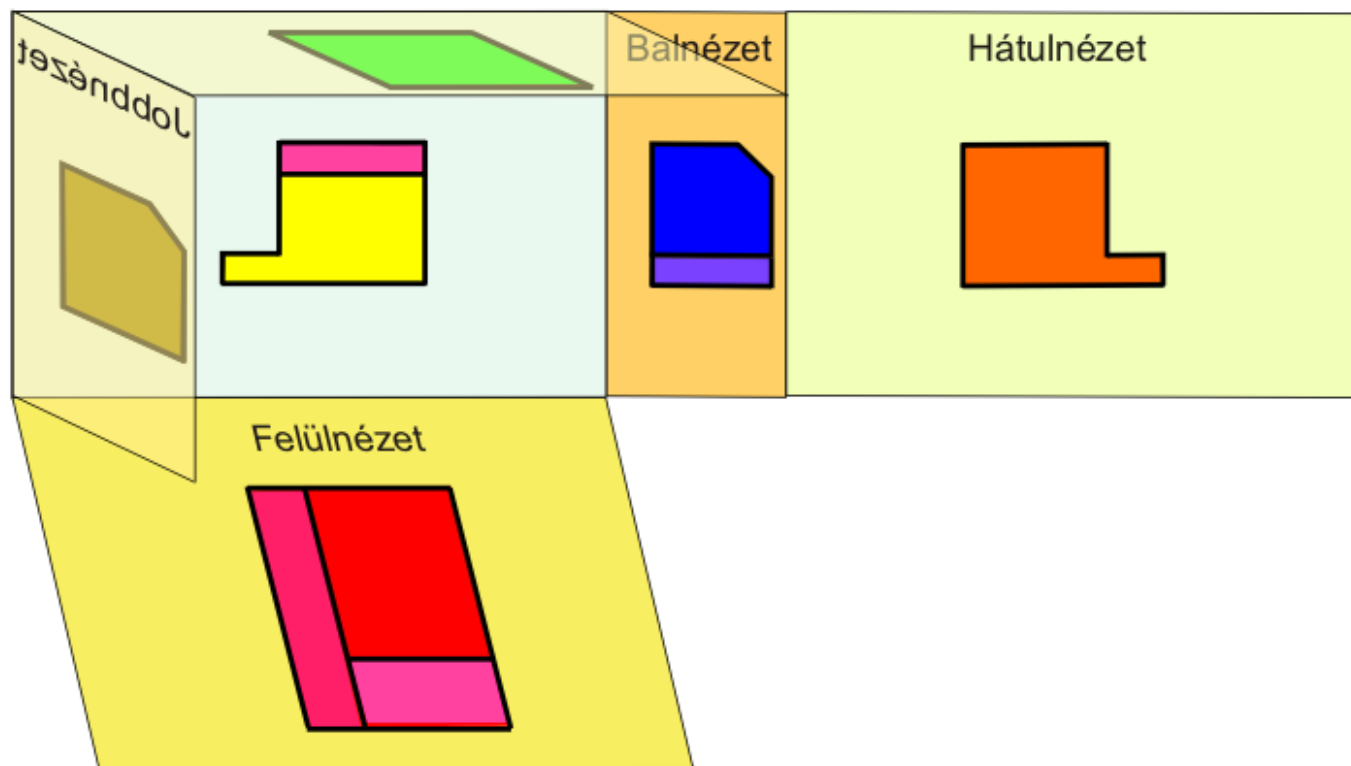

# A „doboz” kiterítése

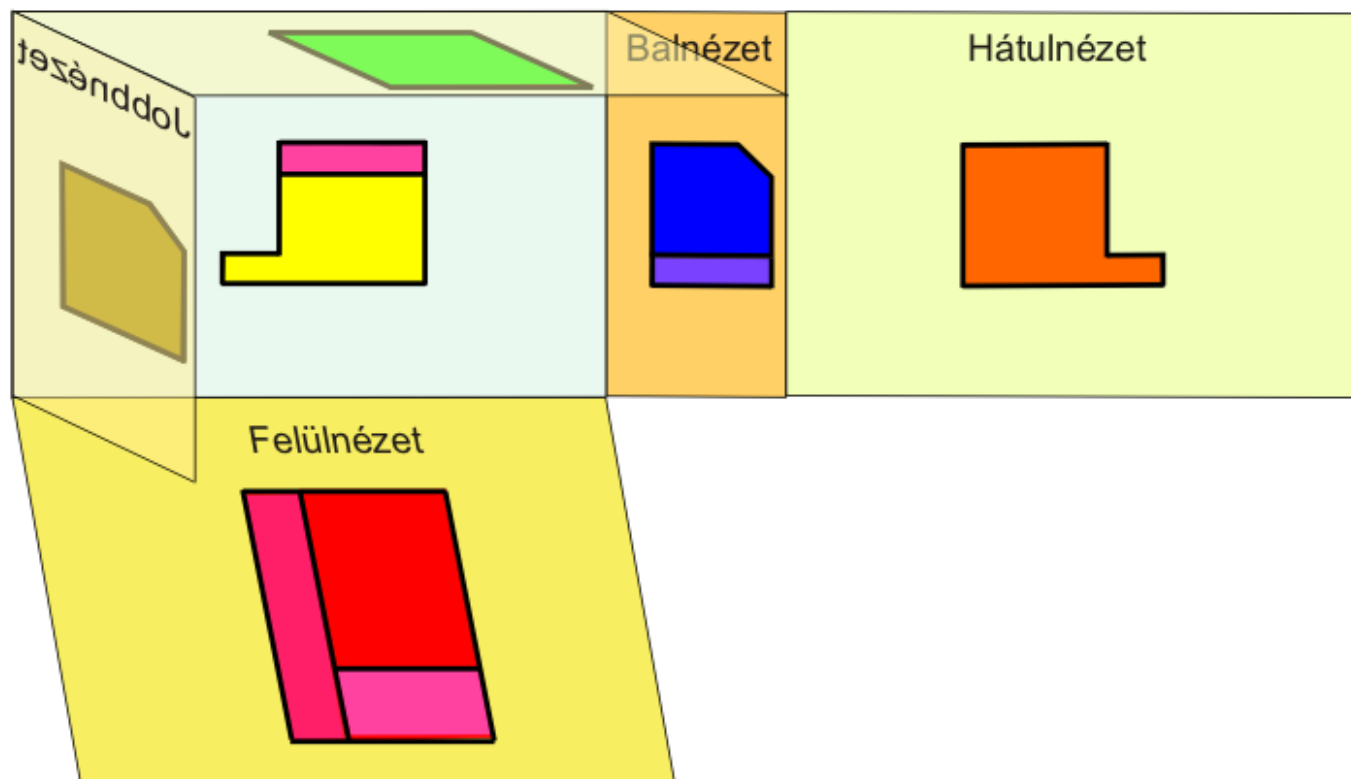

# A „doboz” kiterítése

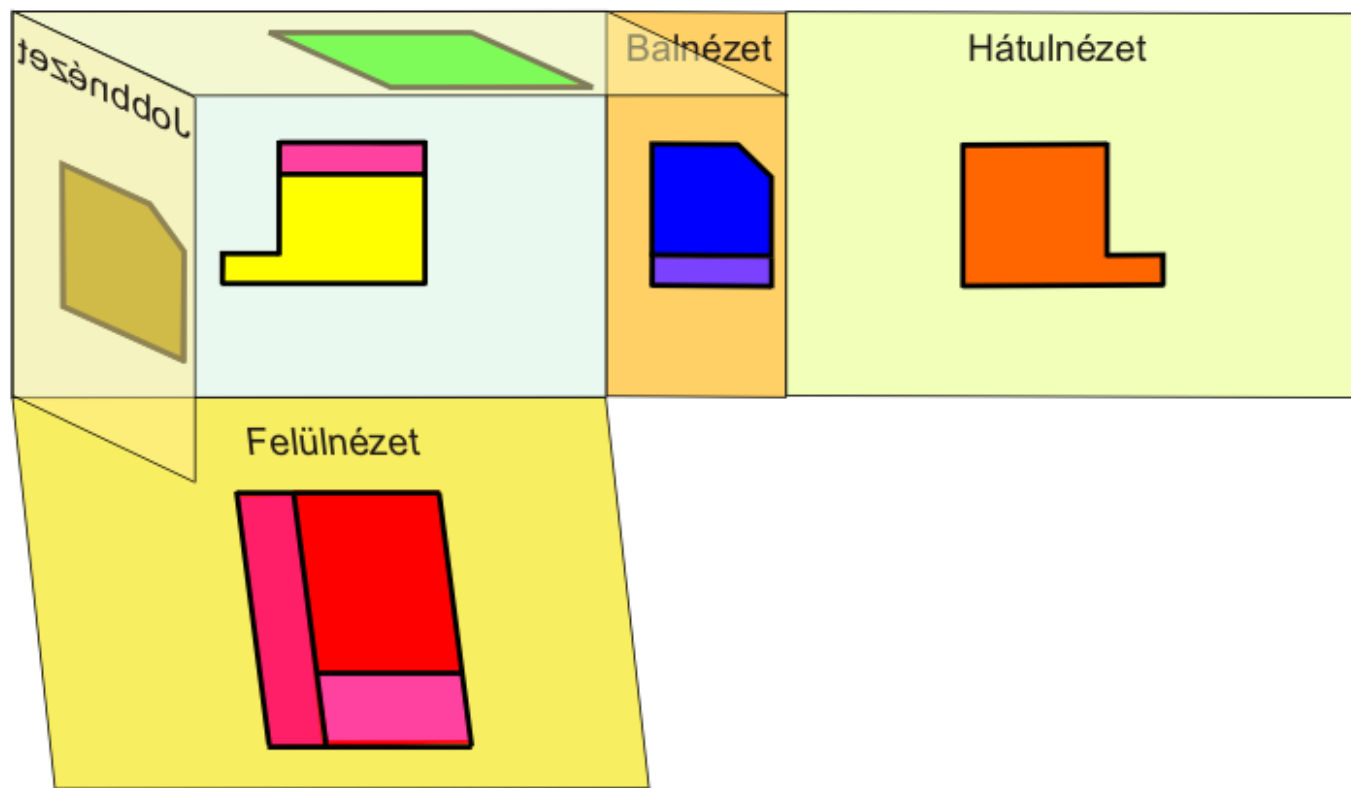

# A „doboz” kiterítése

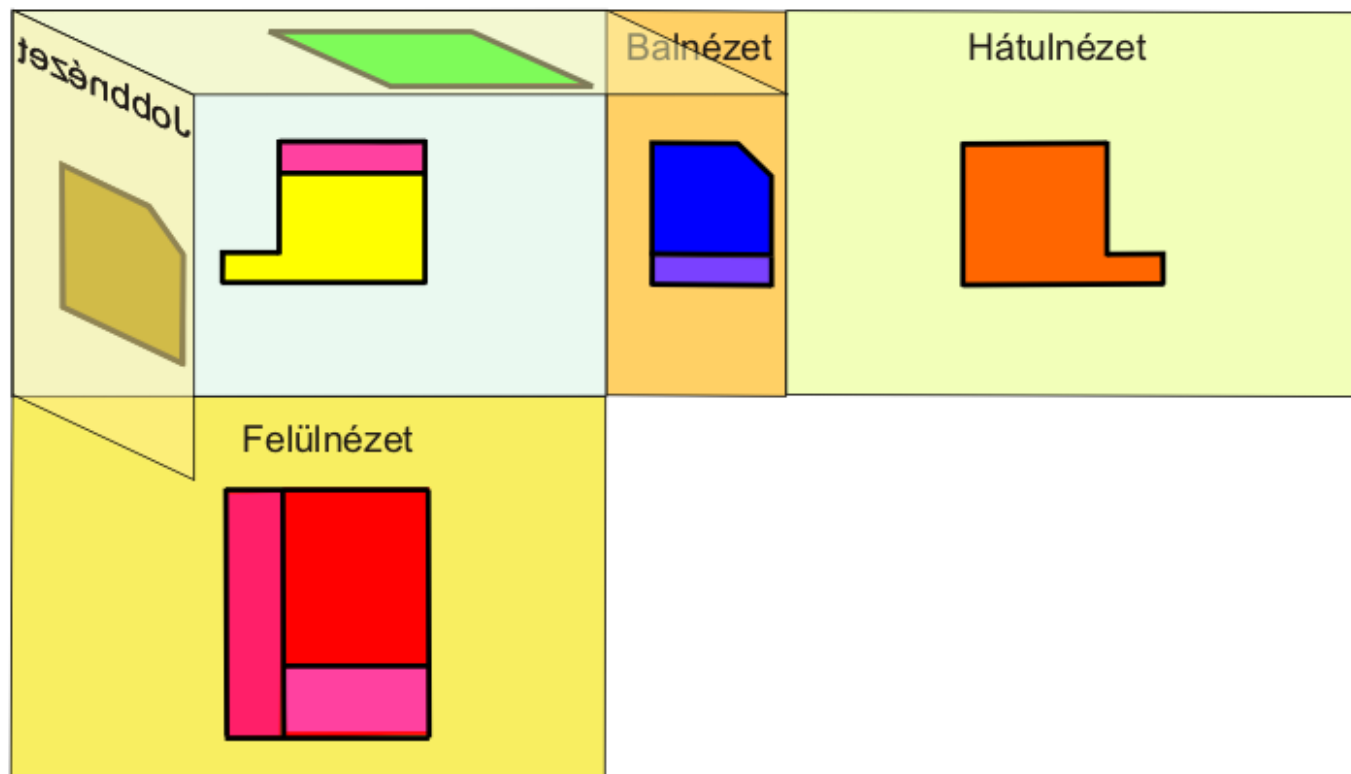

# A „doboz” kiterítése

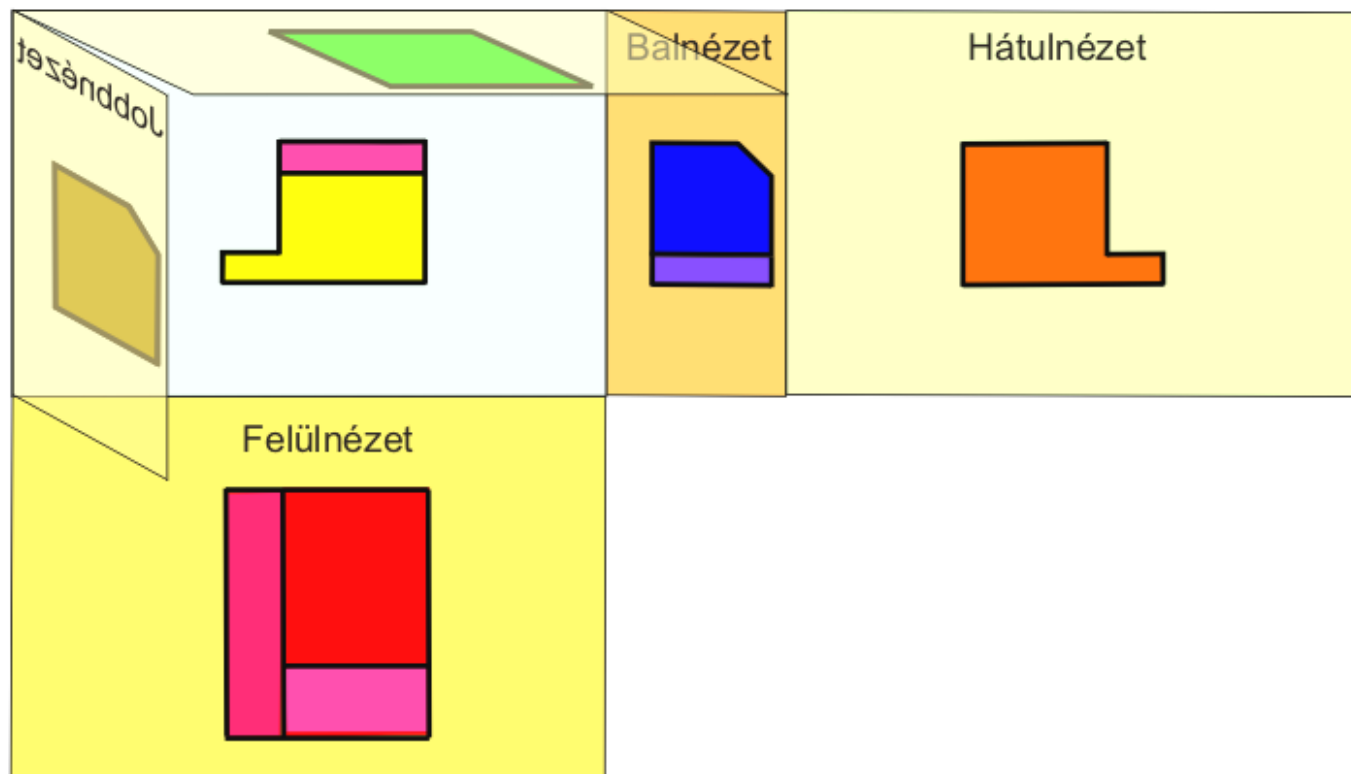



# A „doboz” kiterítése

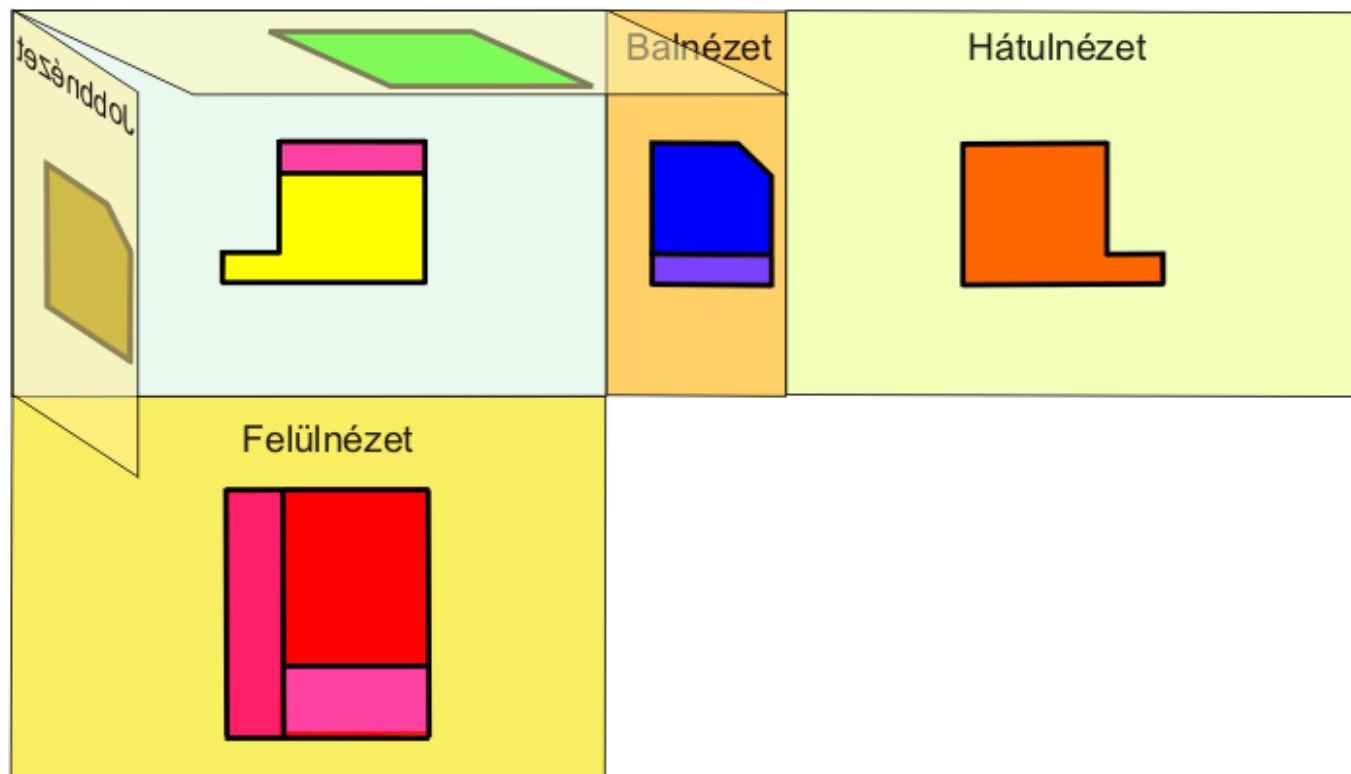

# A „doboz” kiterítése

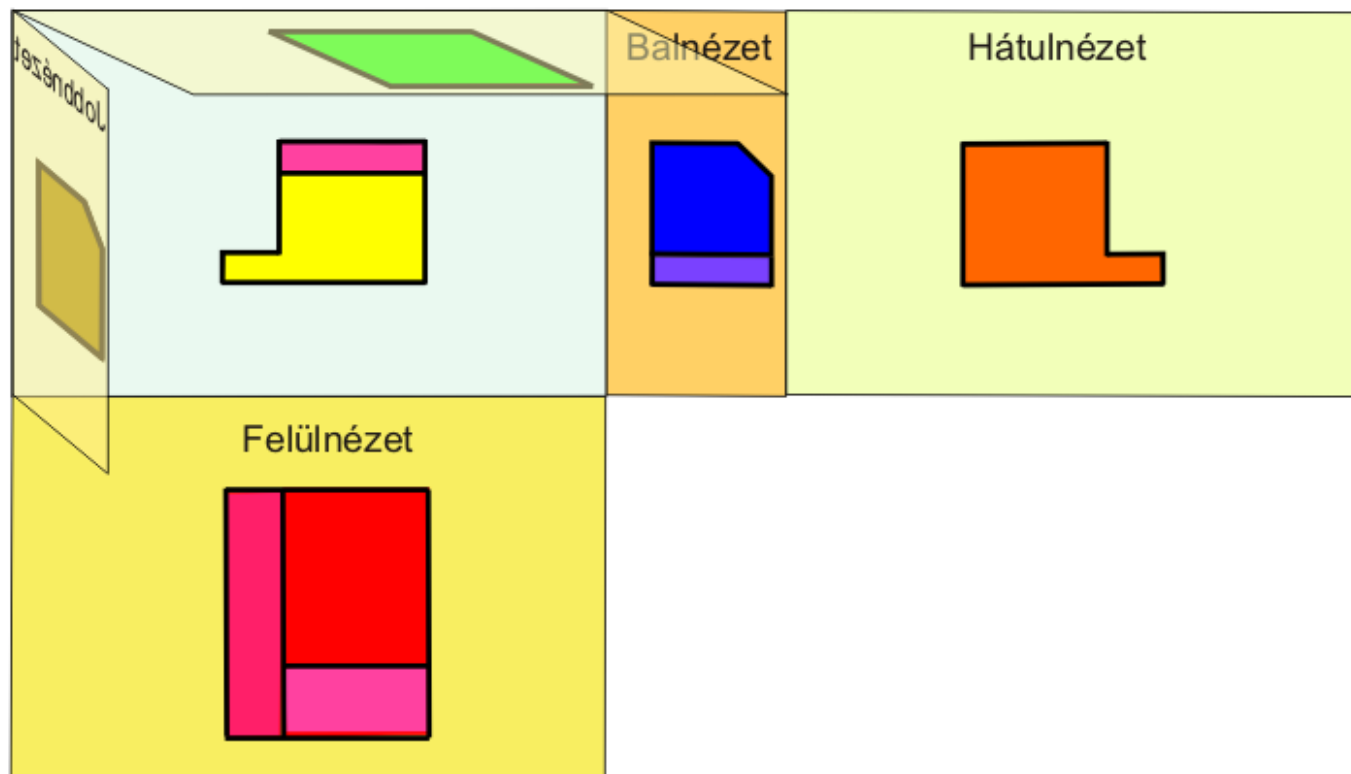

# A „doboz” kiterítése

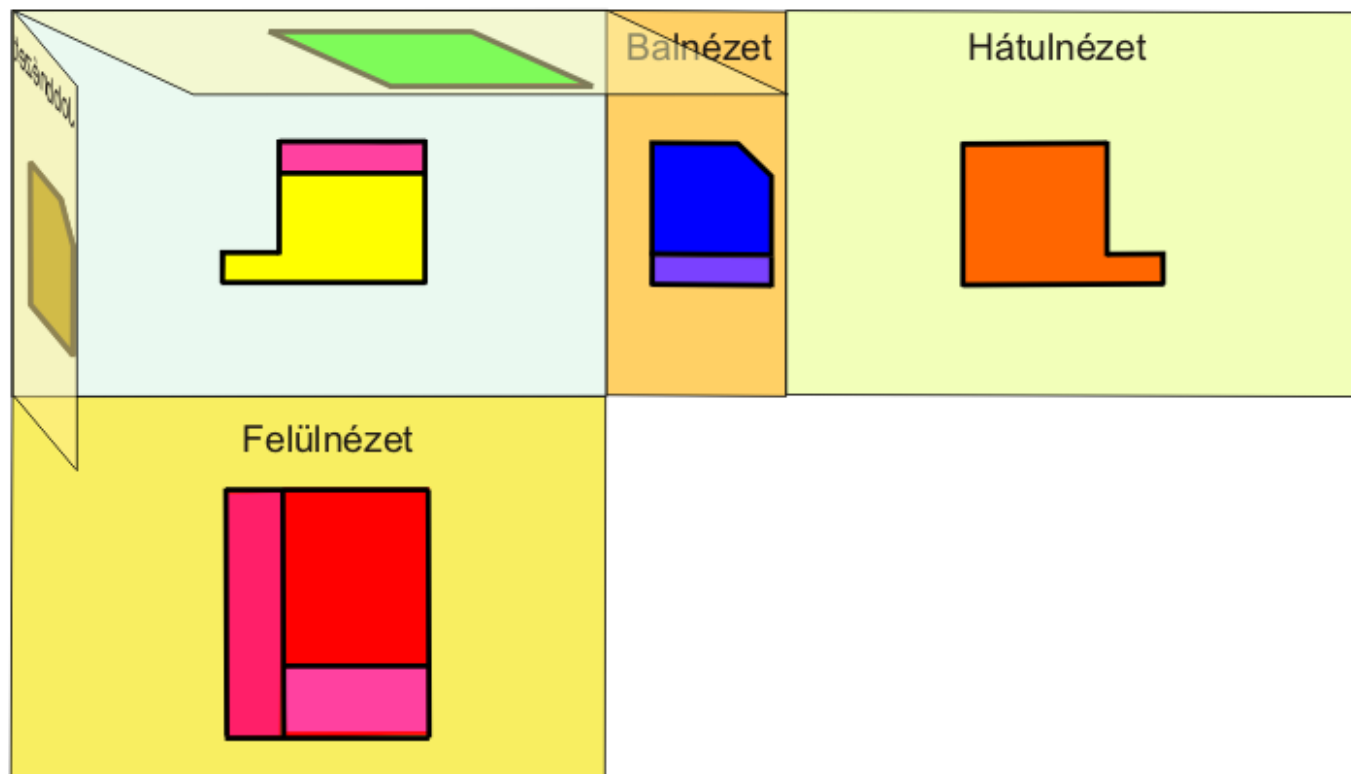

# A „doboz” kiterítése

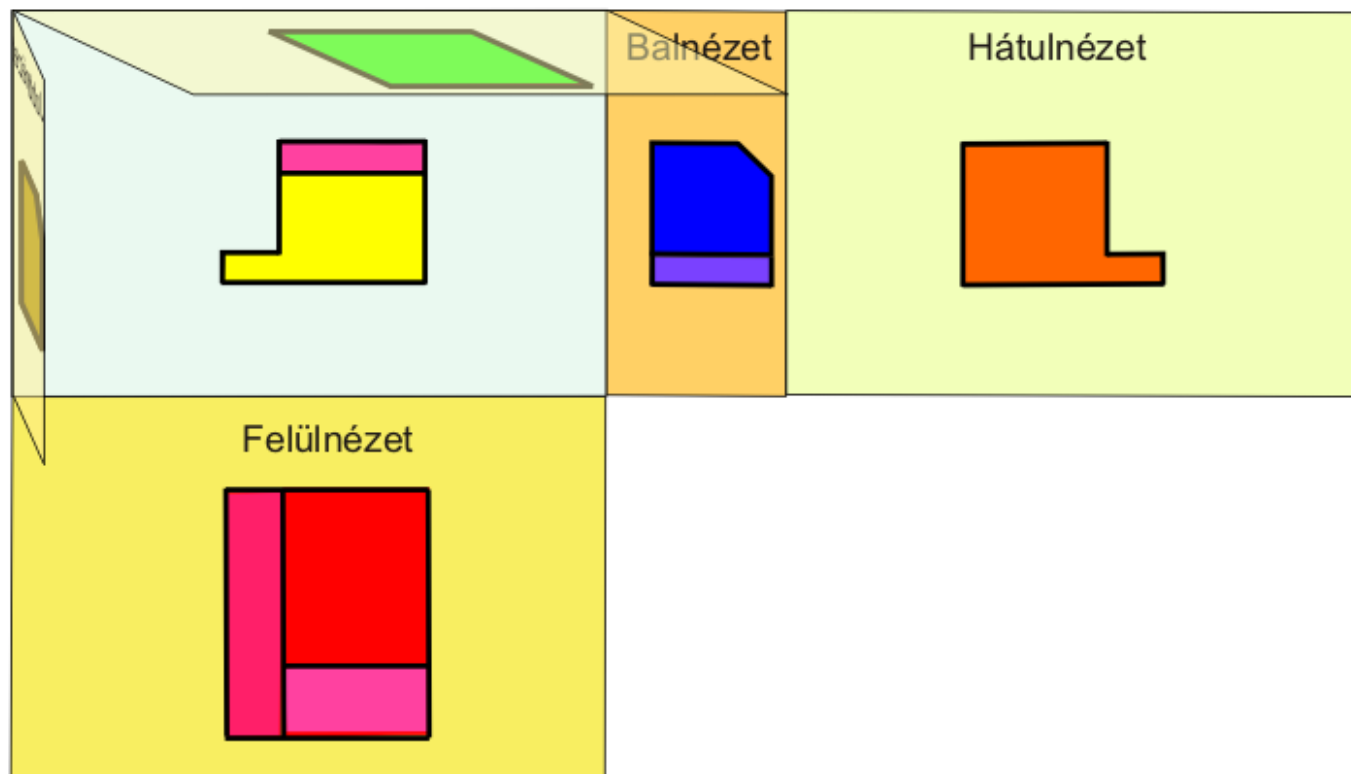

# A „doboz” kiterítése

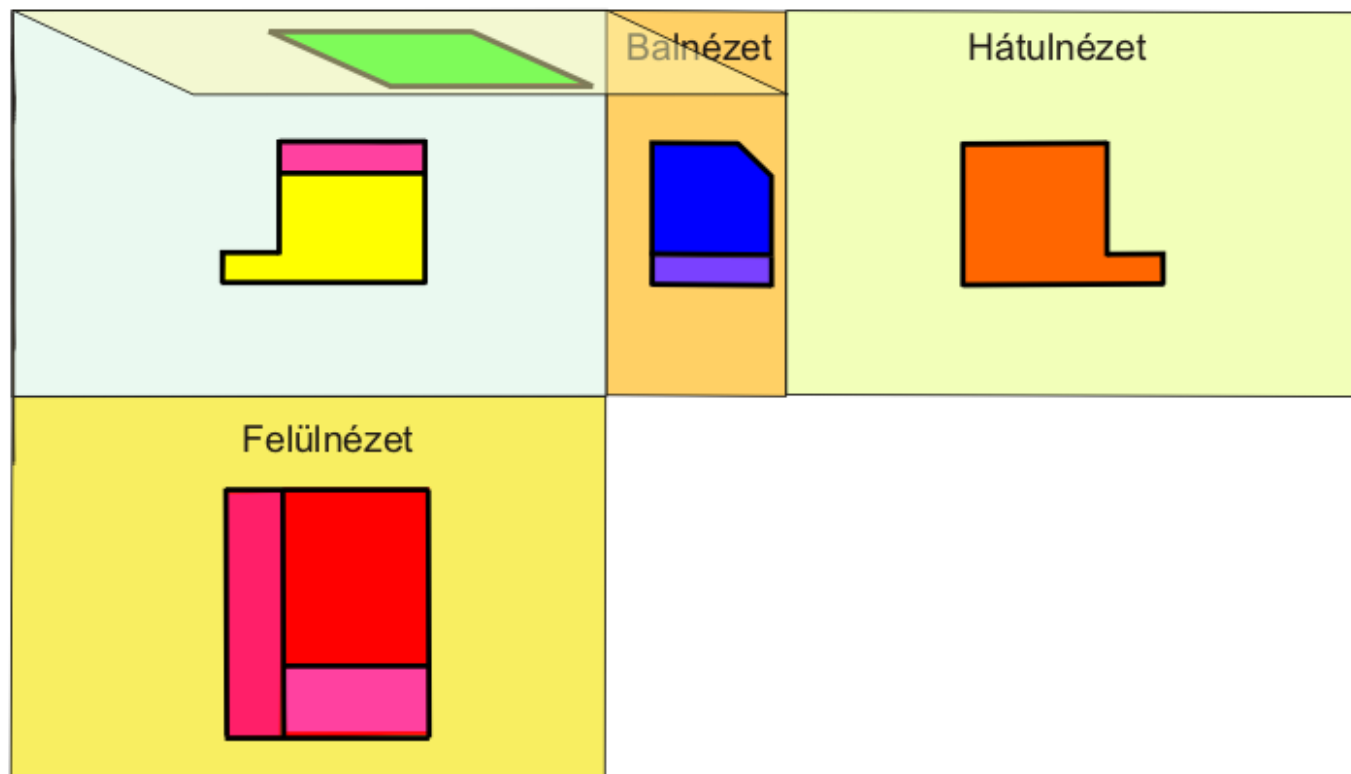

# A „doboz” kiterítése

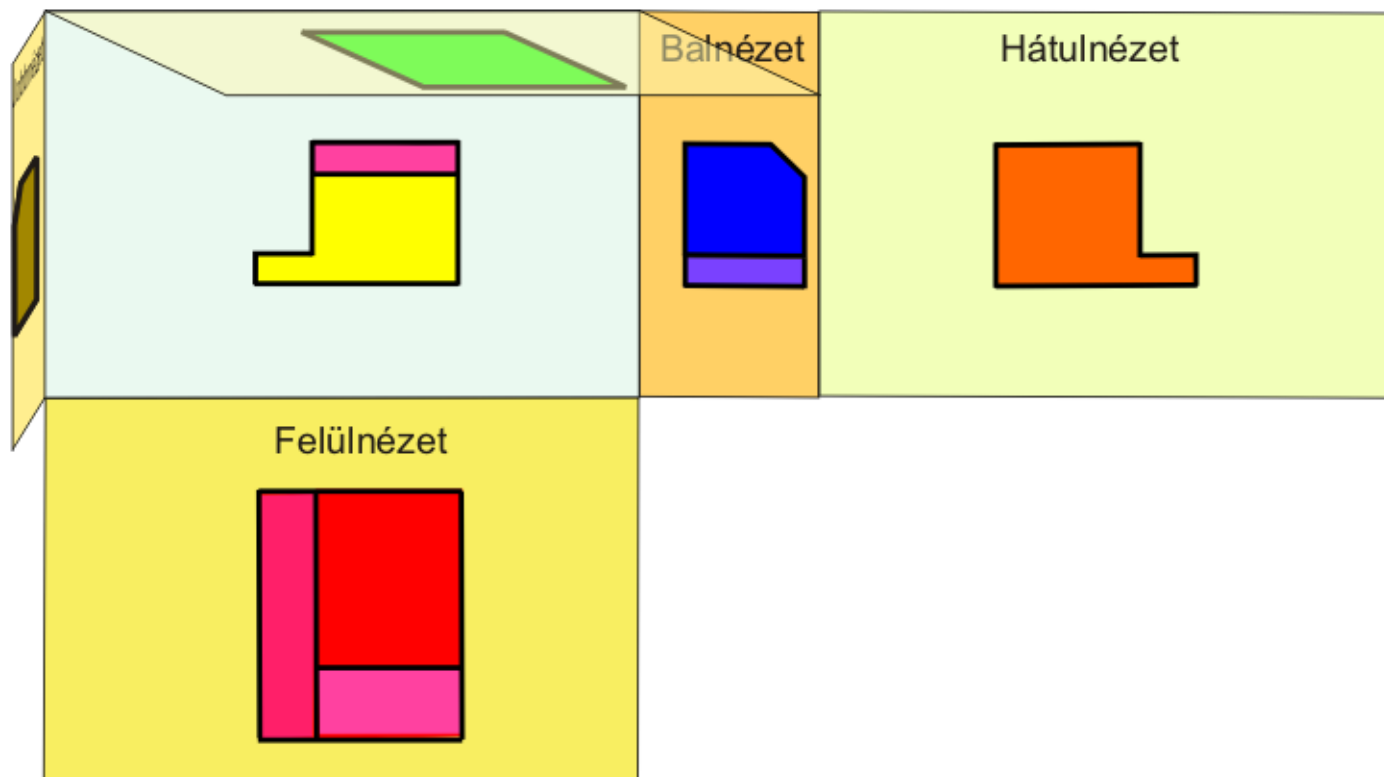

# A „doboz” kiterítése

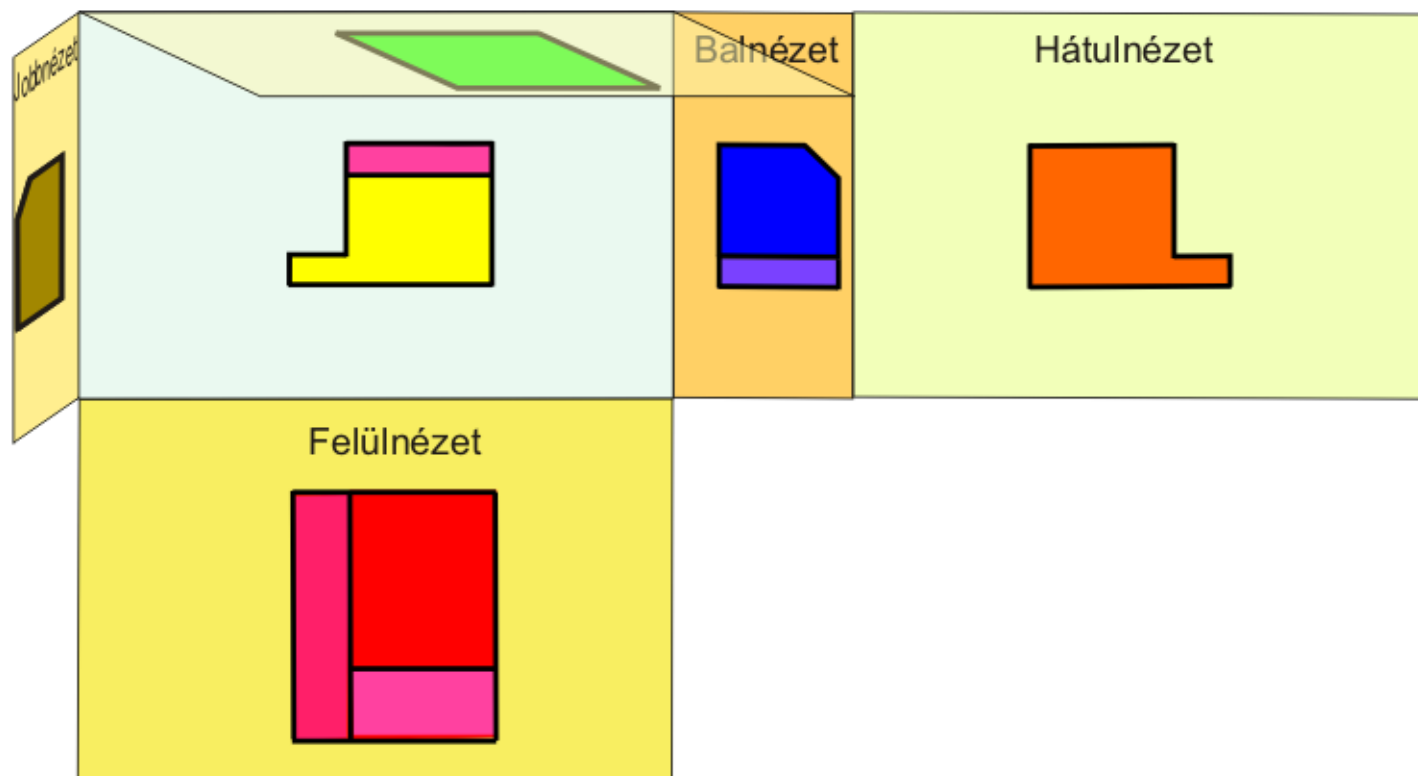

# A „doboz” kiterítése

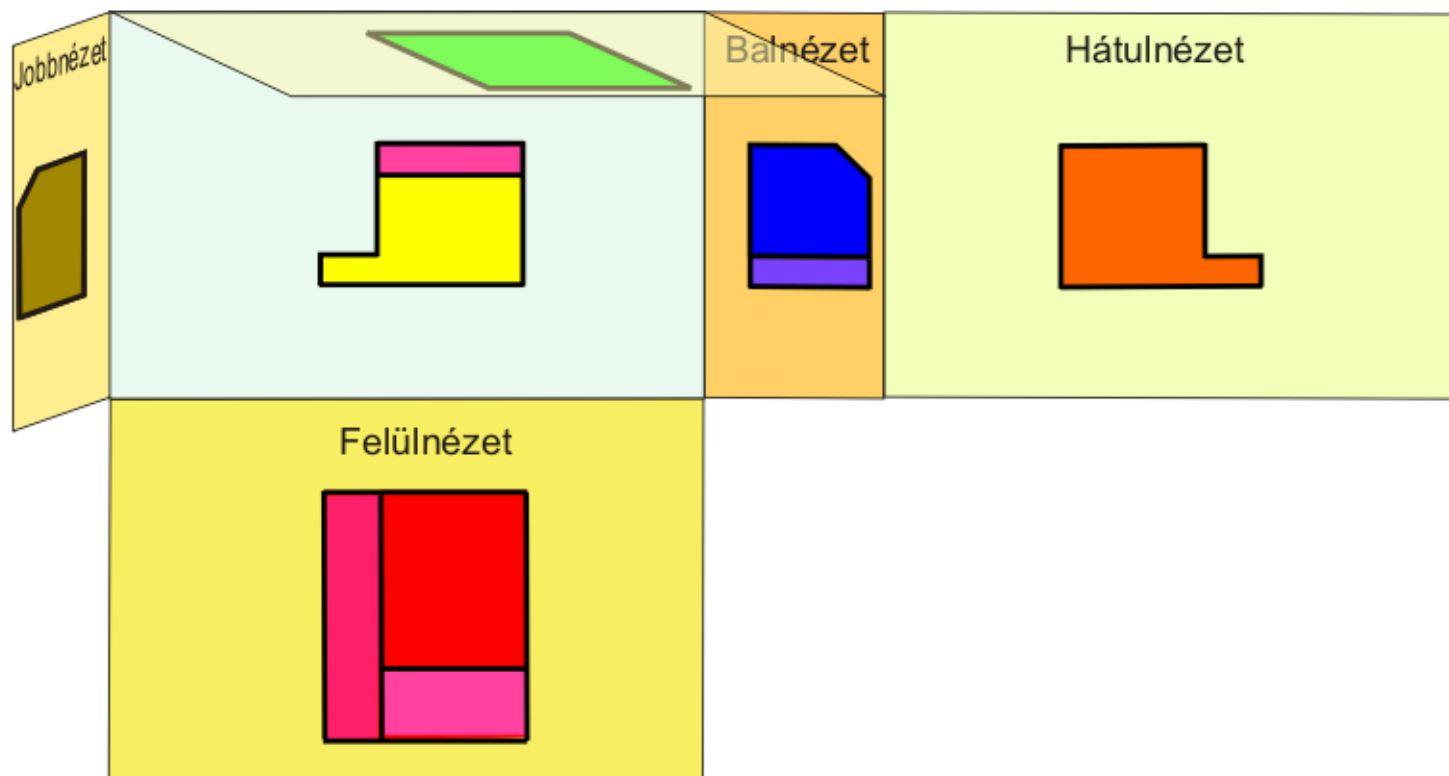



# A „doboz” kiterítése

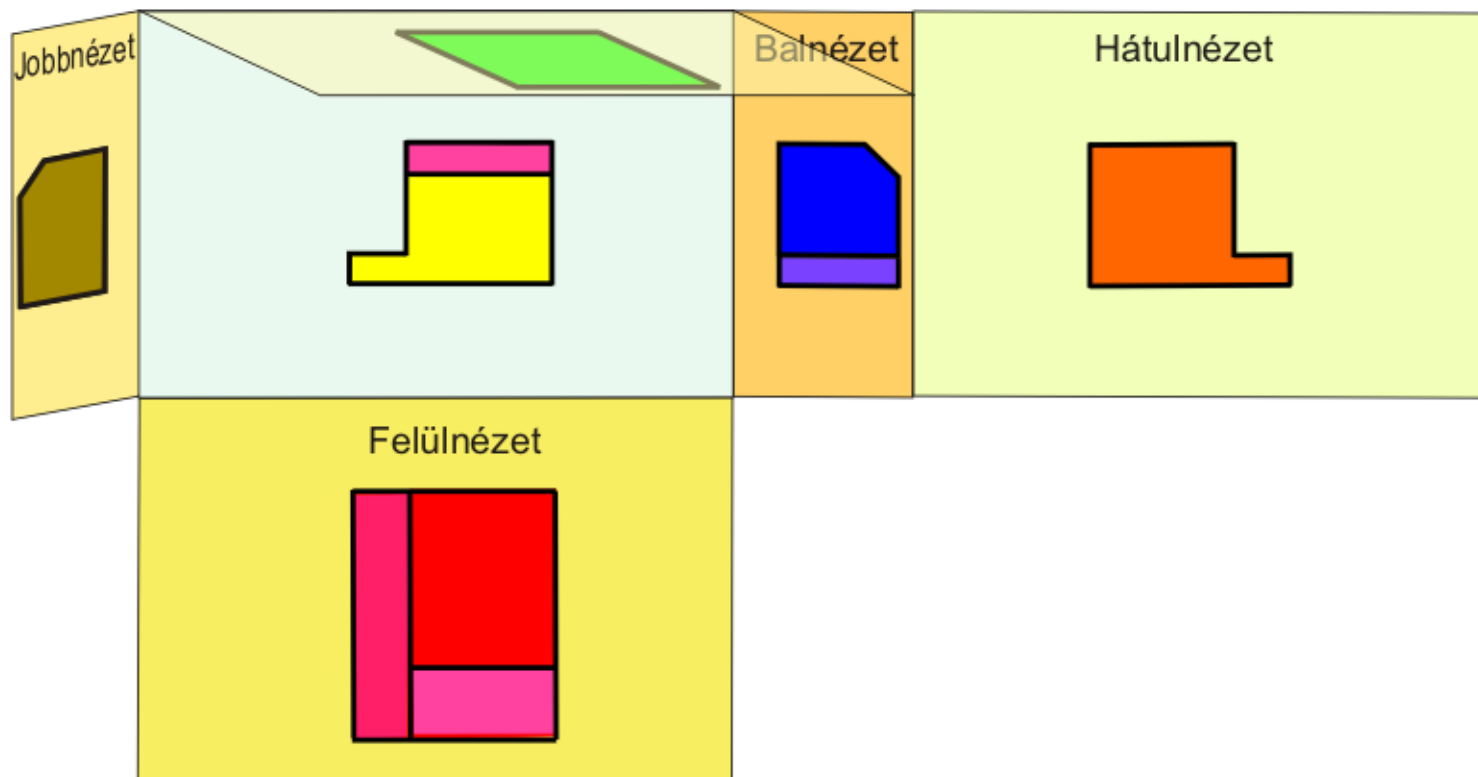

# A „doboz” kiterítése

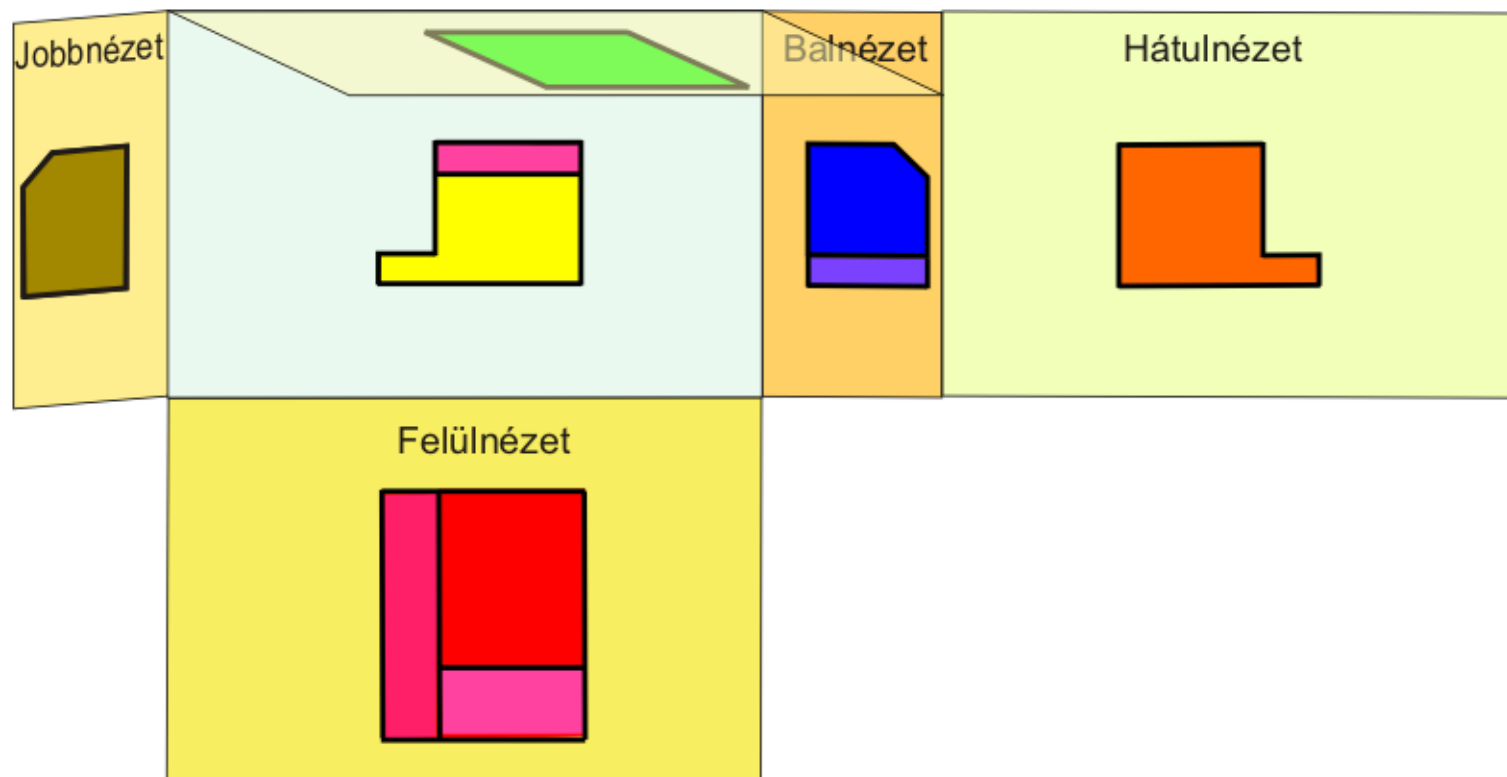

# A „doboz” kiterítése

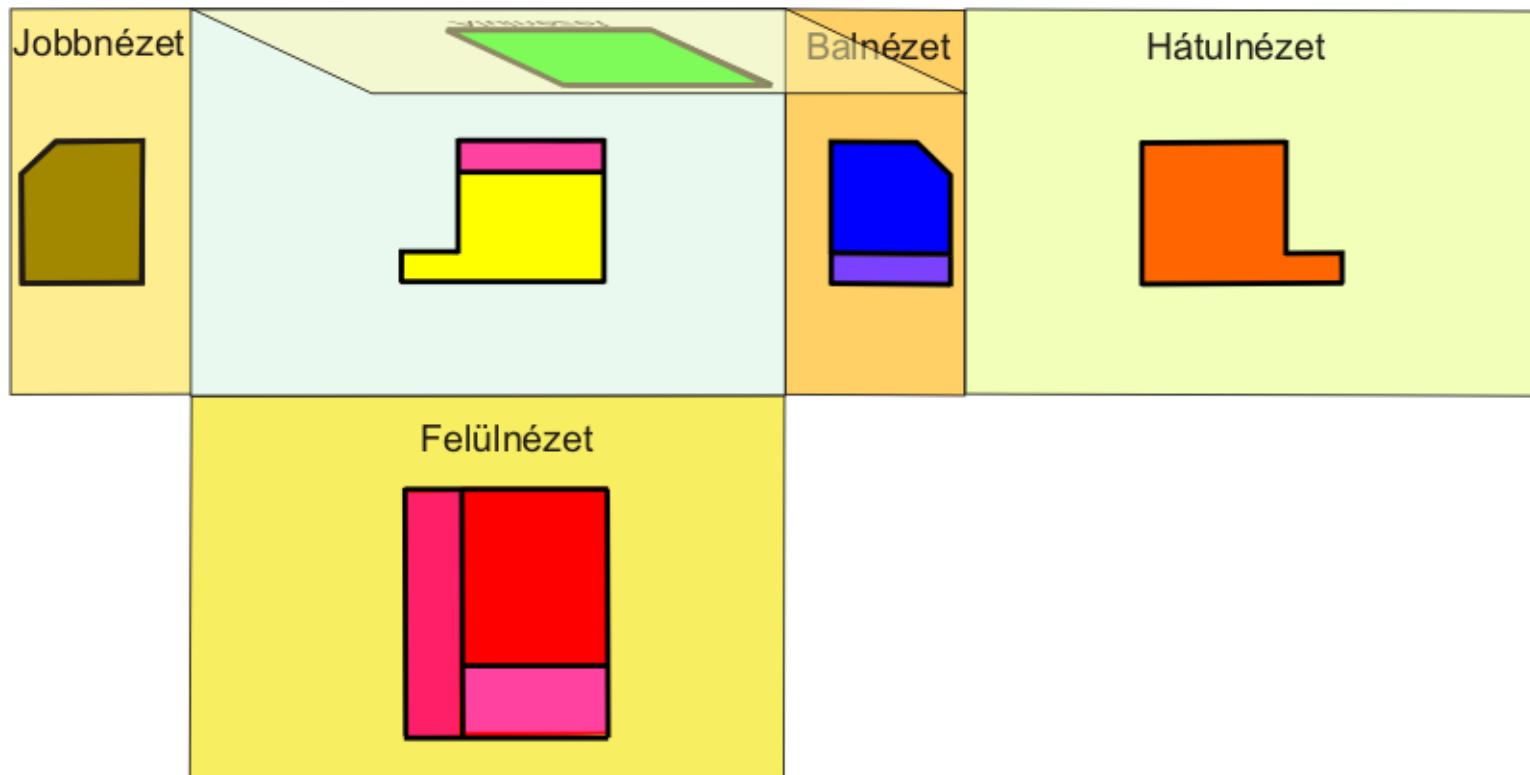

# A „doboz” kiterítése

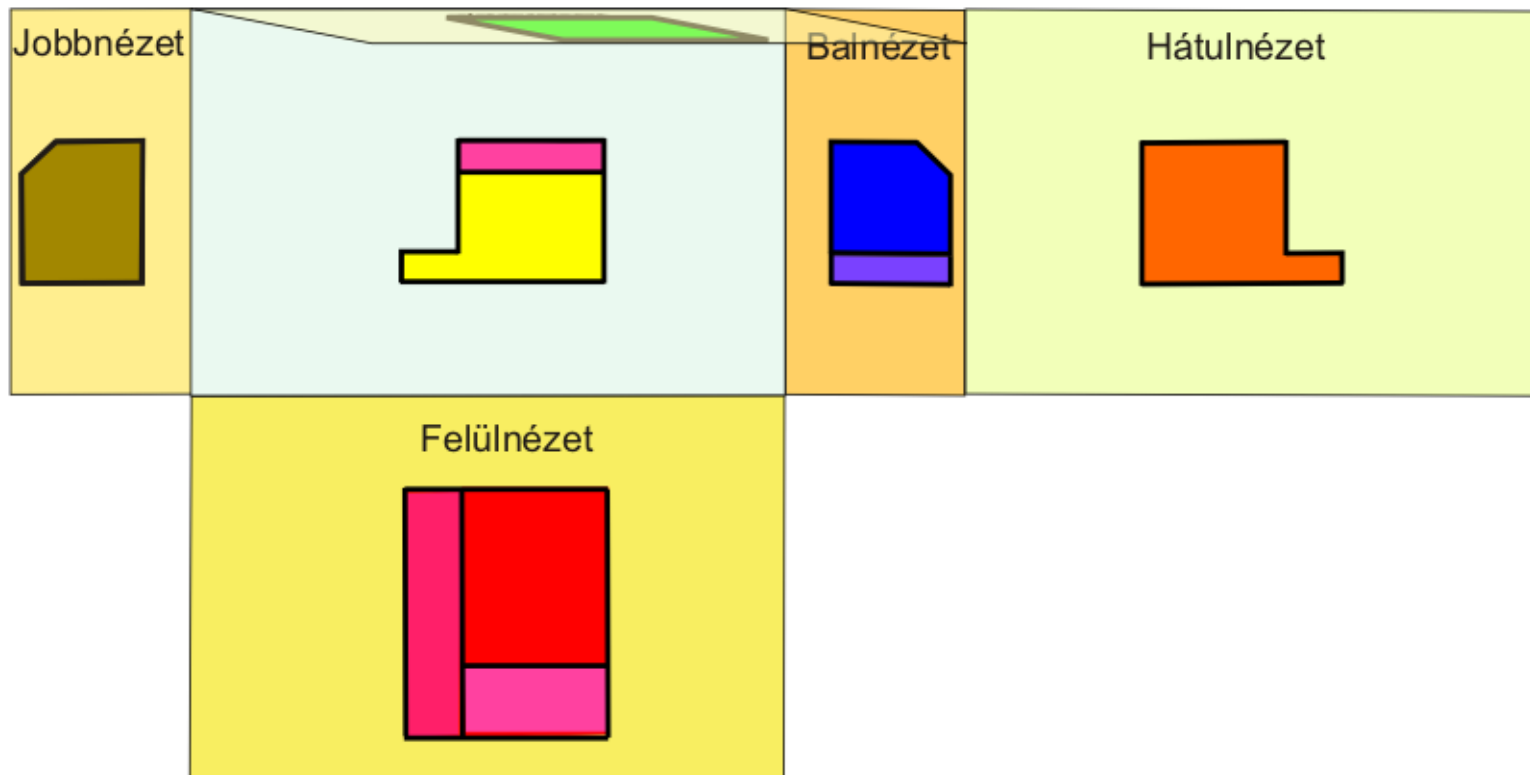

# A „doboz” kiterítése

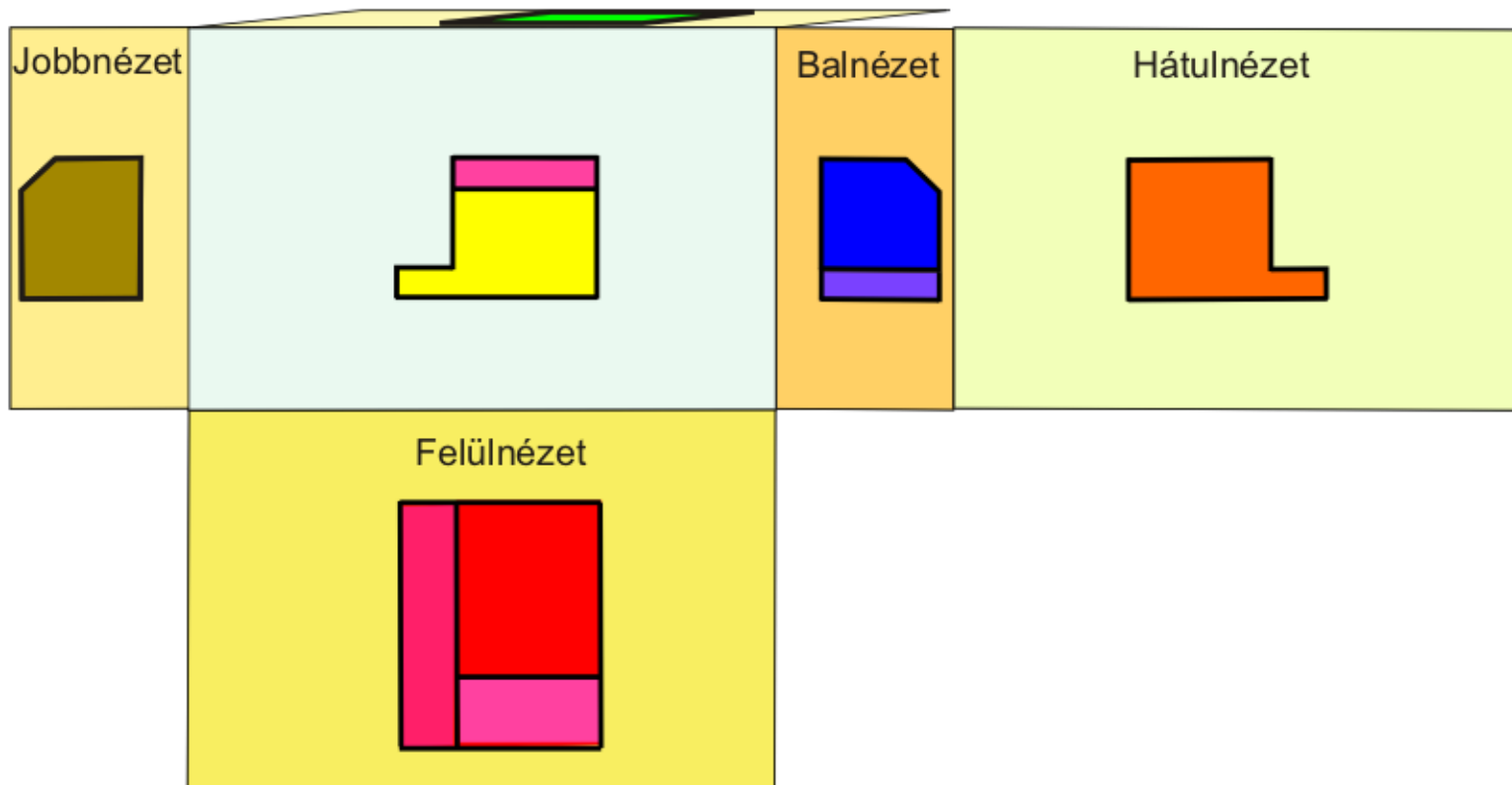

# A „doboz” kiterítése

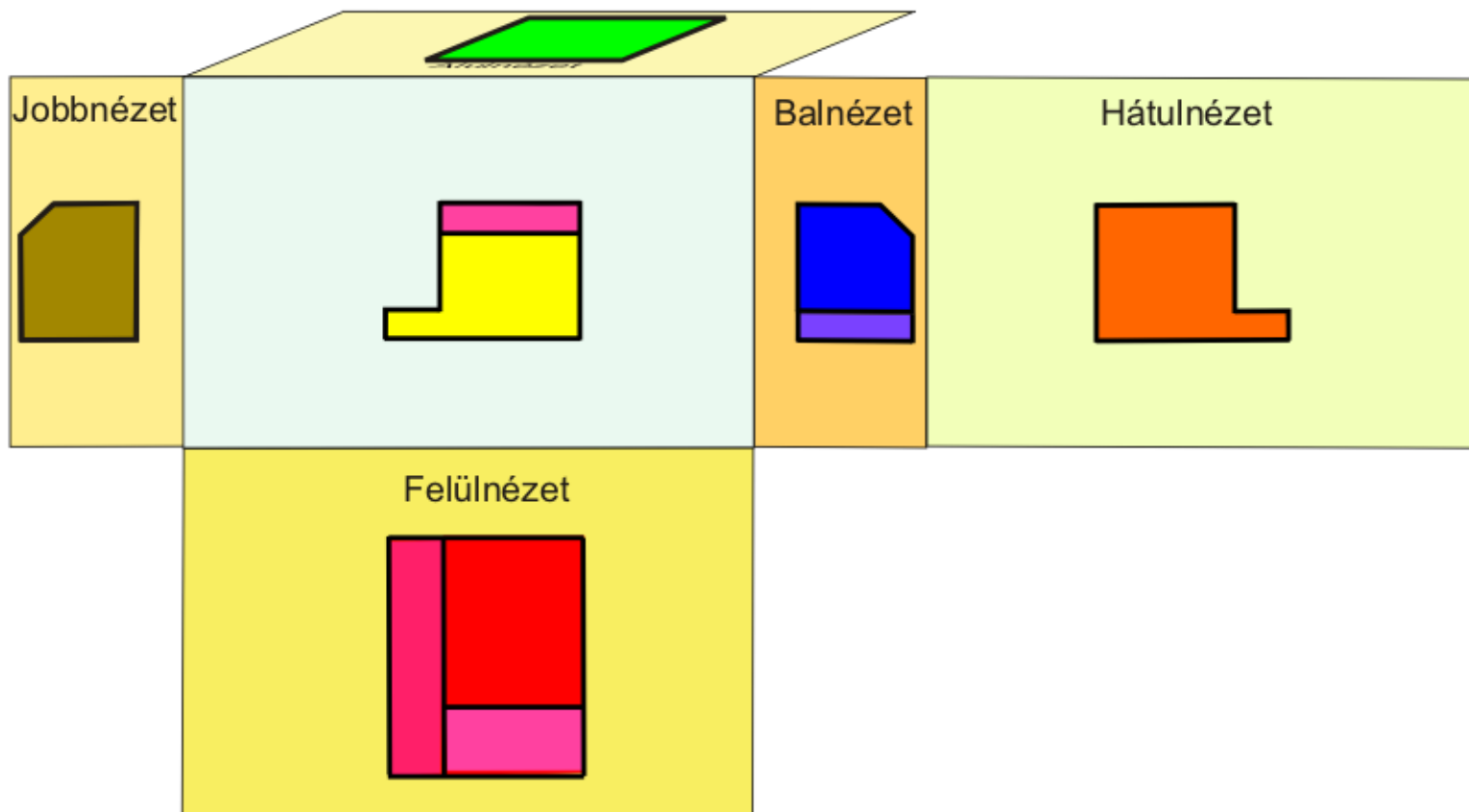

# A „doboz” kiterítése

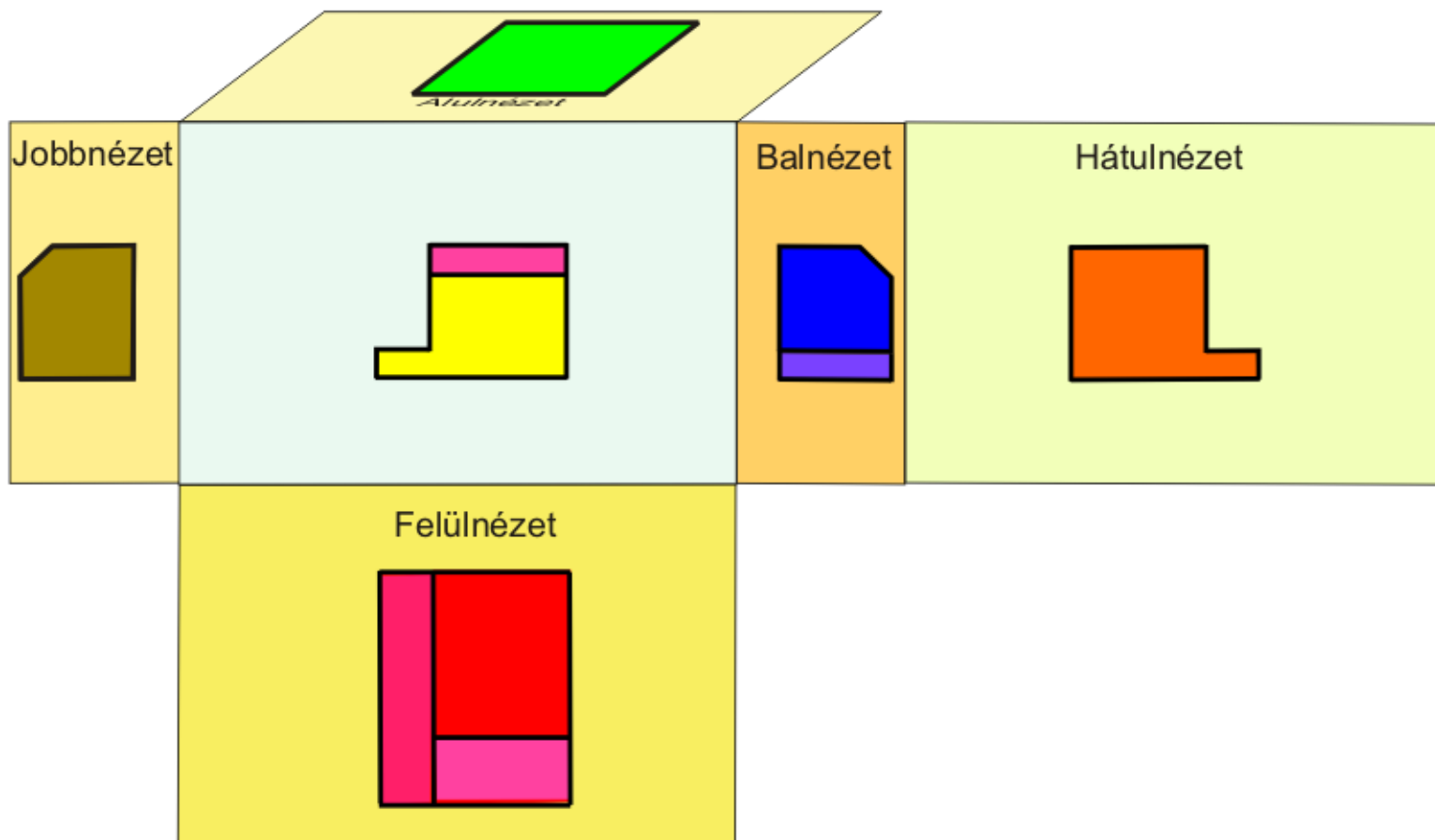

# A „doboz” kiterítése

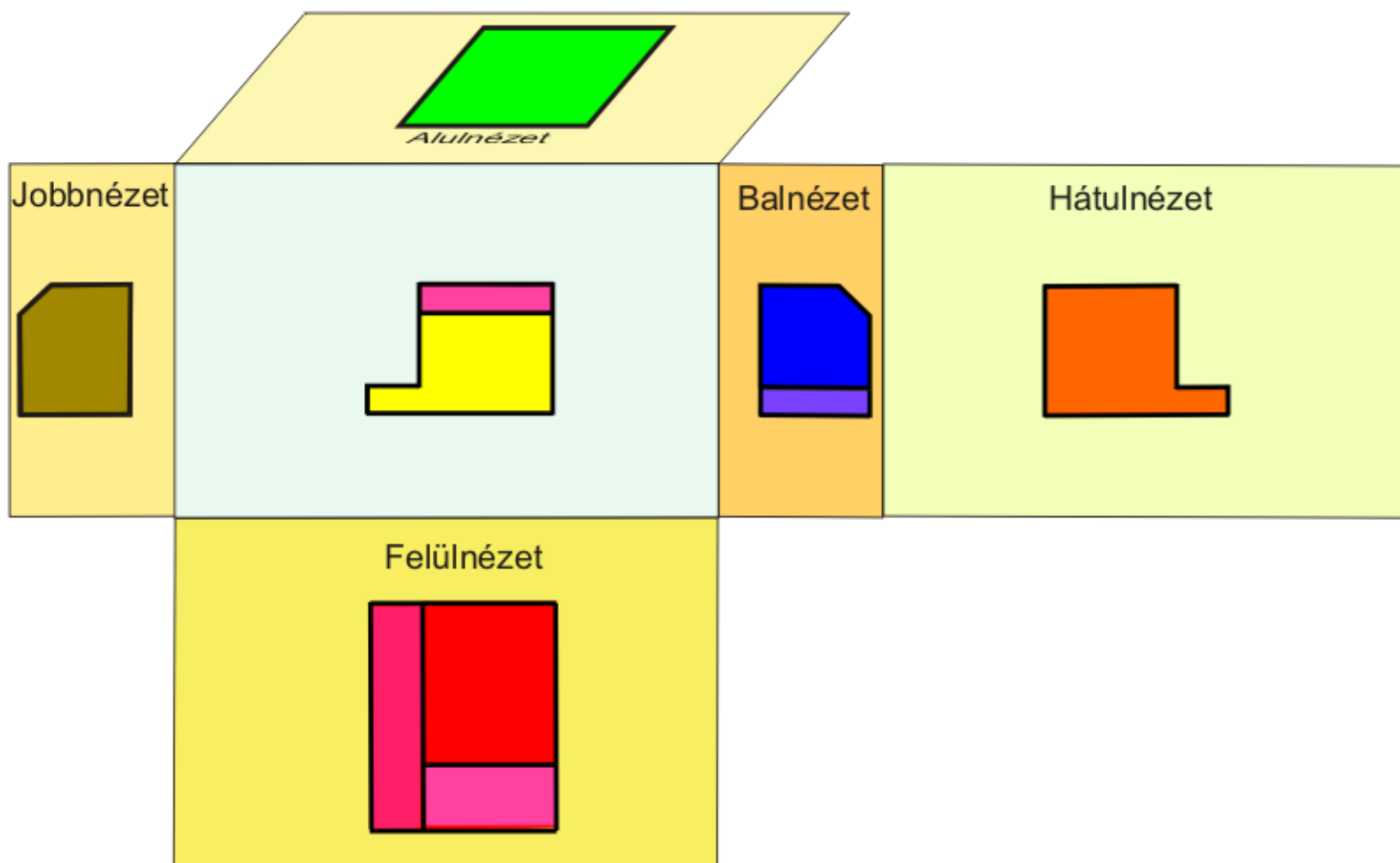



# A „doboz” kiterítése

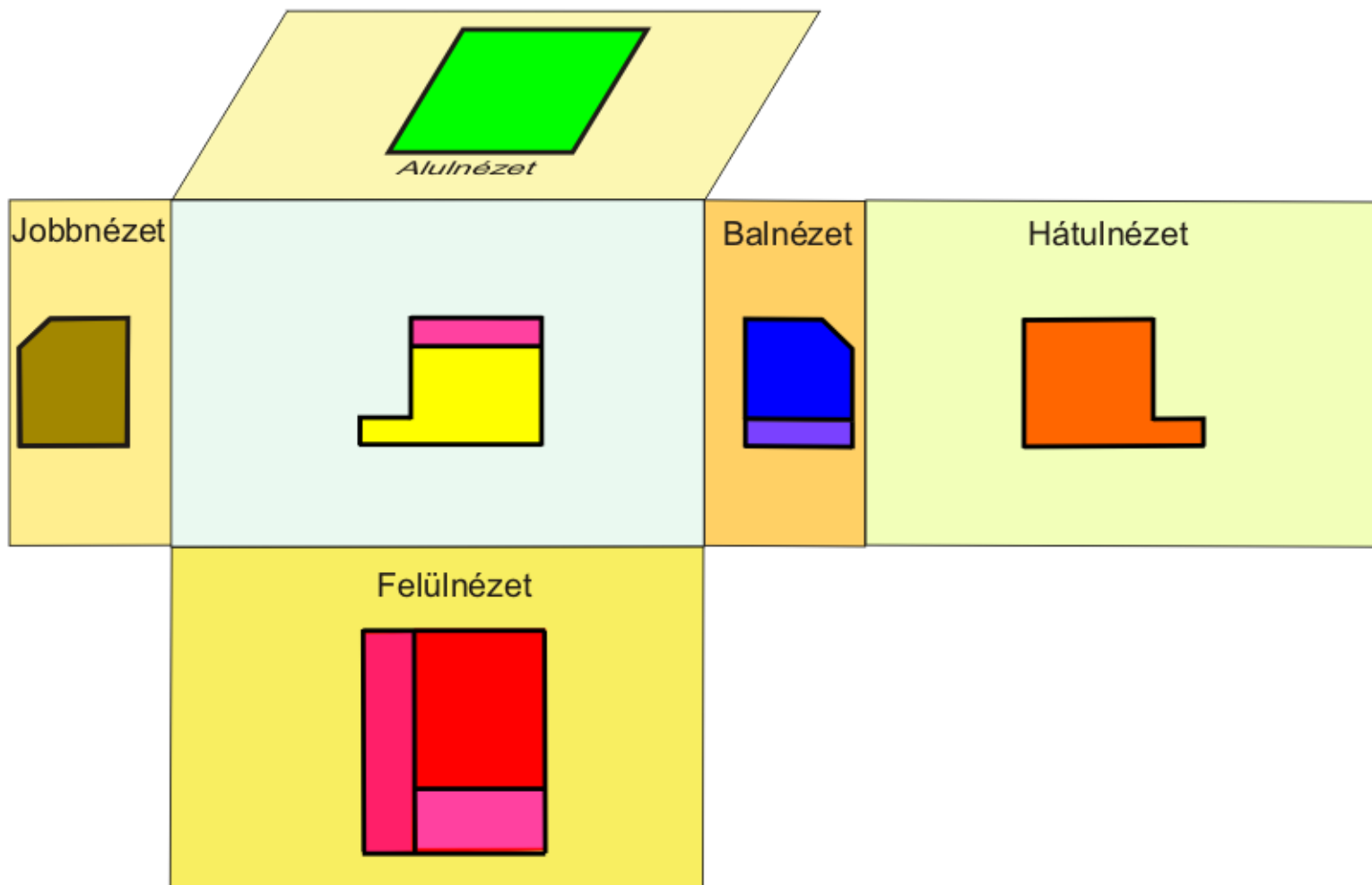

# A „doboz” kiterítése

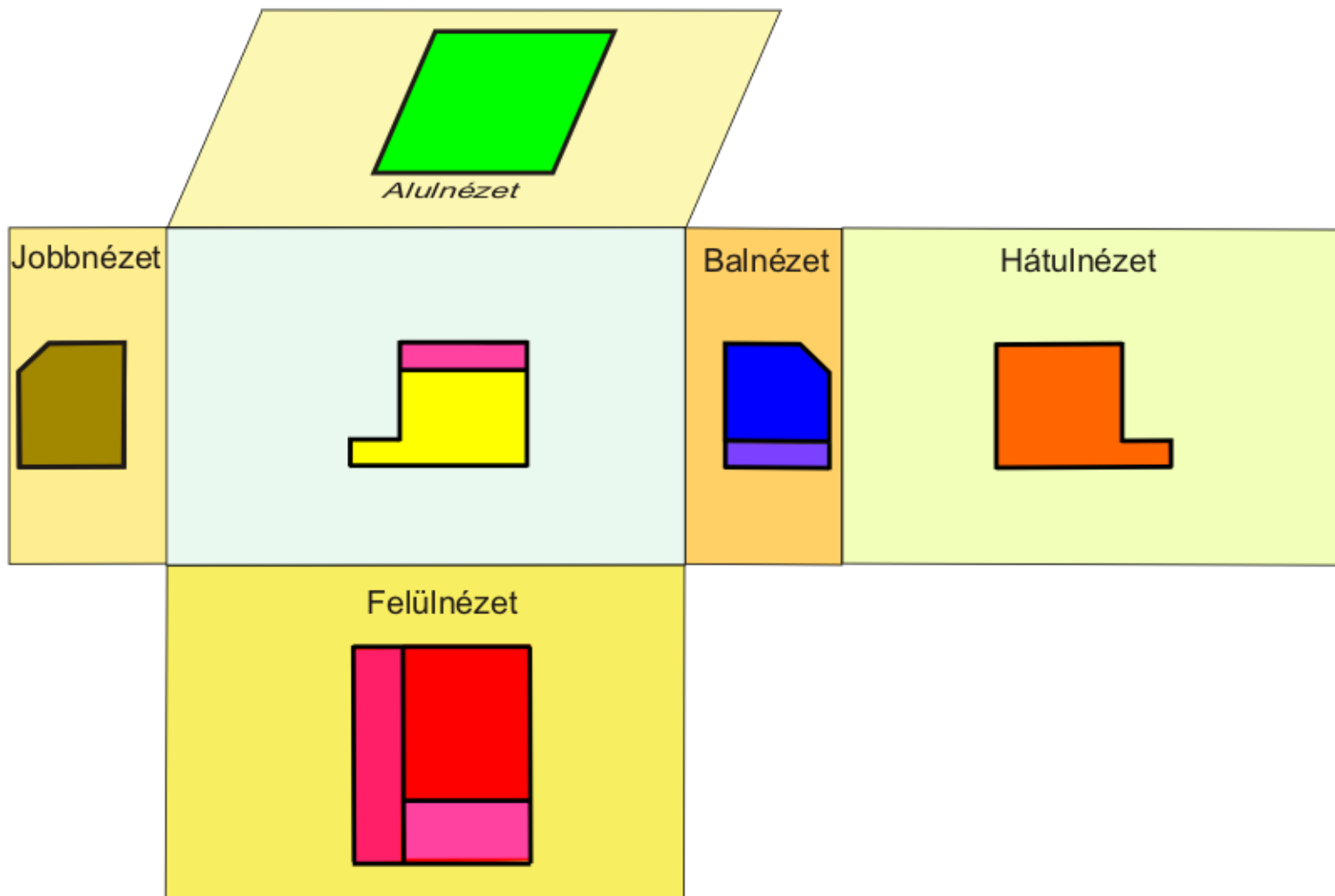

# A „doboz” kiterítése

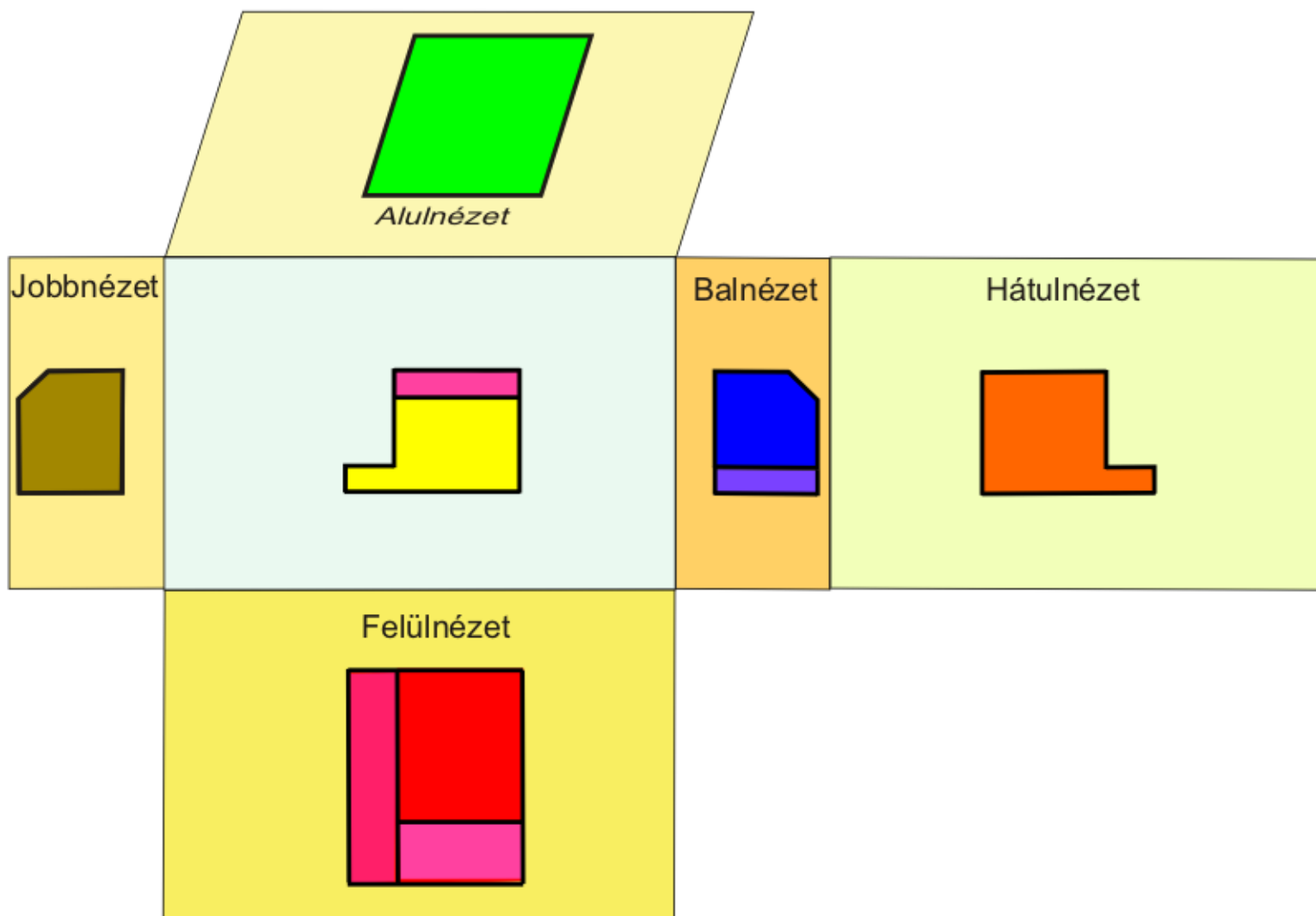

# A „doboz” kiterítése

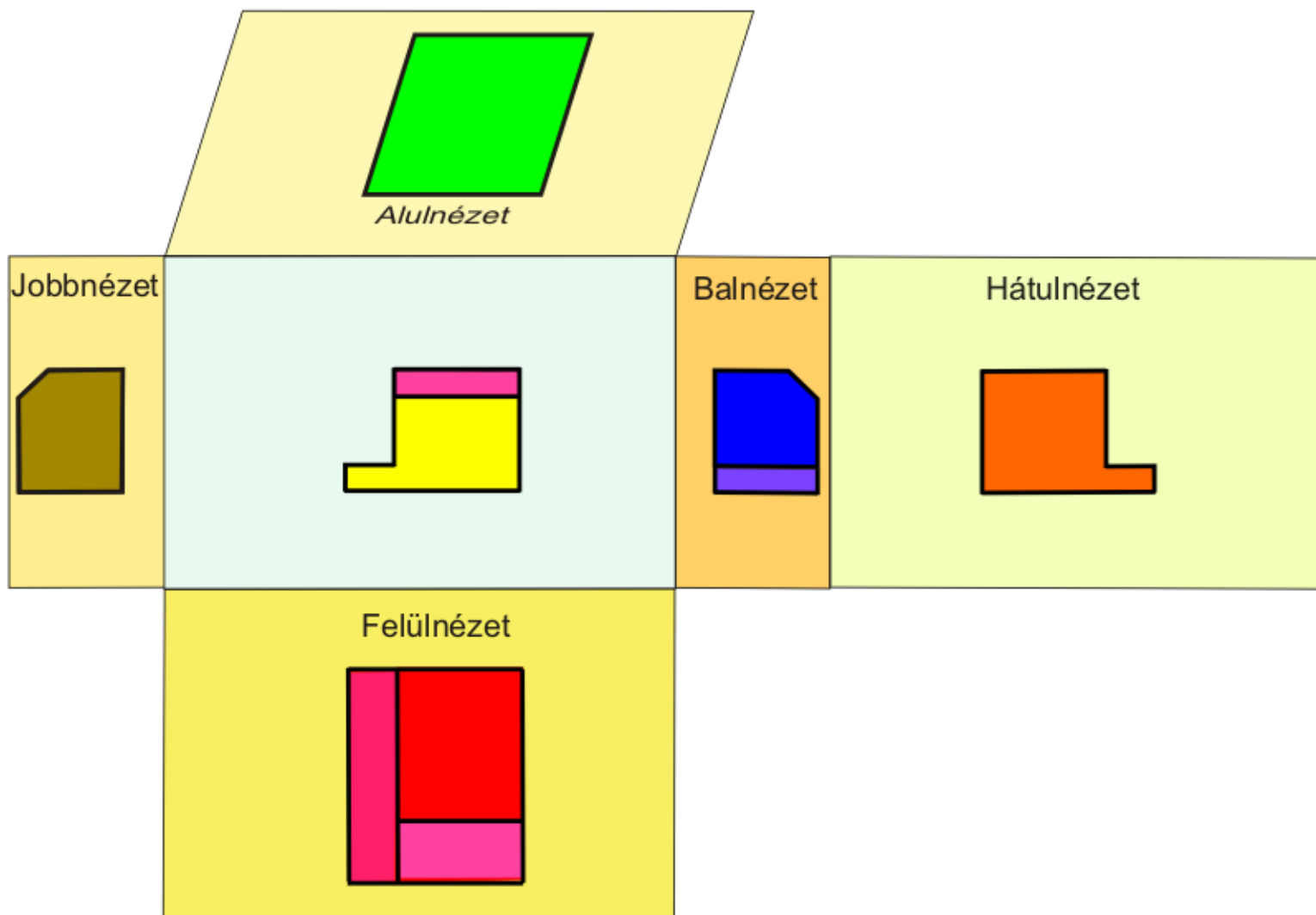

# A „doboz” kiterítése

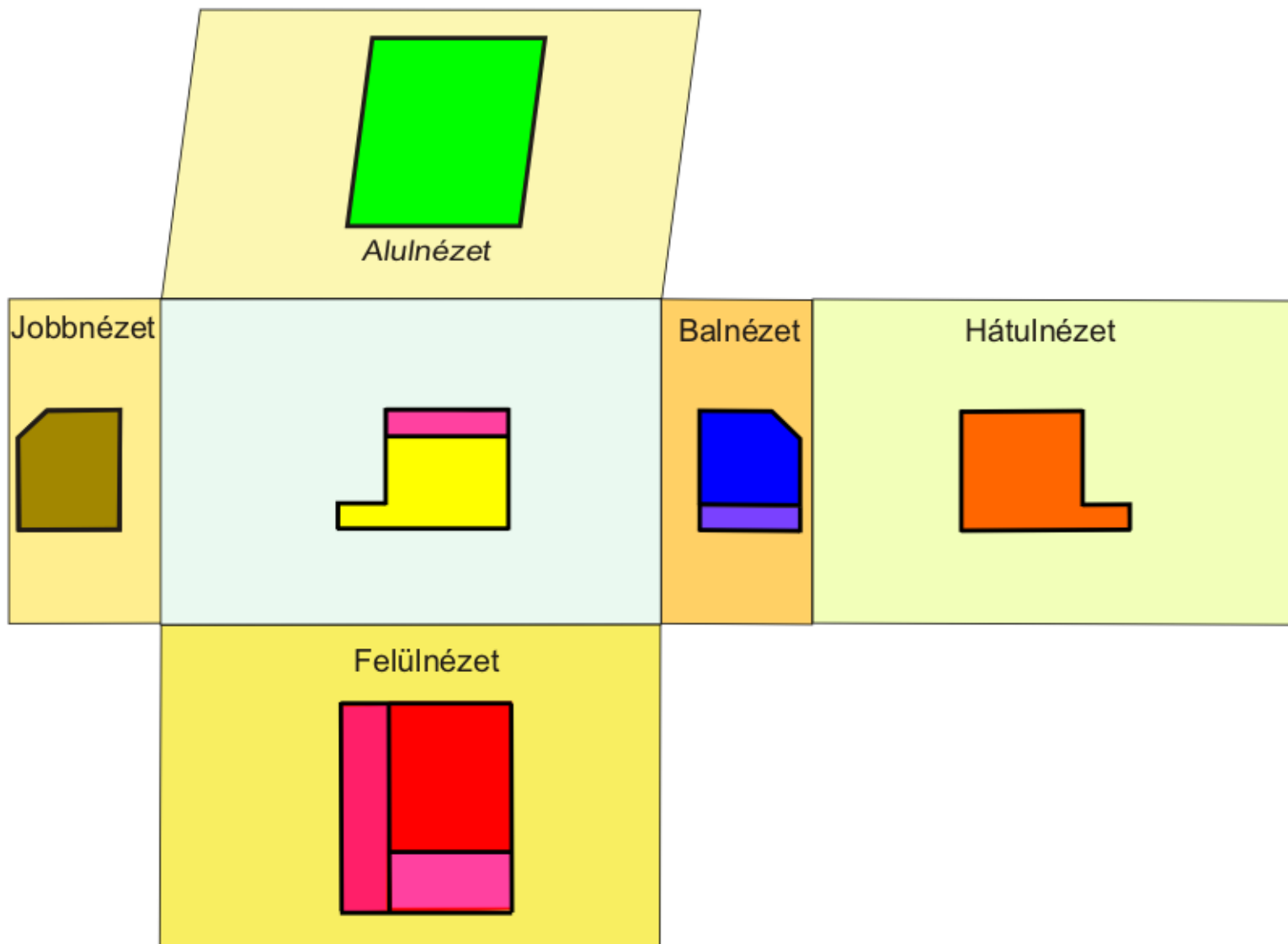

# A „doboz” kiterítése

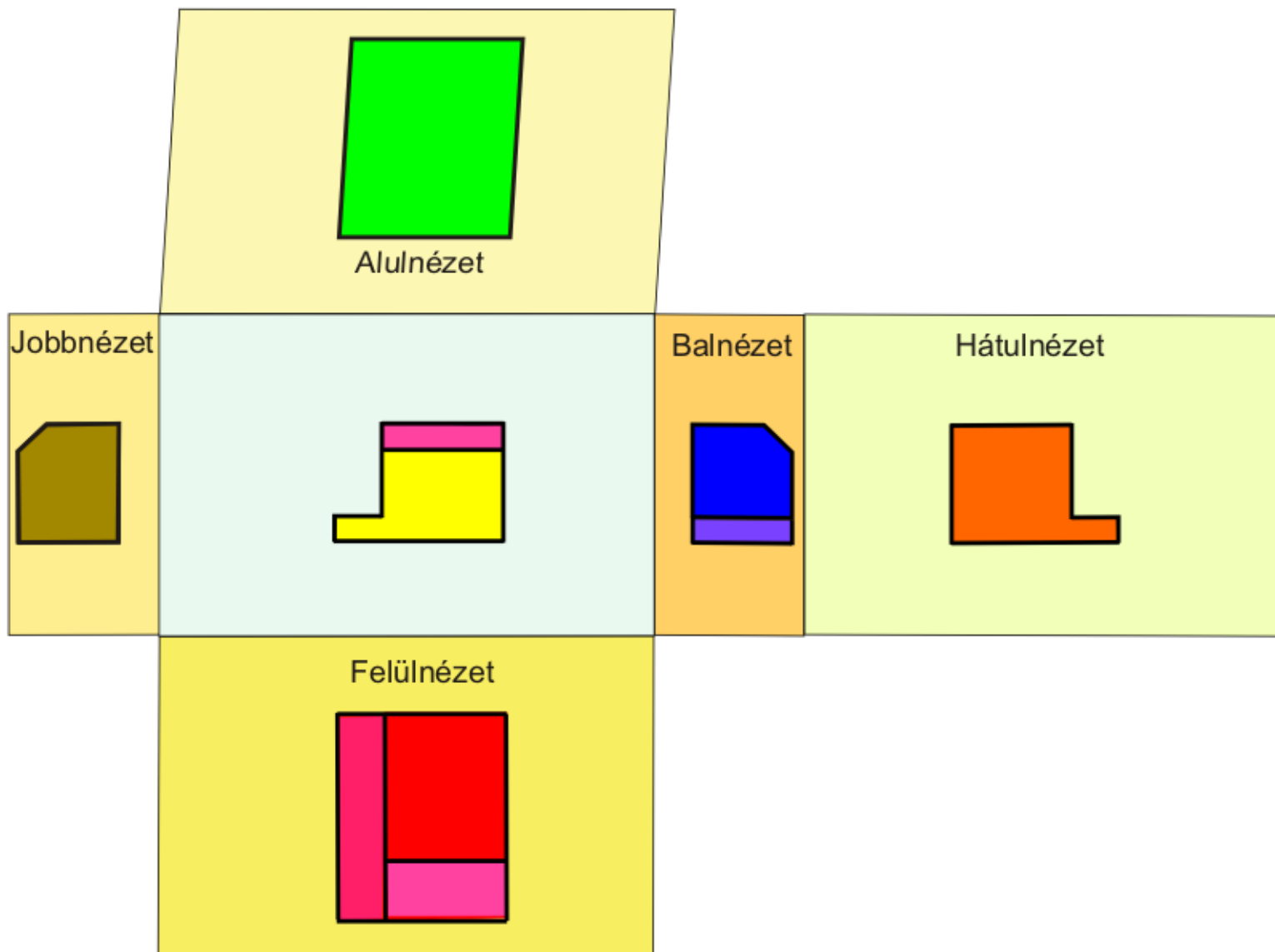

# A „doboz” kiterítése

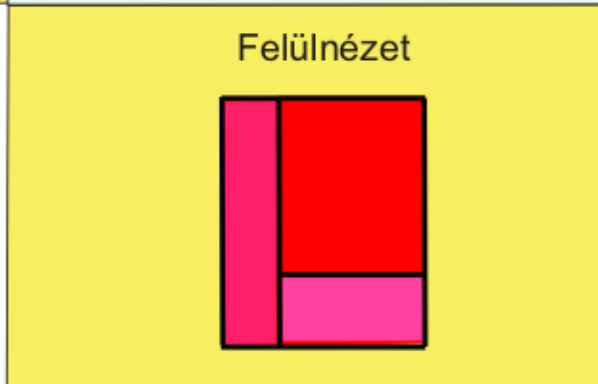
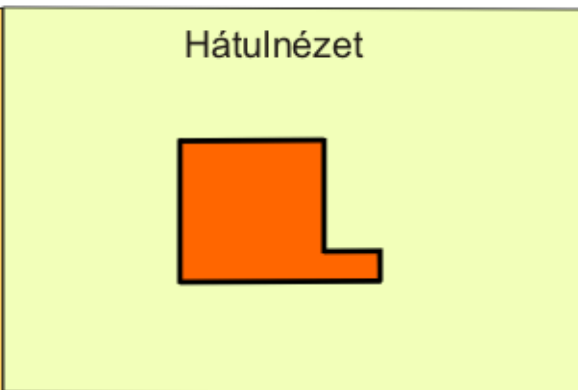
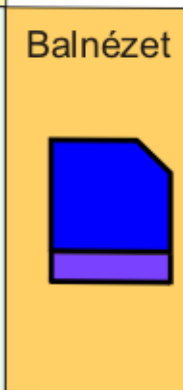
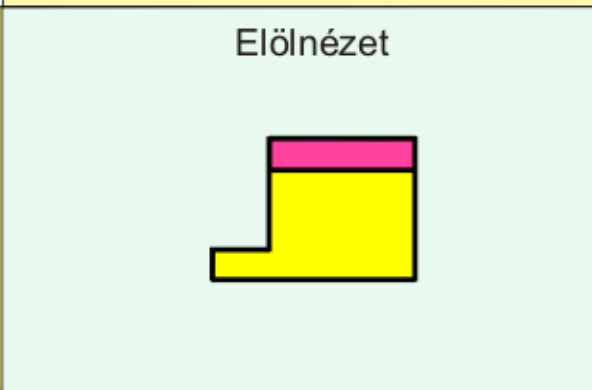
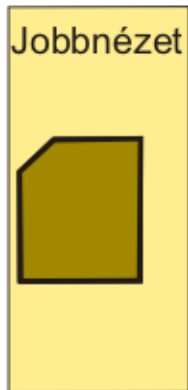
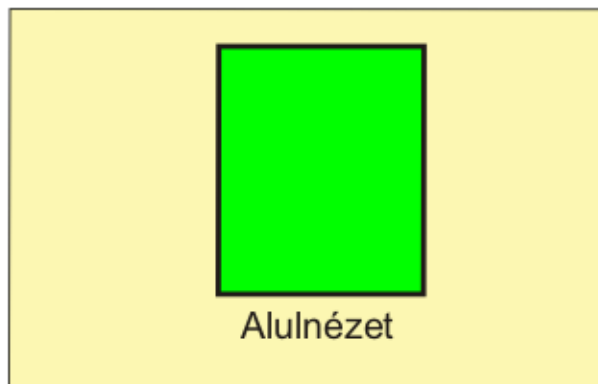

# A kiterített „doboz” a rajzlapon

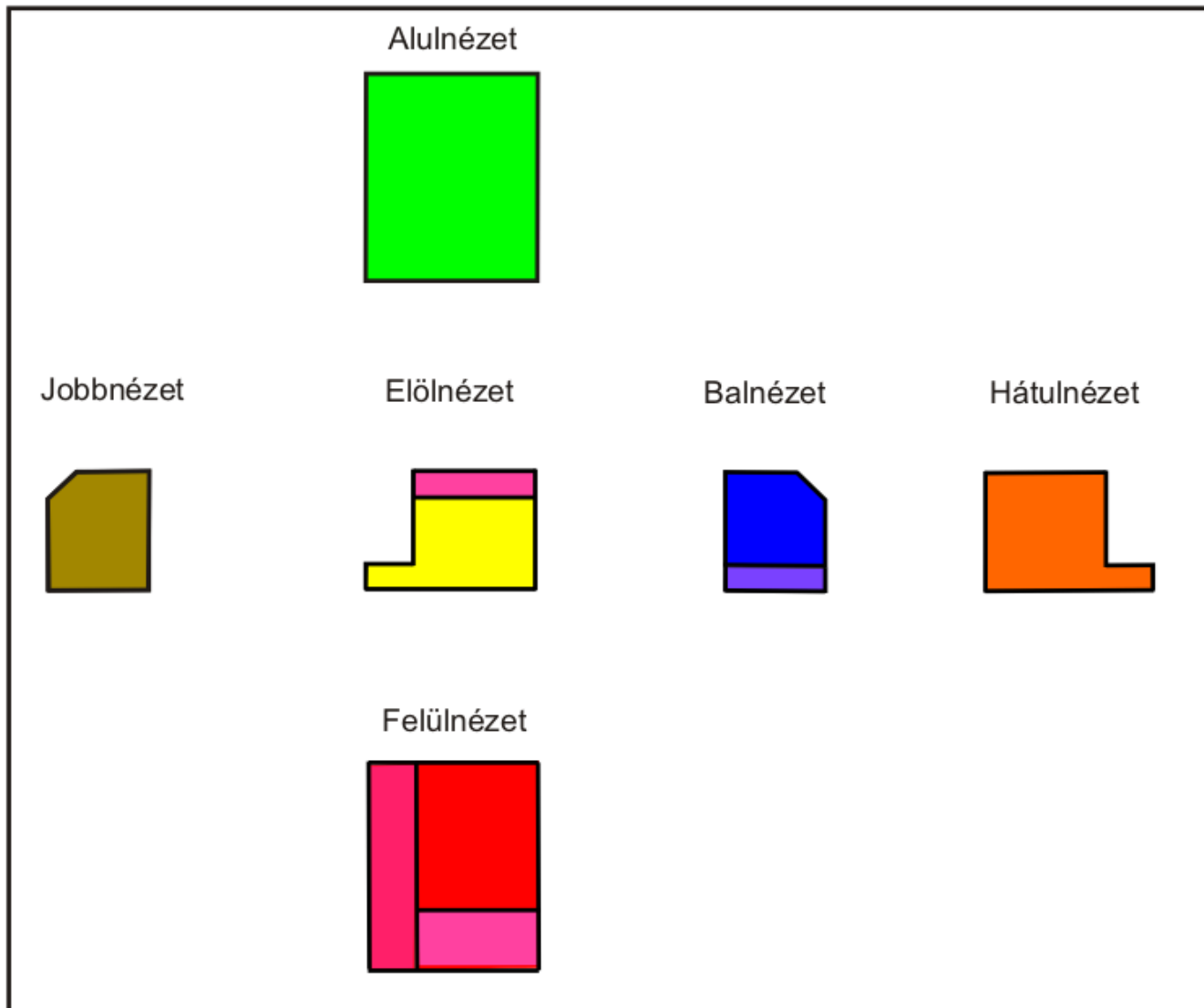



# A vetületek szabványos elhelyezése (rendezett vetületek)

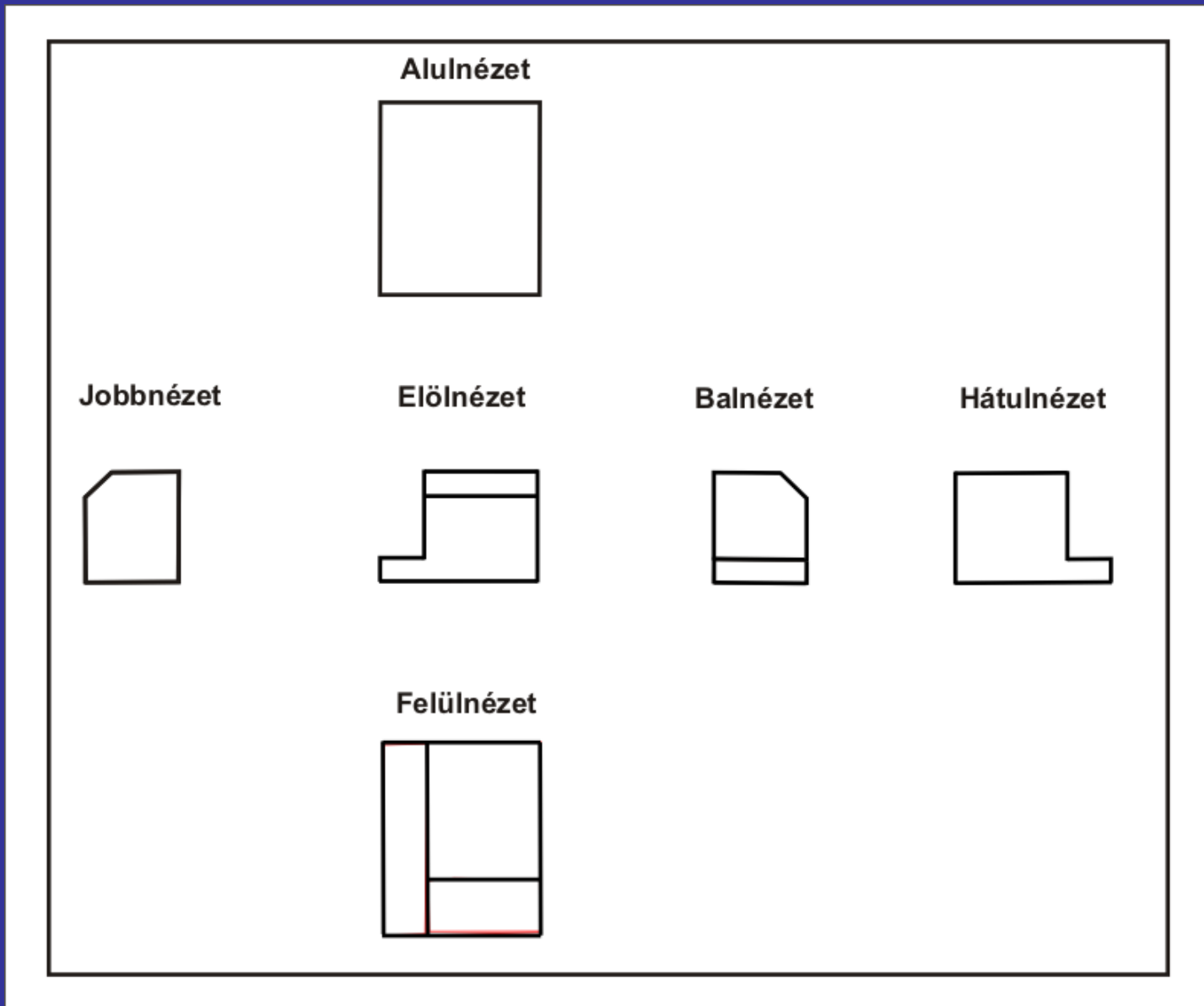

# A vetületképzés szempontjai

# Az alkatrész beállítása a képsíkokhoz képest

- Lehetőleg az előlnézet adja a legtöbb információt (a rajz főnézete általában az alkatrész előlnézete)
- Az alkatrész lehetőleg a végleges beépítési helyzetben legyen
- Az alkatrész szimmetriatengelyei a képsíkokkal párhuzamosak vagy rájuk merőlegesek legyenek
- Az alkatrész sík felületei a képsíkokkal párhuzamosak vagy rájuk merőlegesek legyenek

## A szükséges vetületek száma

- Maximálisan annyi vetület kell, amennyi az alkatrész egyértelmű ábrázolásához éppen szükséges
- Minél kevesebb, annál jobb

**NÉZETEK**

# A nézetkészítés célja

az alkatrész külső formájának egyértelmű megjelenítése

# A NÉZETEK SZÁRMAZTATÁSA

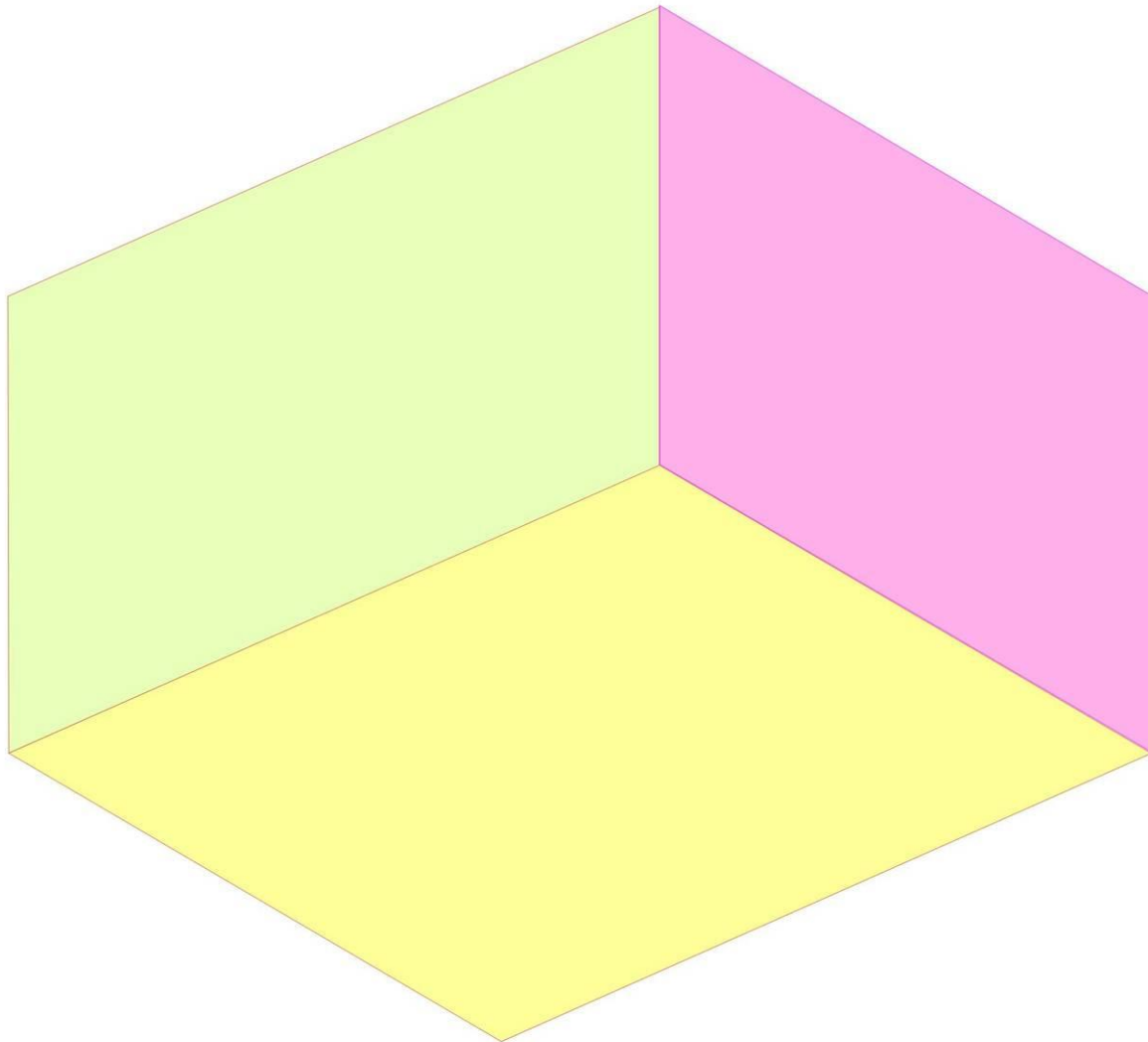

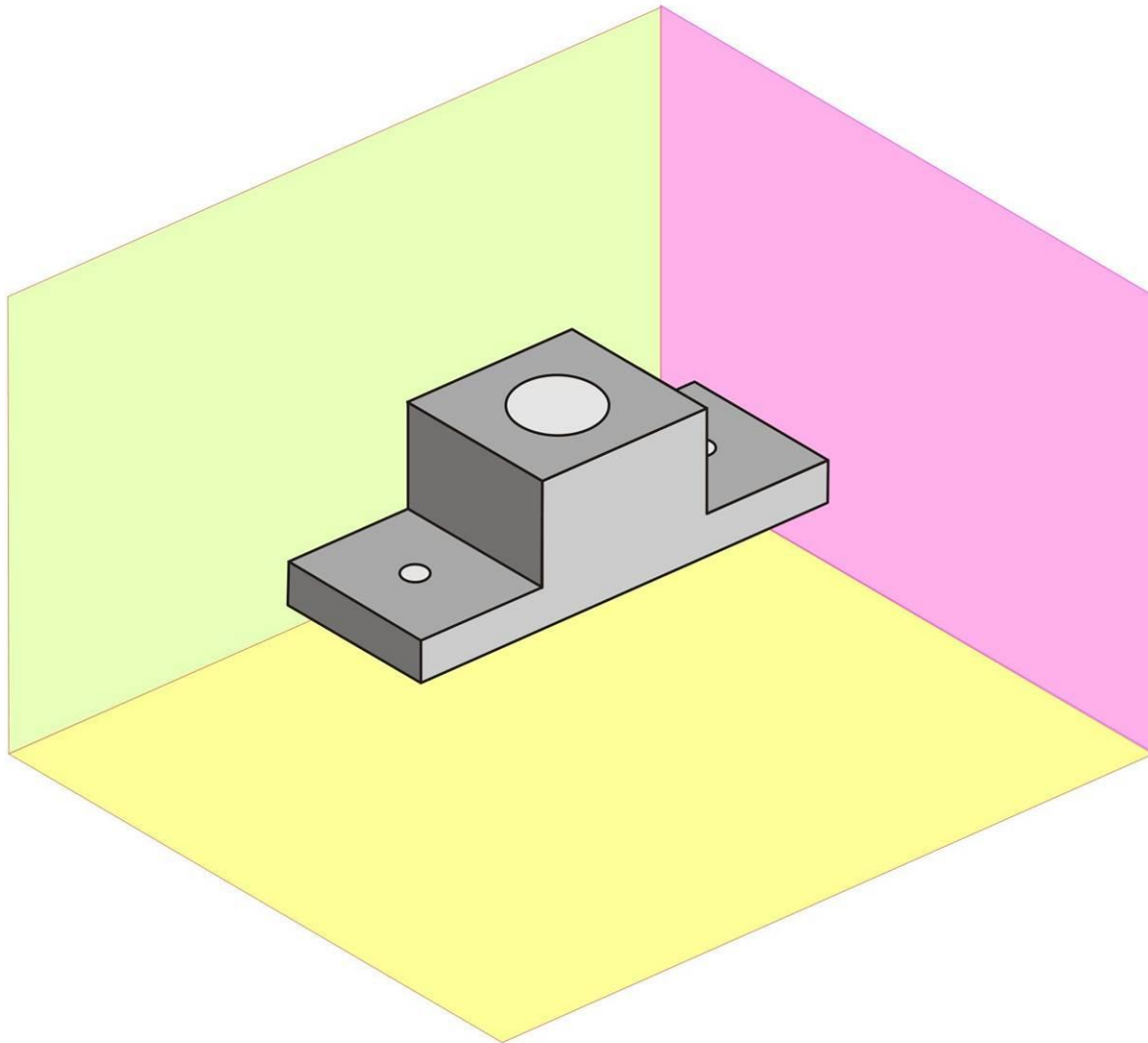



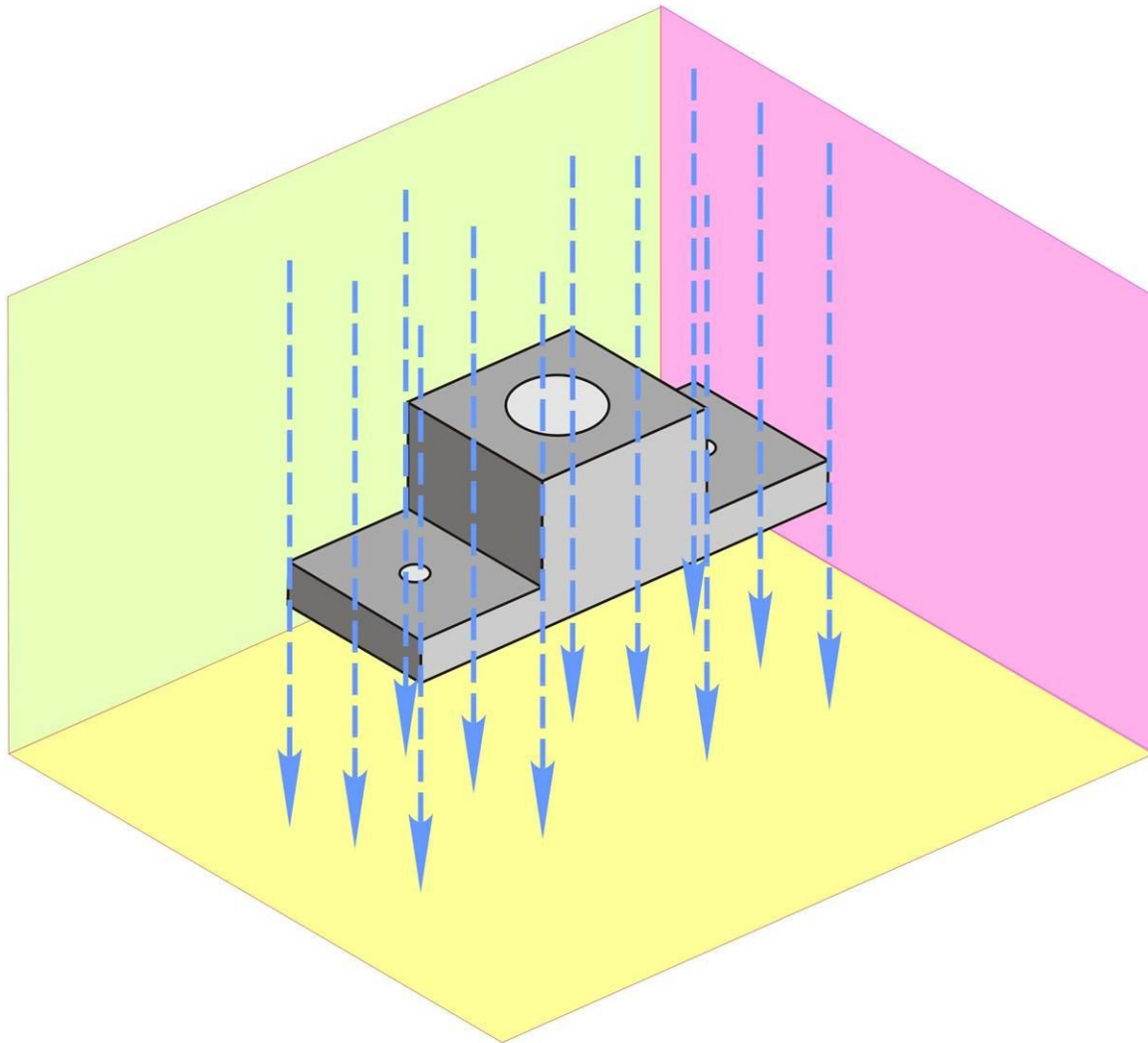

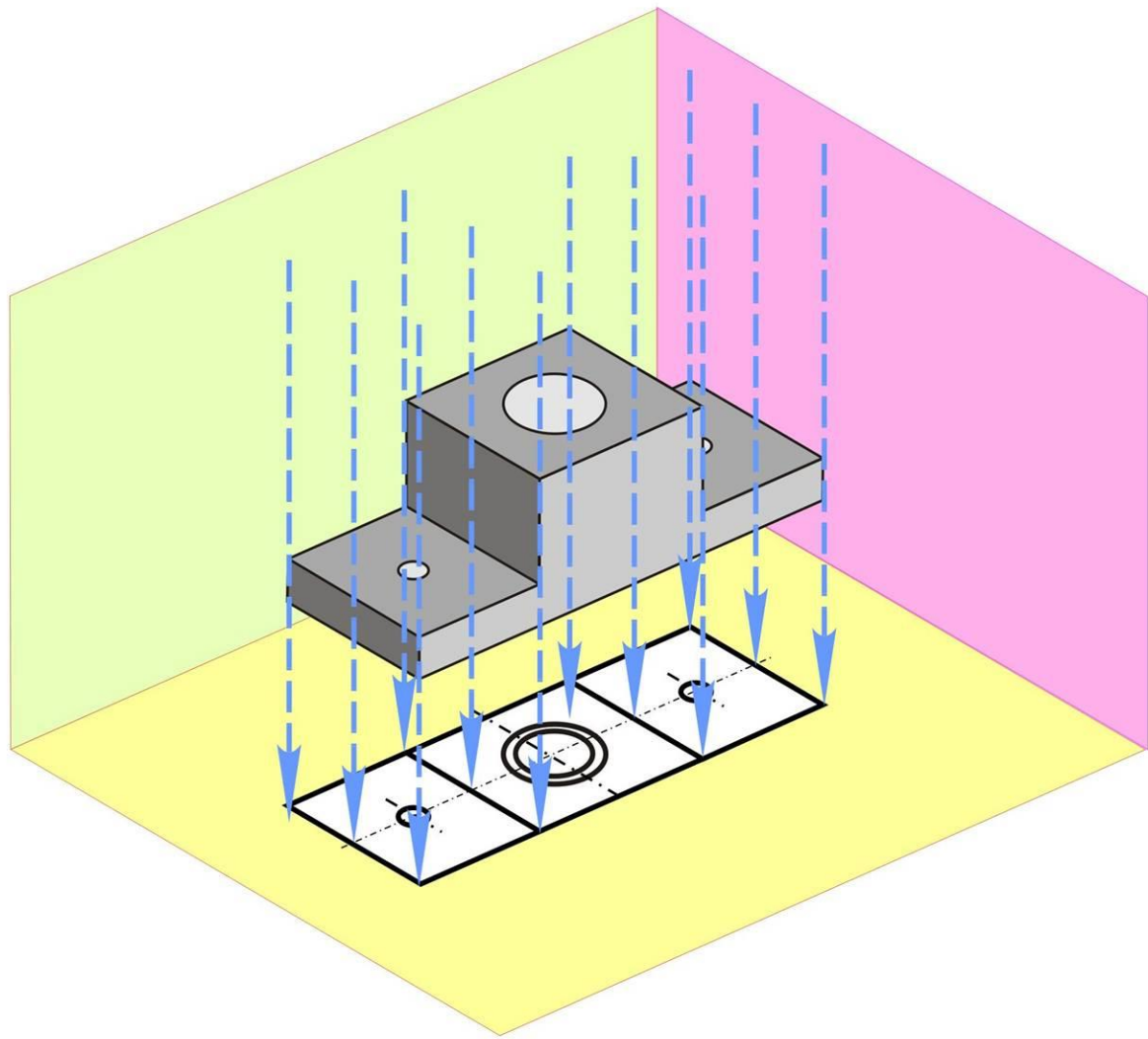

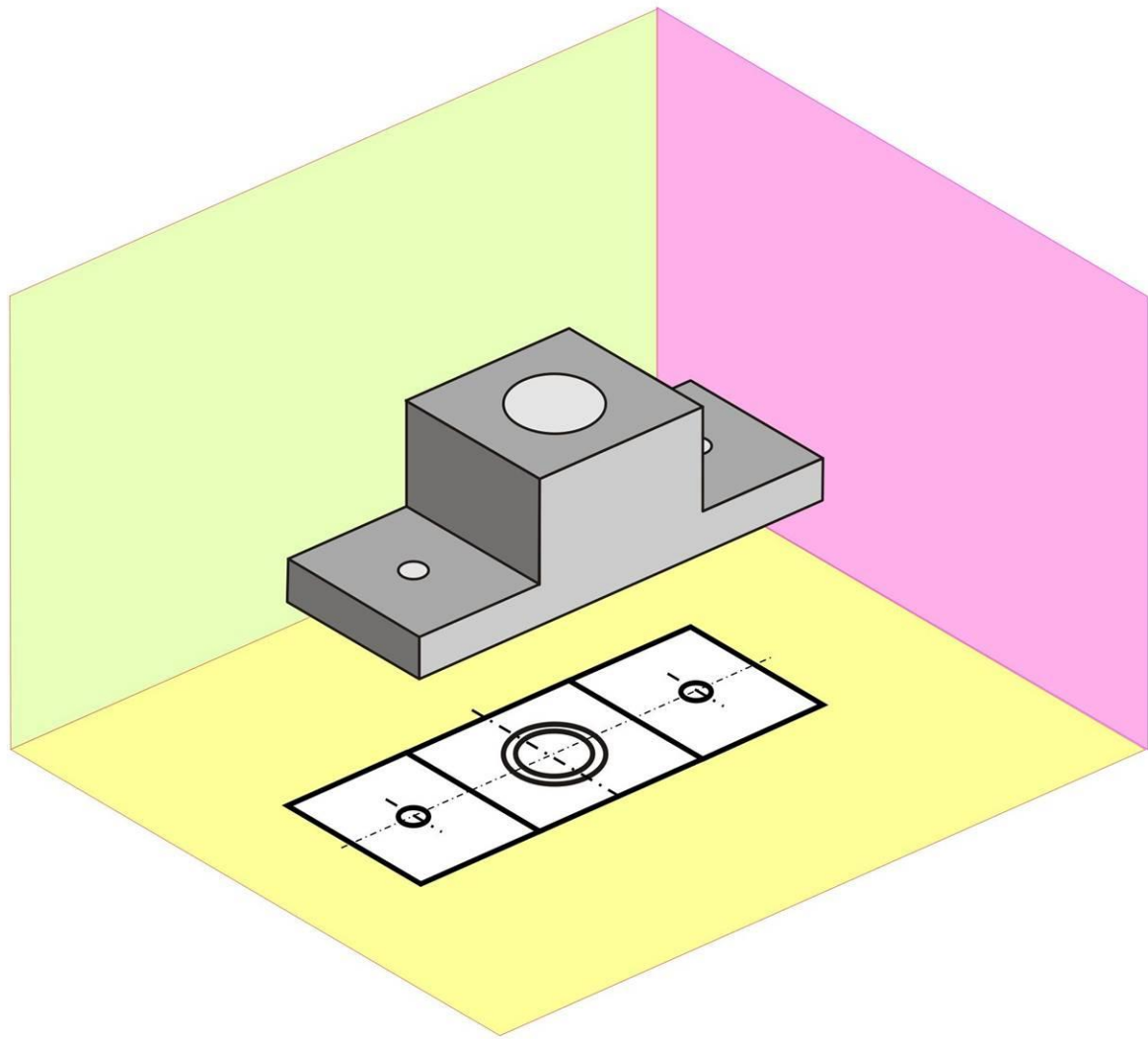

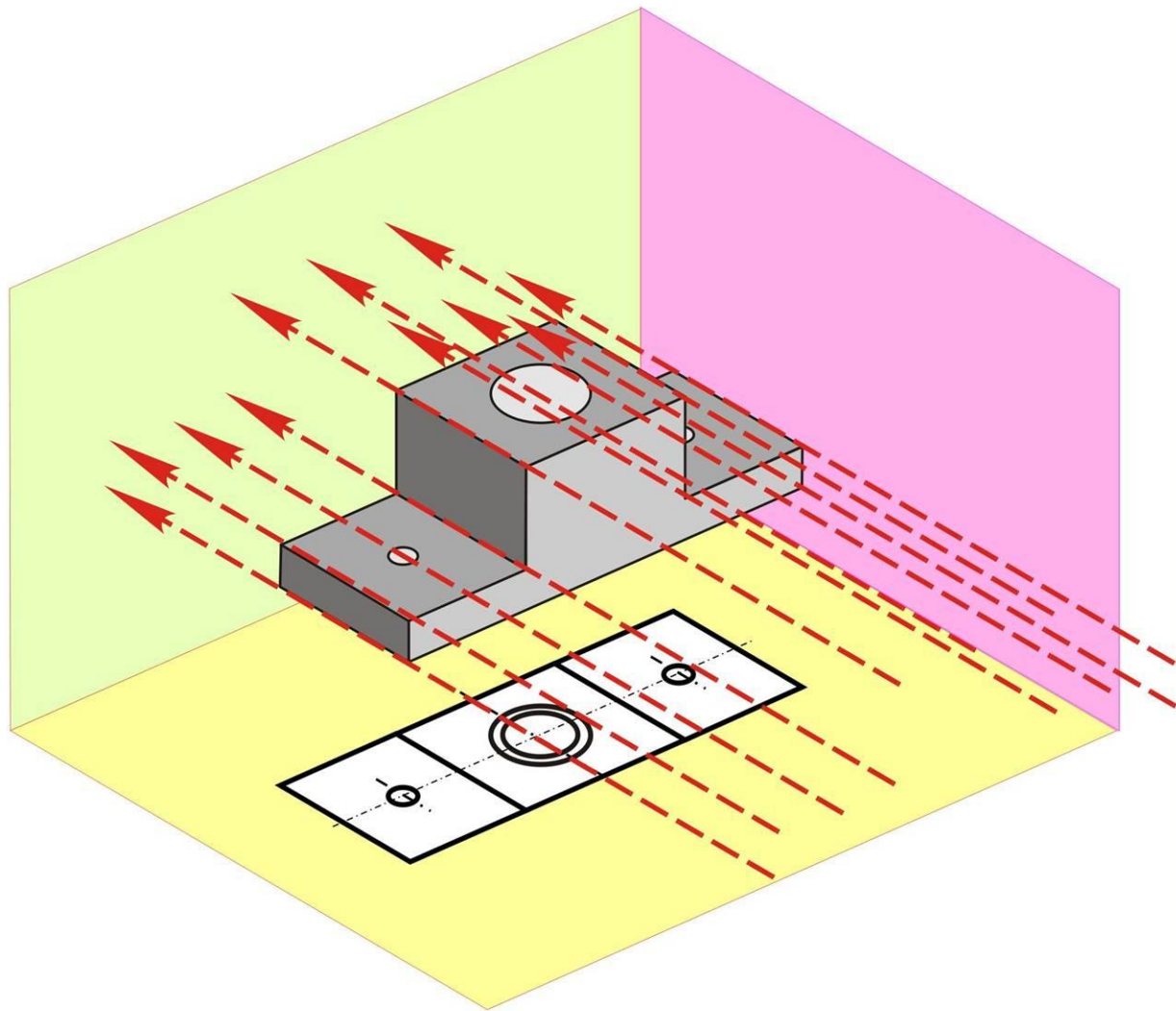

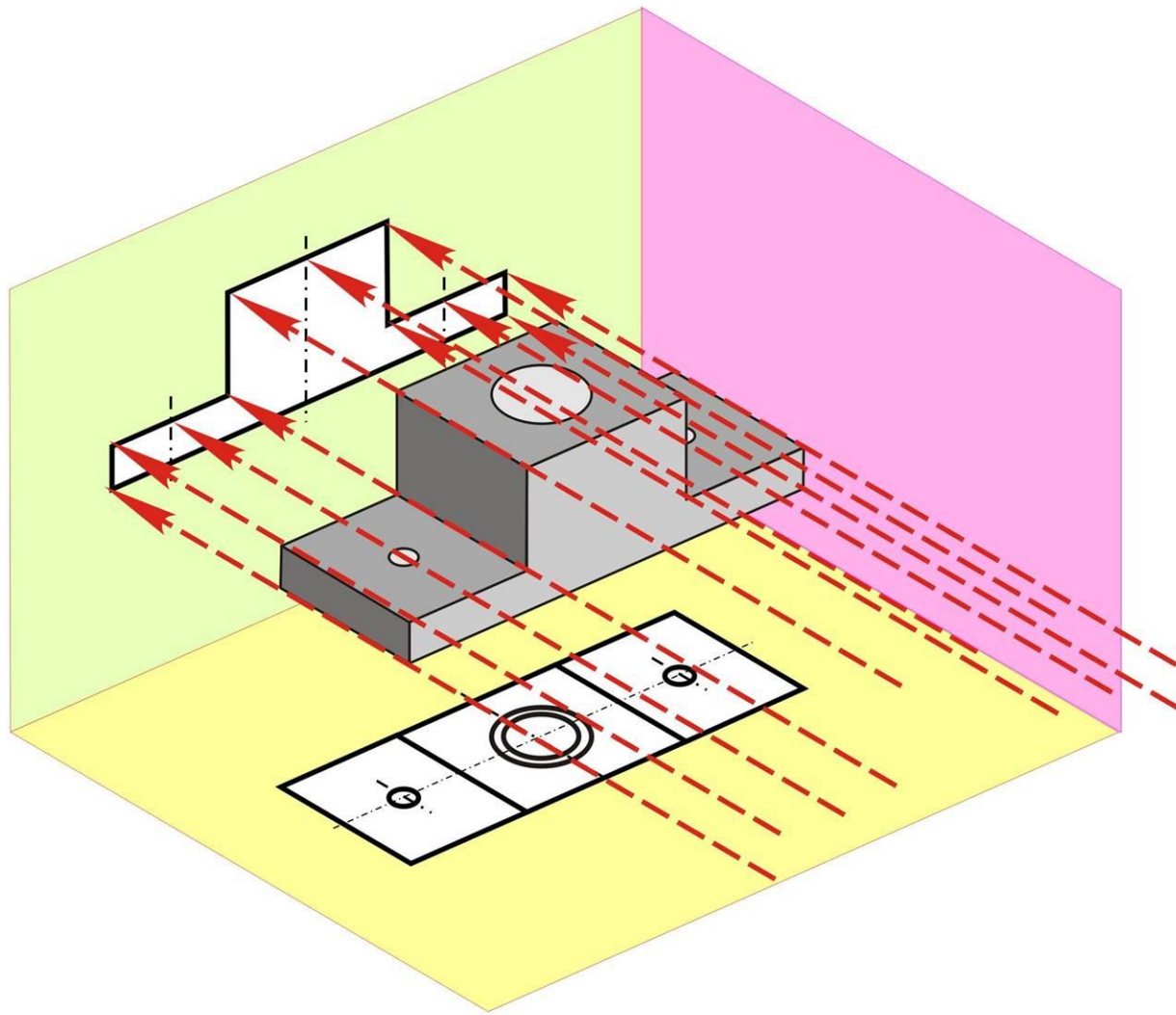

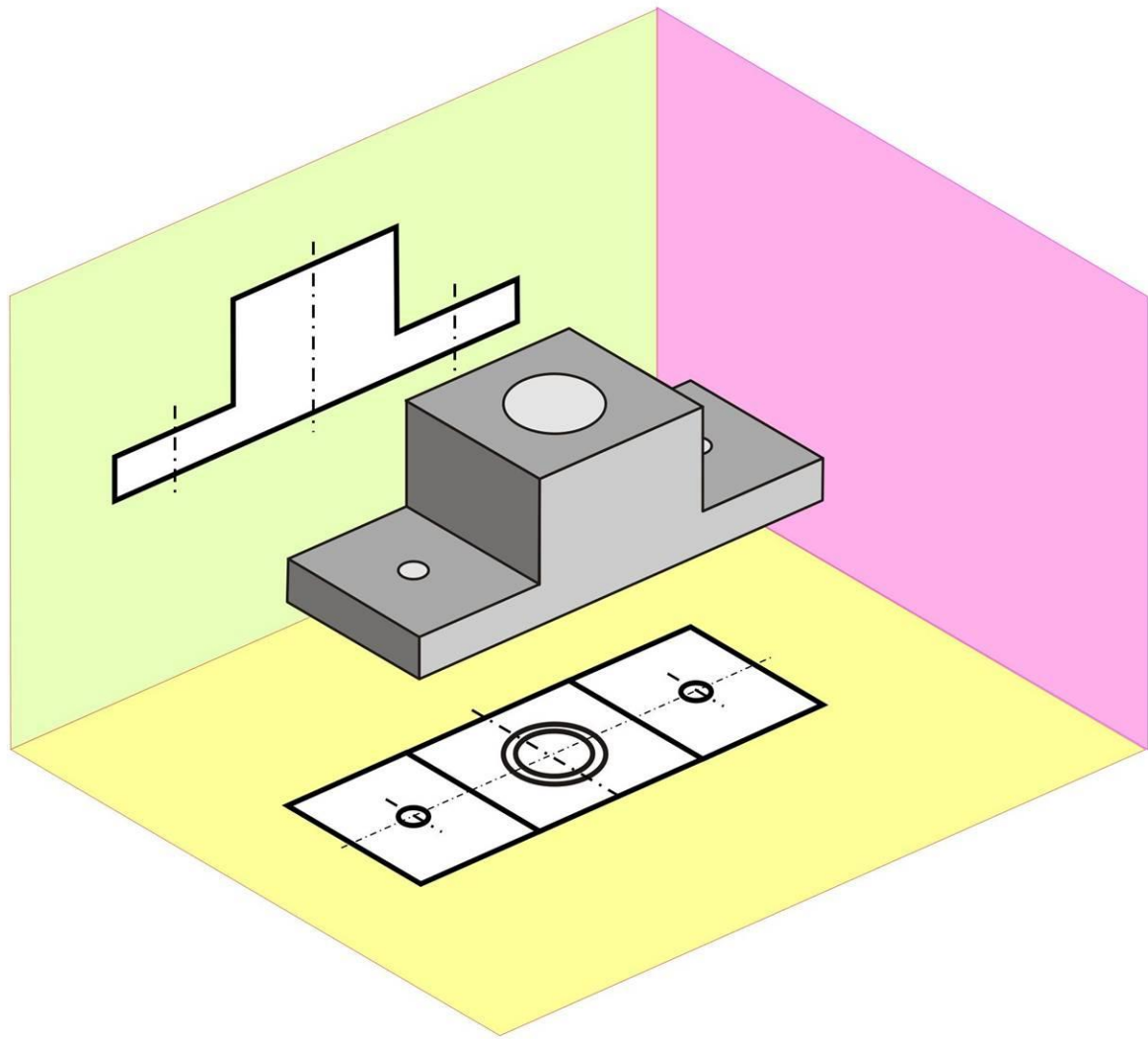

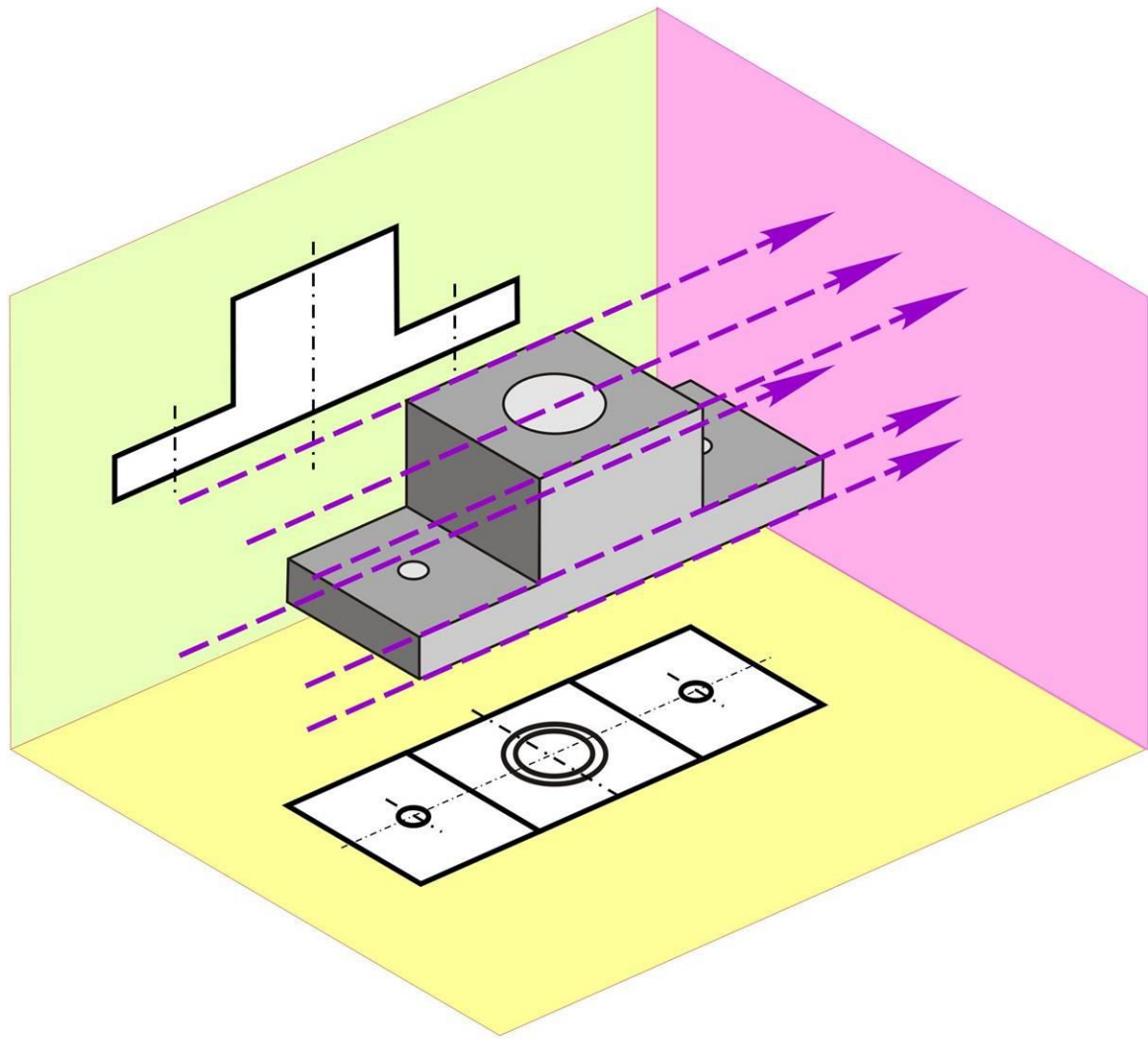

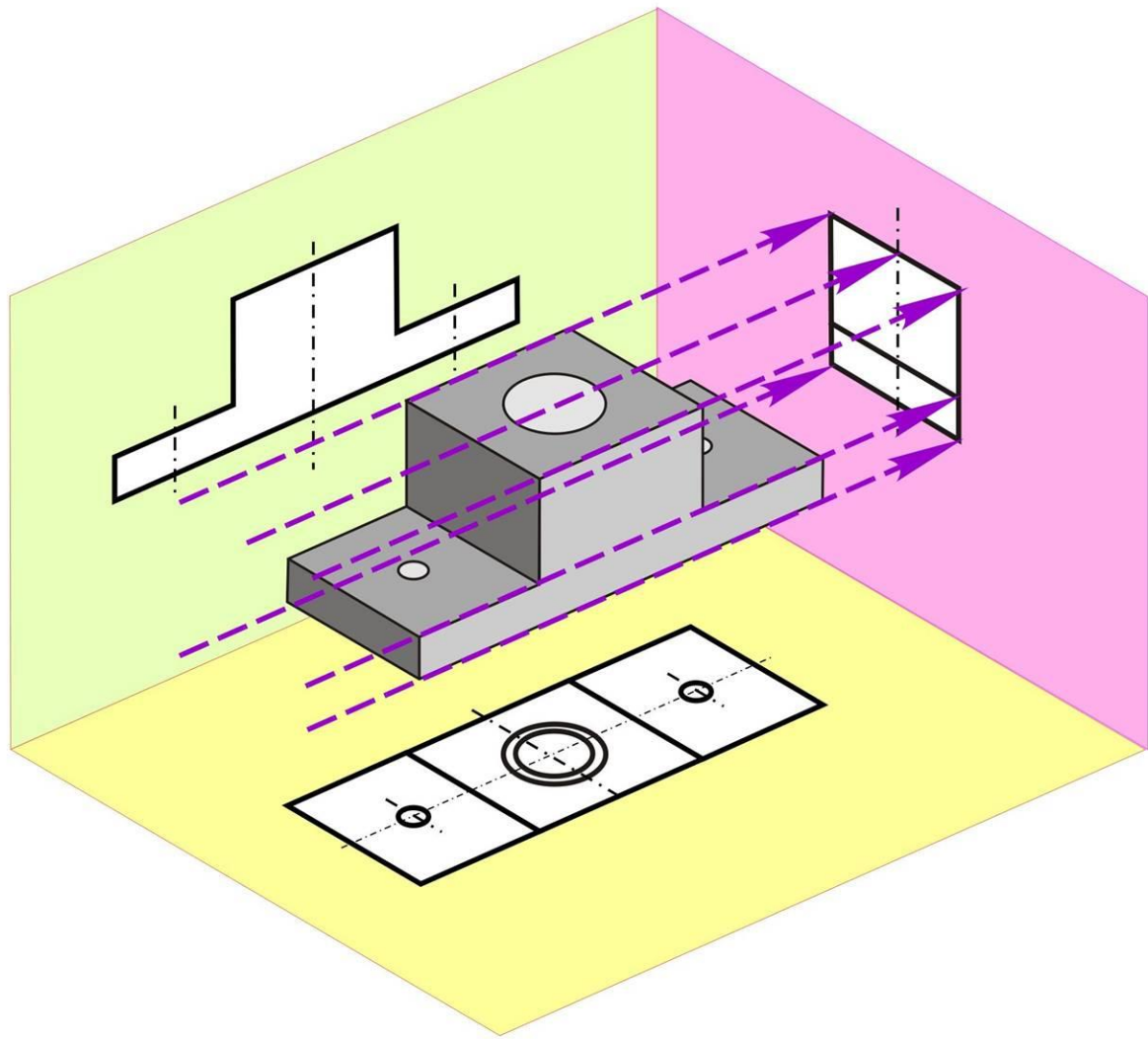



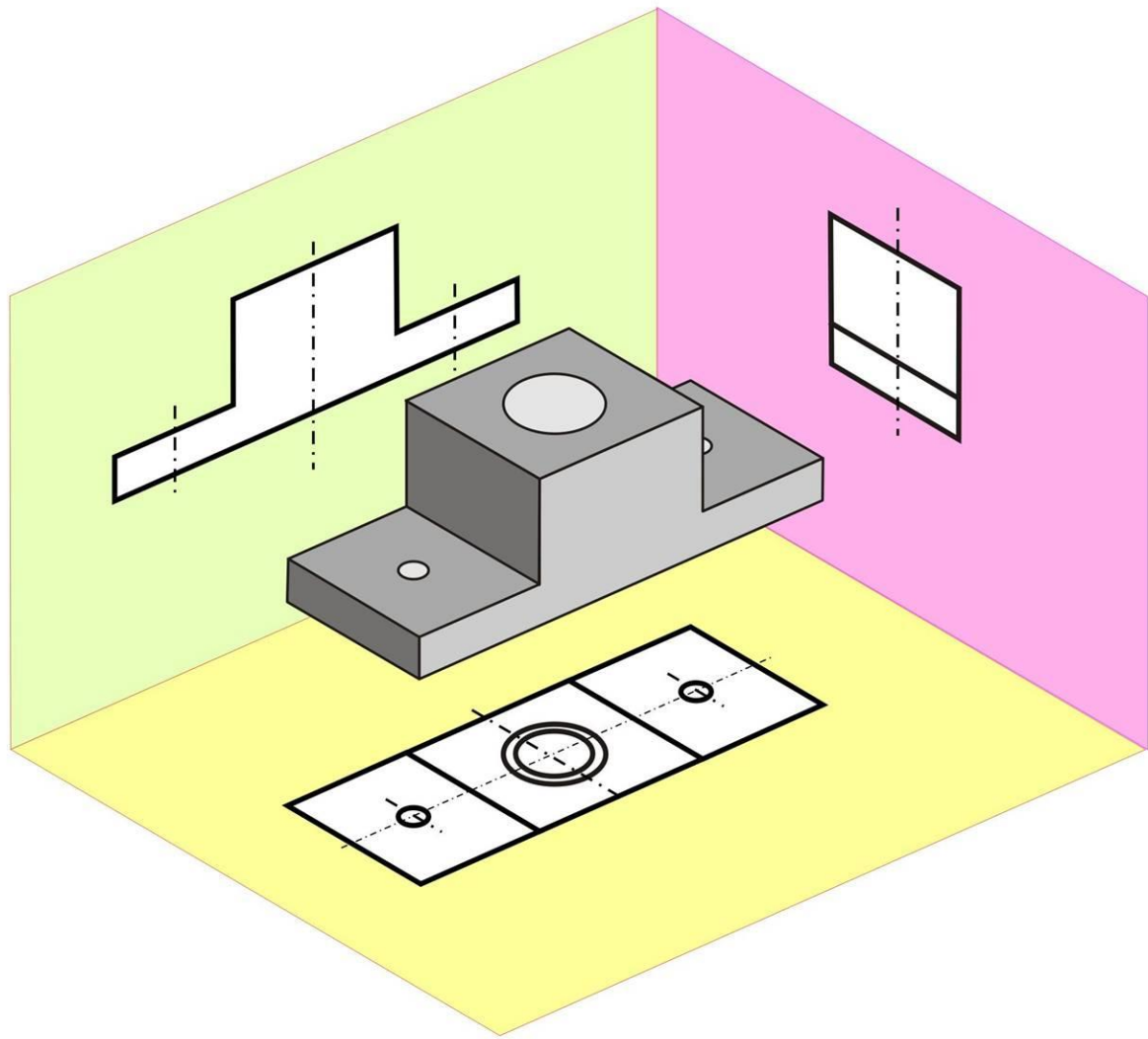

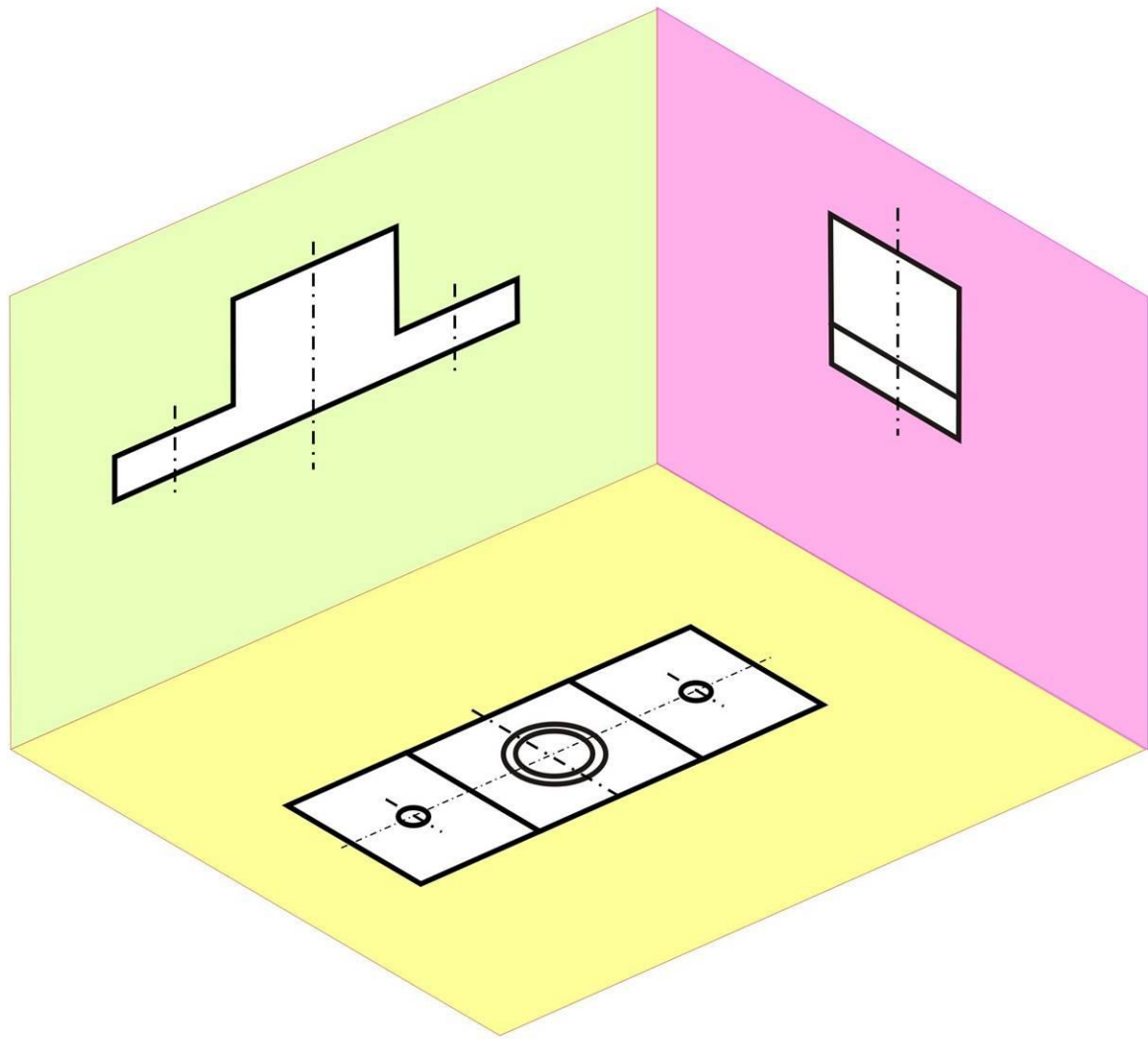

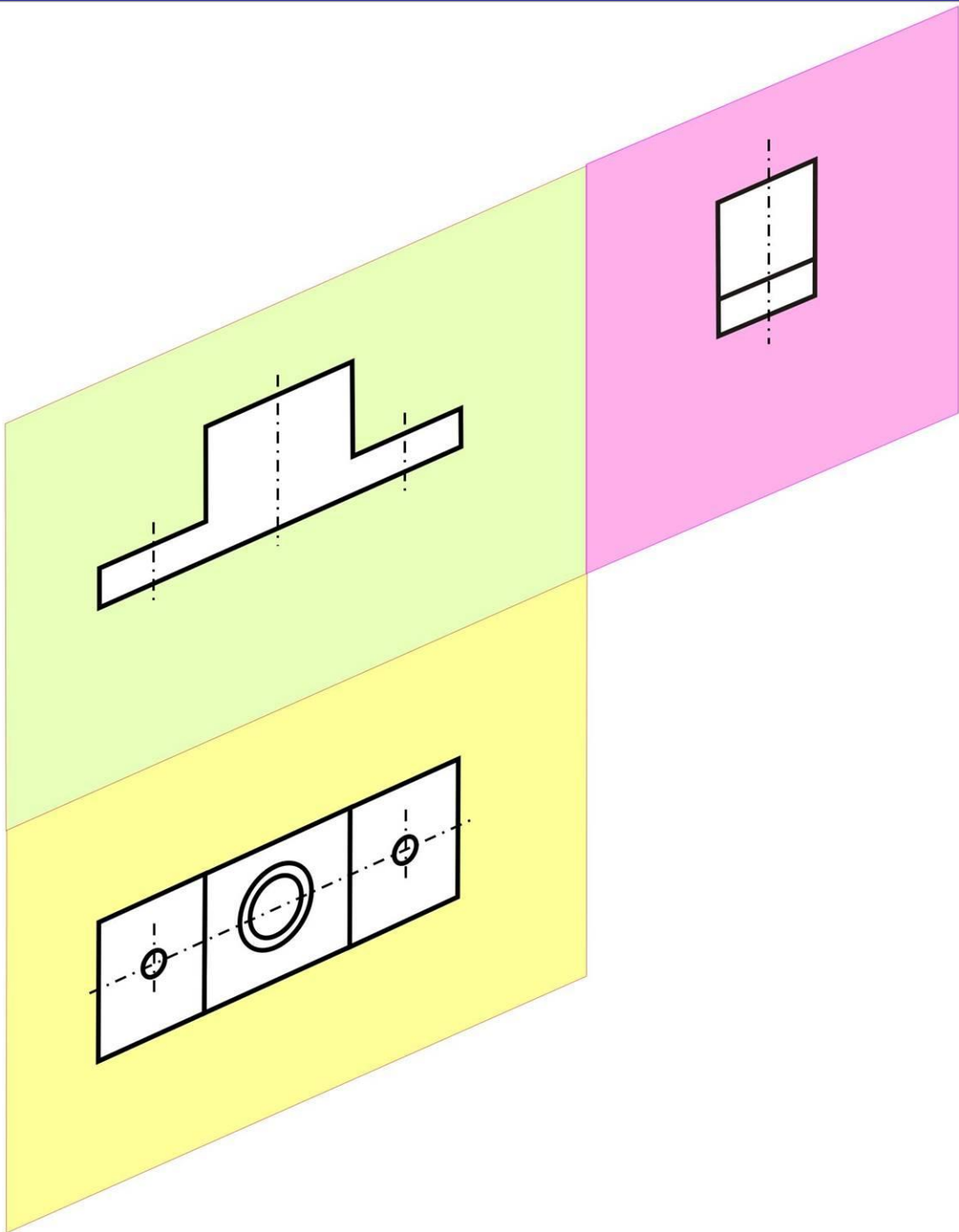

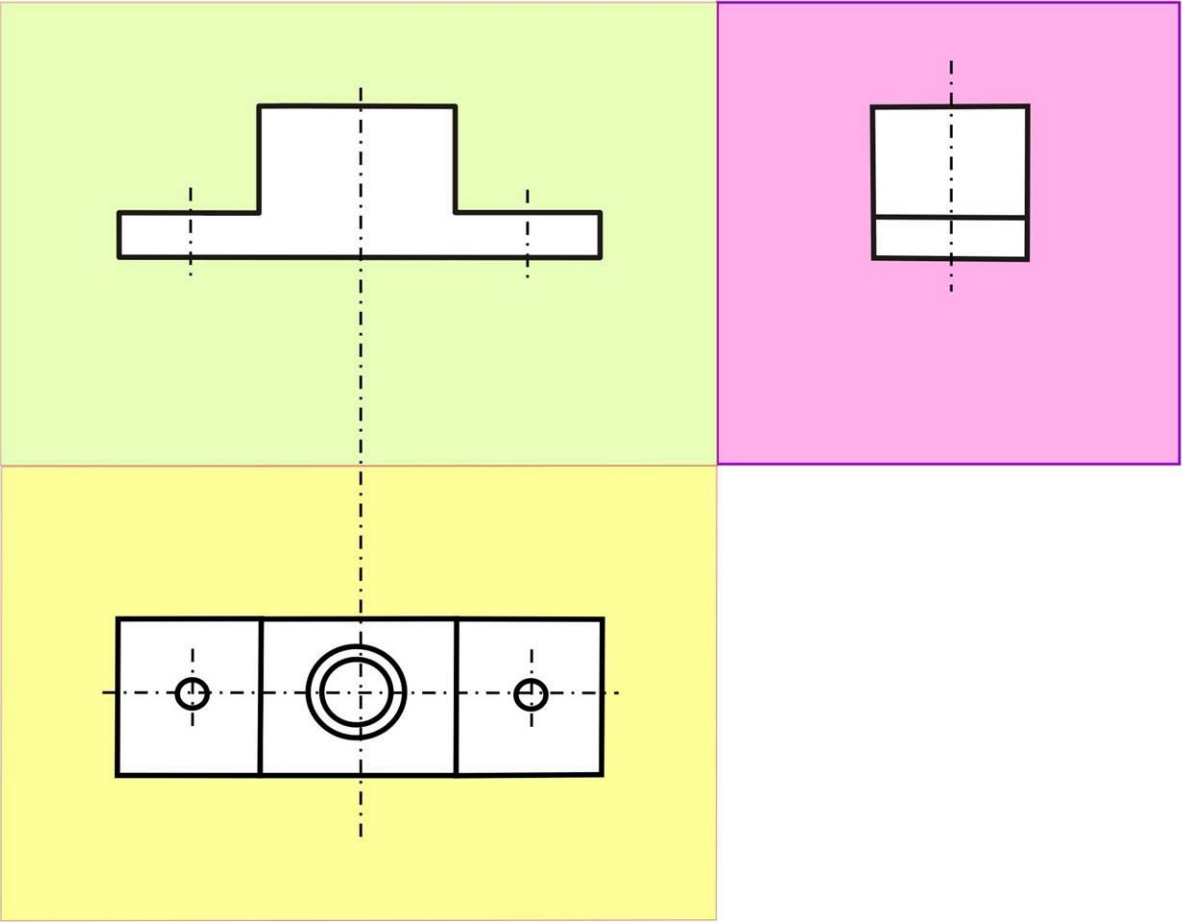

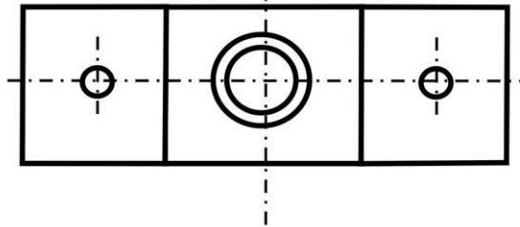
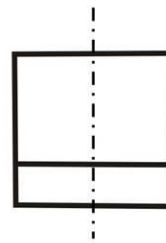
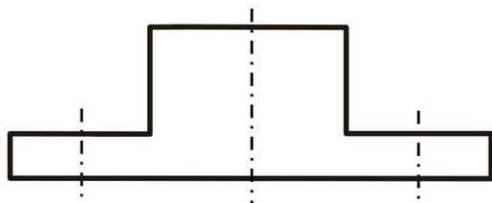

# A nézetek tartalma

az alkatrész valódi alakjának vetületei

# A NÉZETEK ELHELYEZÉSI RENDJE

# Rendezett nézetek

Nem kell külön jelölni a nézet helyét

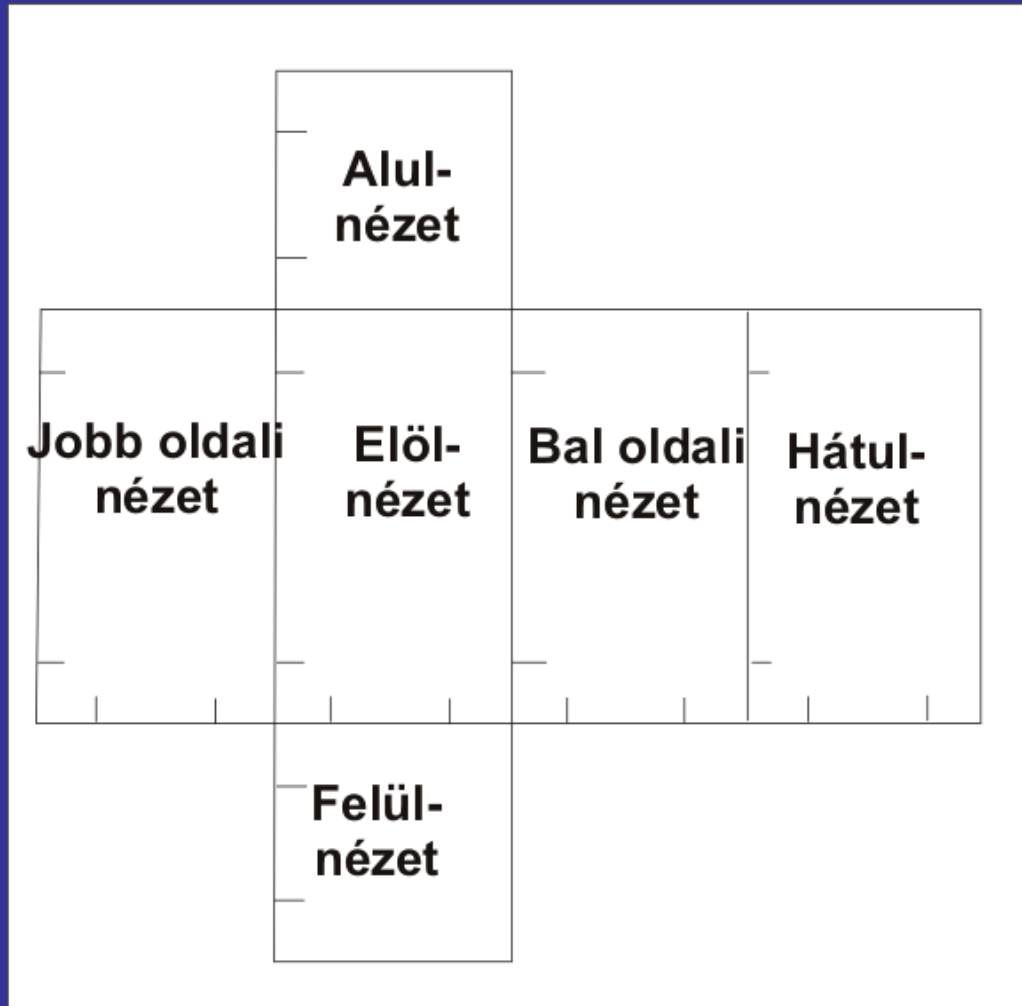



**KÜLÖNLEGES NÉZETEK**

# A rendezett vetületektől eltérő nézetelhelyezés

**Célja:** a rajz áttekinthetőbb összképének kialakítása

**Indoka:** nincs hely ott, ahova tenni kellene

**Jelölése:** nézési irány megadásával

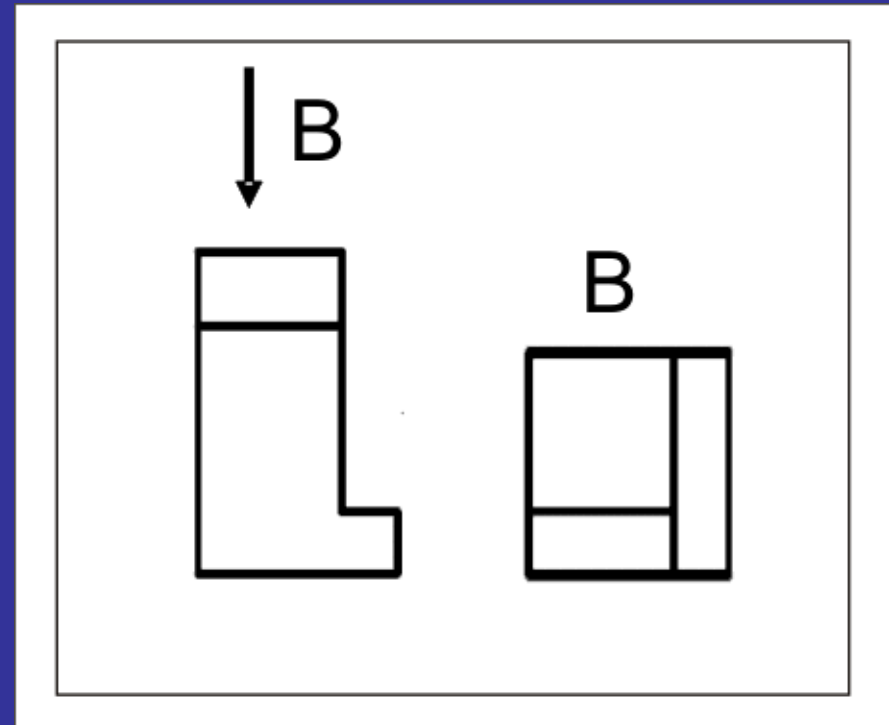
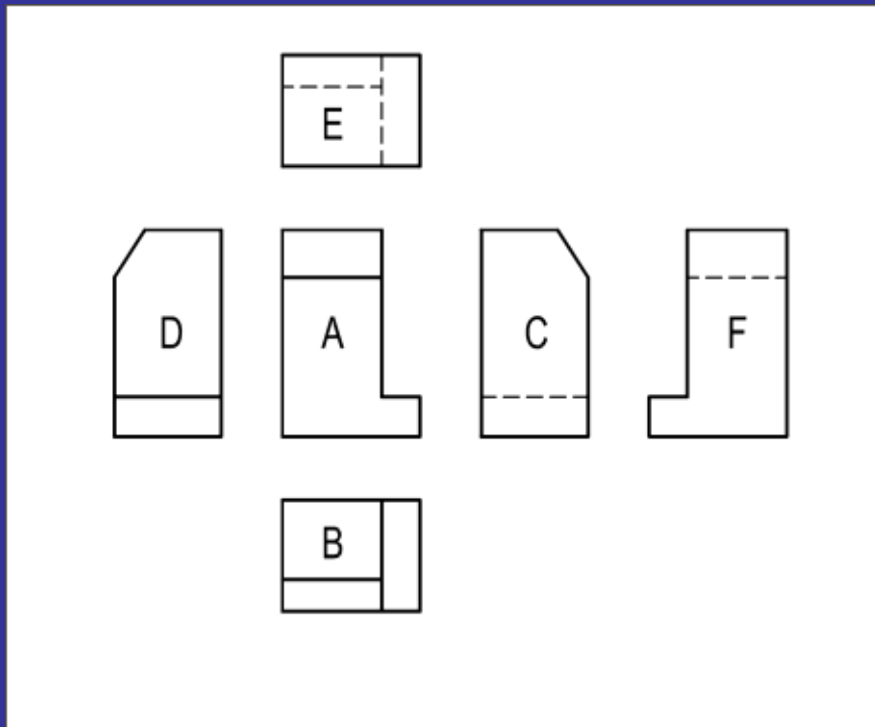

# Résznézet

**Célja:** valamely részlet torzulásmentes ábrázolása

**Elhelyezése:** a nézetrendtől eltérően (a tárgyészlet IV. képe)

**Jelölése:** nézési irány megadásával

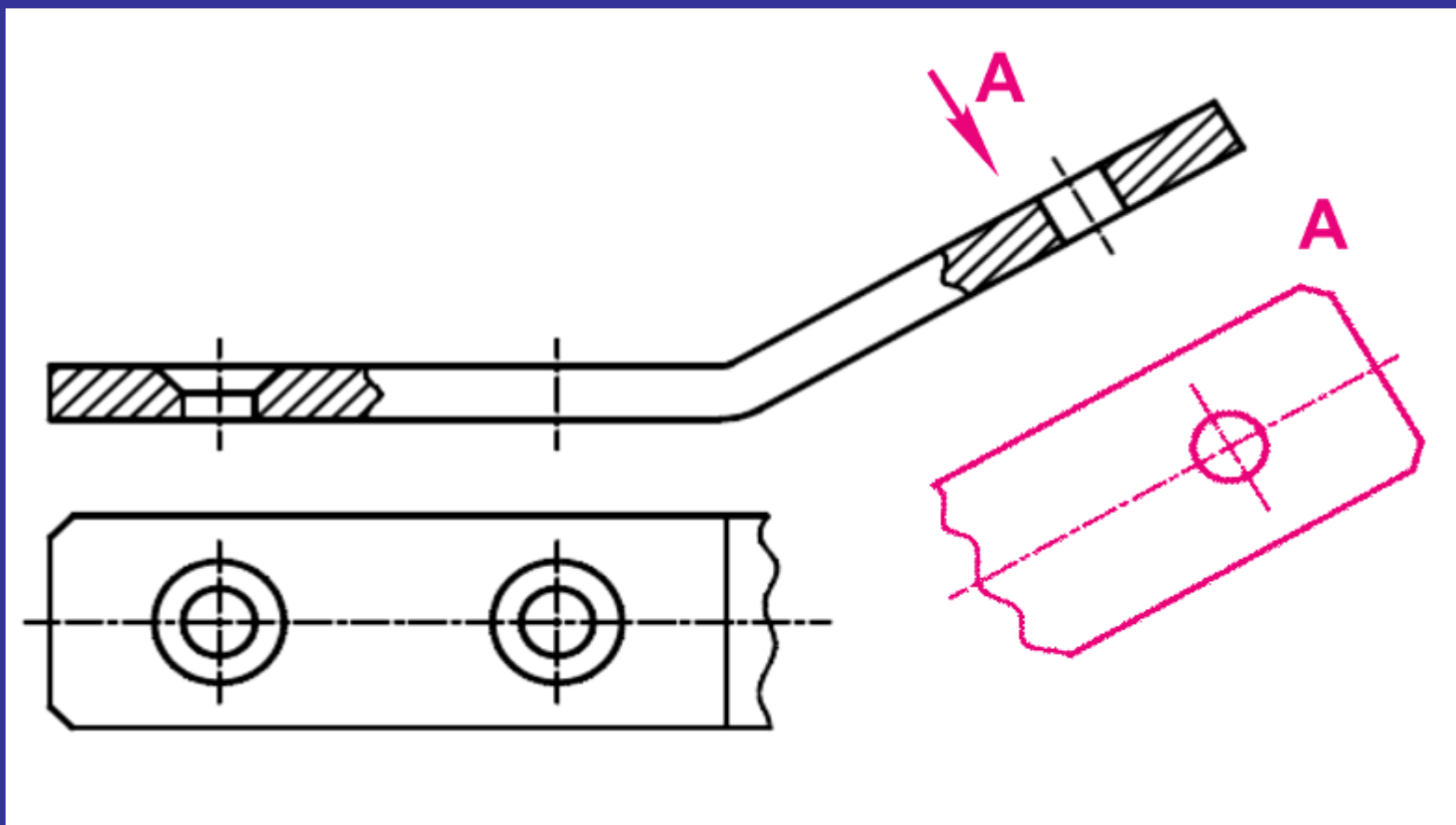

# Részvetület (az érdektelen részletet elhagyjuk)

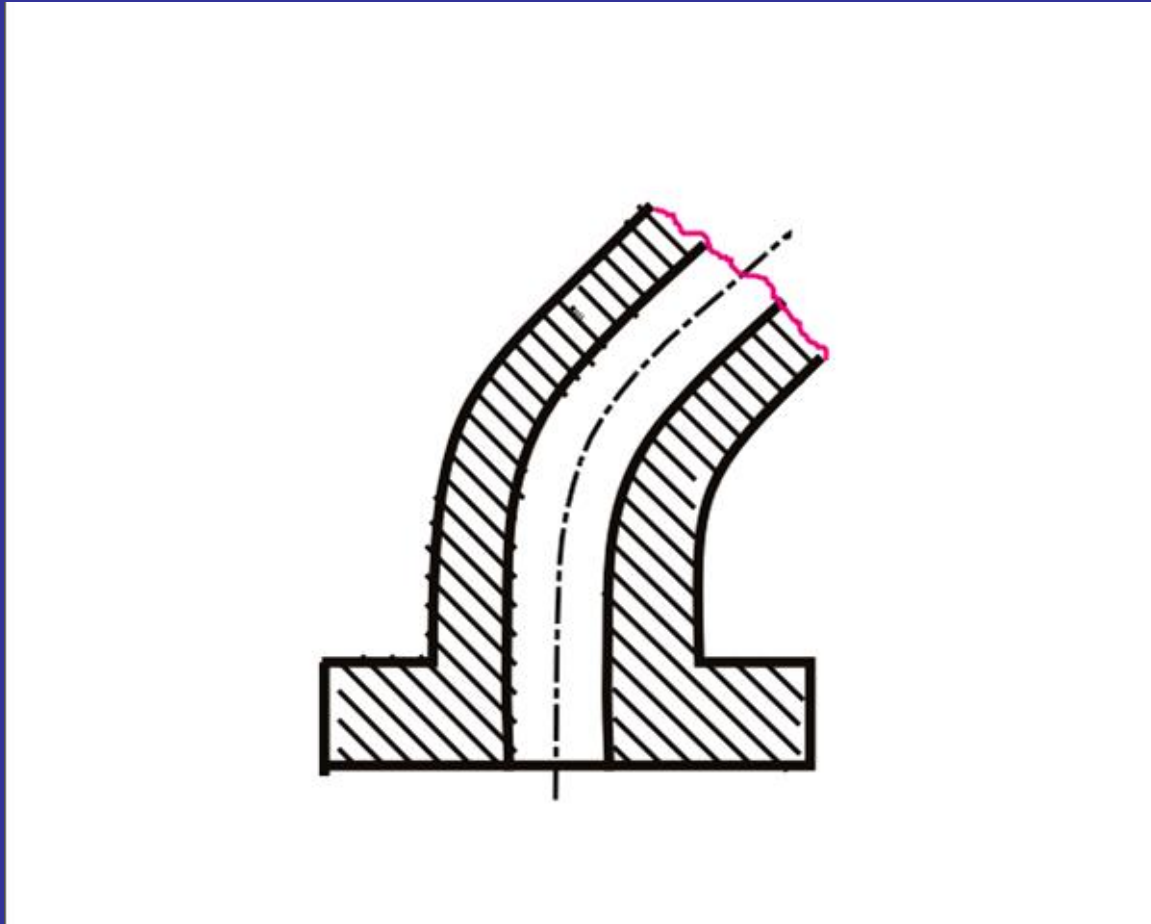

# Helyi nézet

**Célja:** valamely részlet „kiegészítő” magyarázata

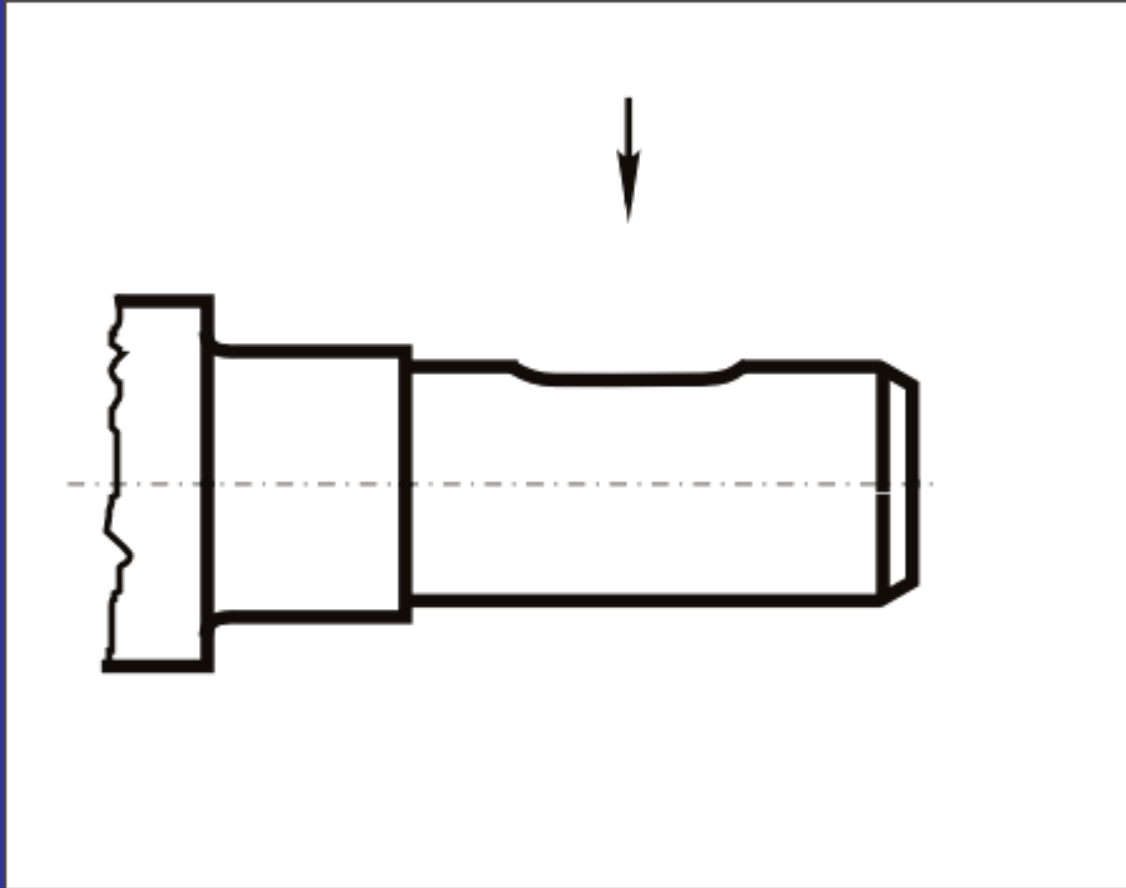

# Helyi nézet

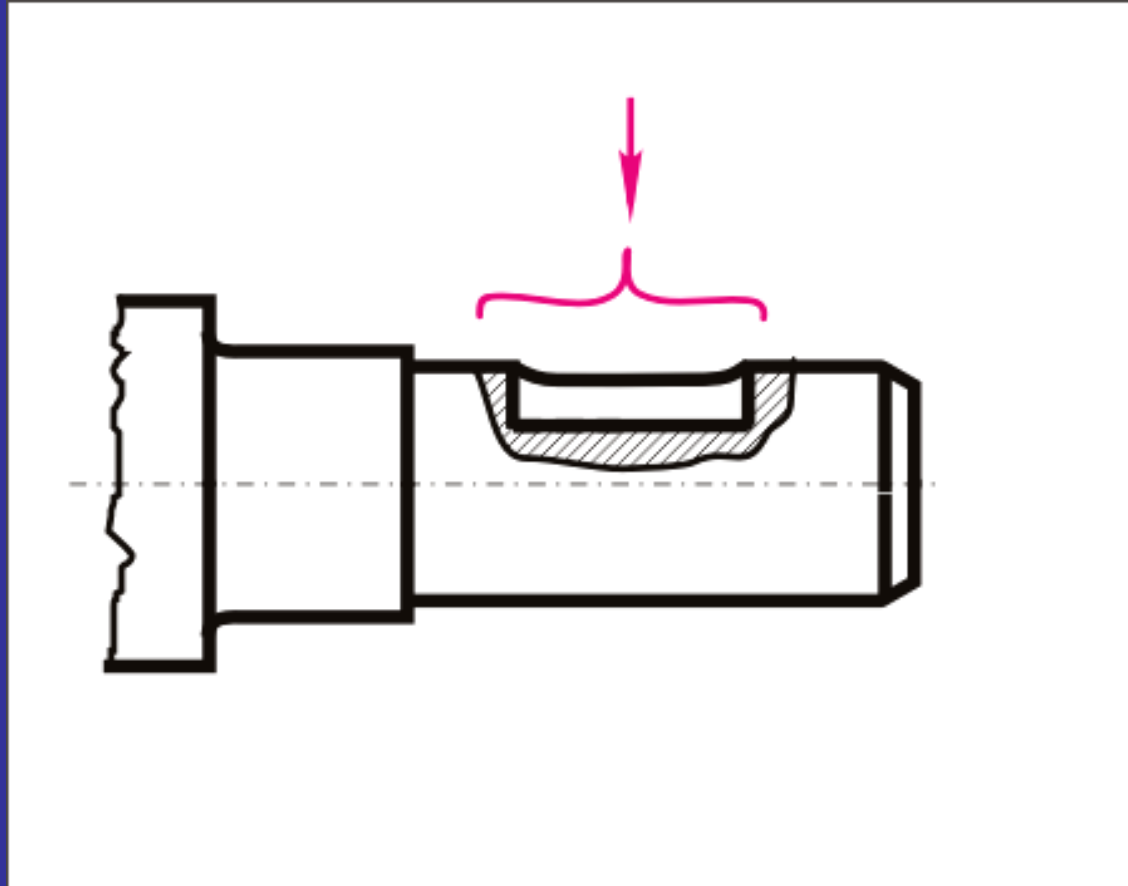

# Helyi nézet

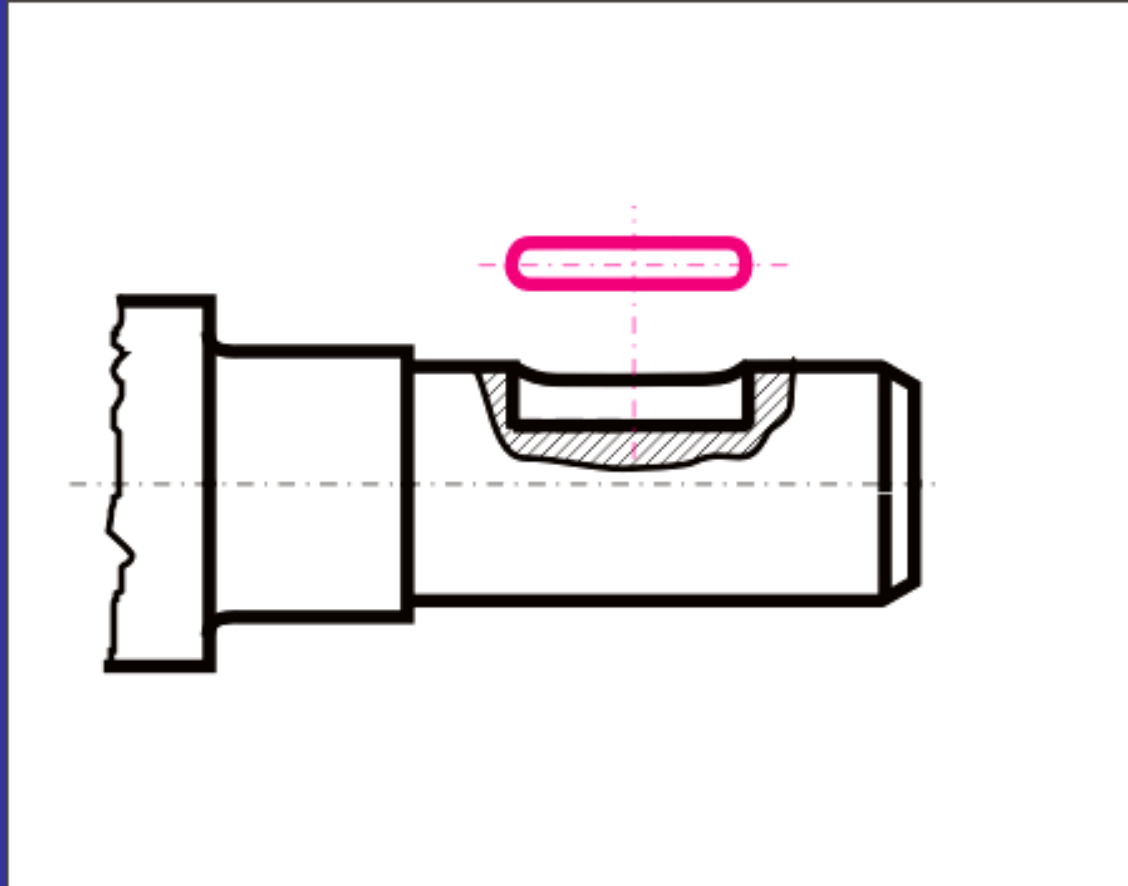

# Kiemelt részlet

Célja: valamely a részlet kinagyítása

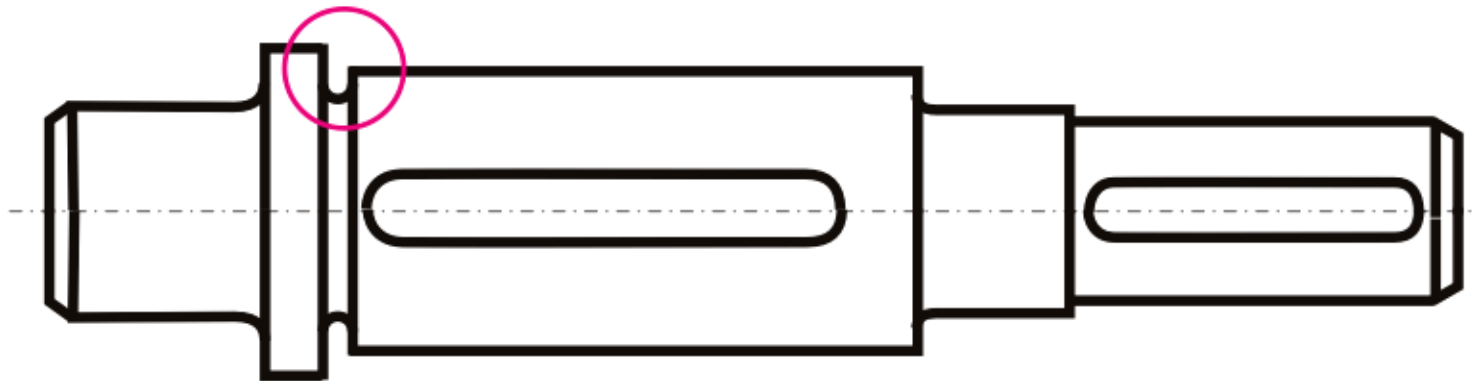



# Kiemelt részlet

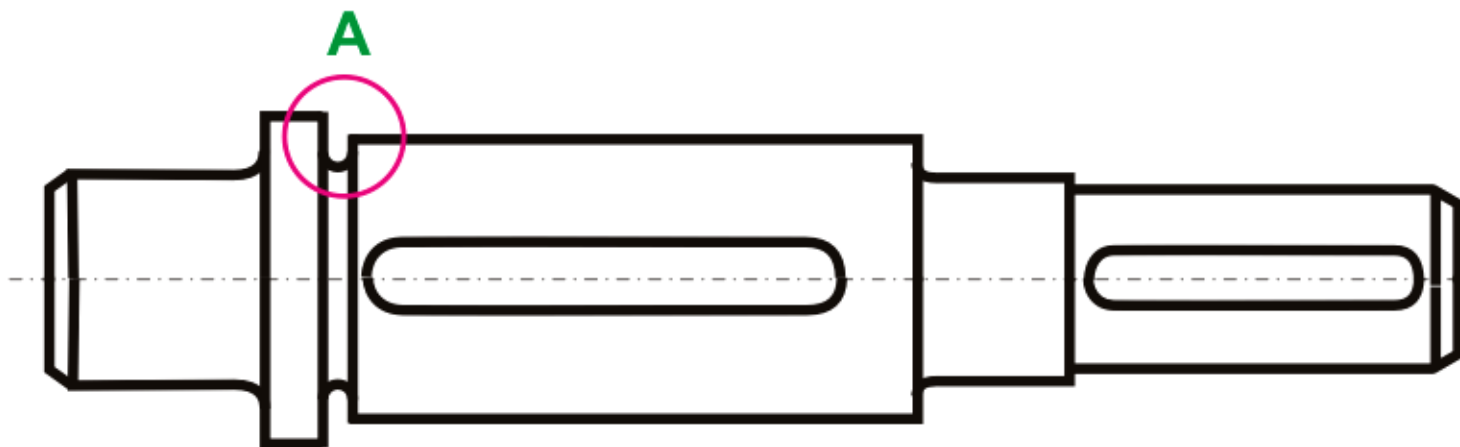

A (2:1)



# A METSZETEK

# A metszetkészítés célja

üreges alkatrészek belsejének  
megjelenítése

# A METSZETEK SZÁRMAZTATÁSA

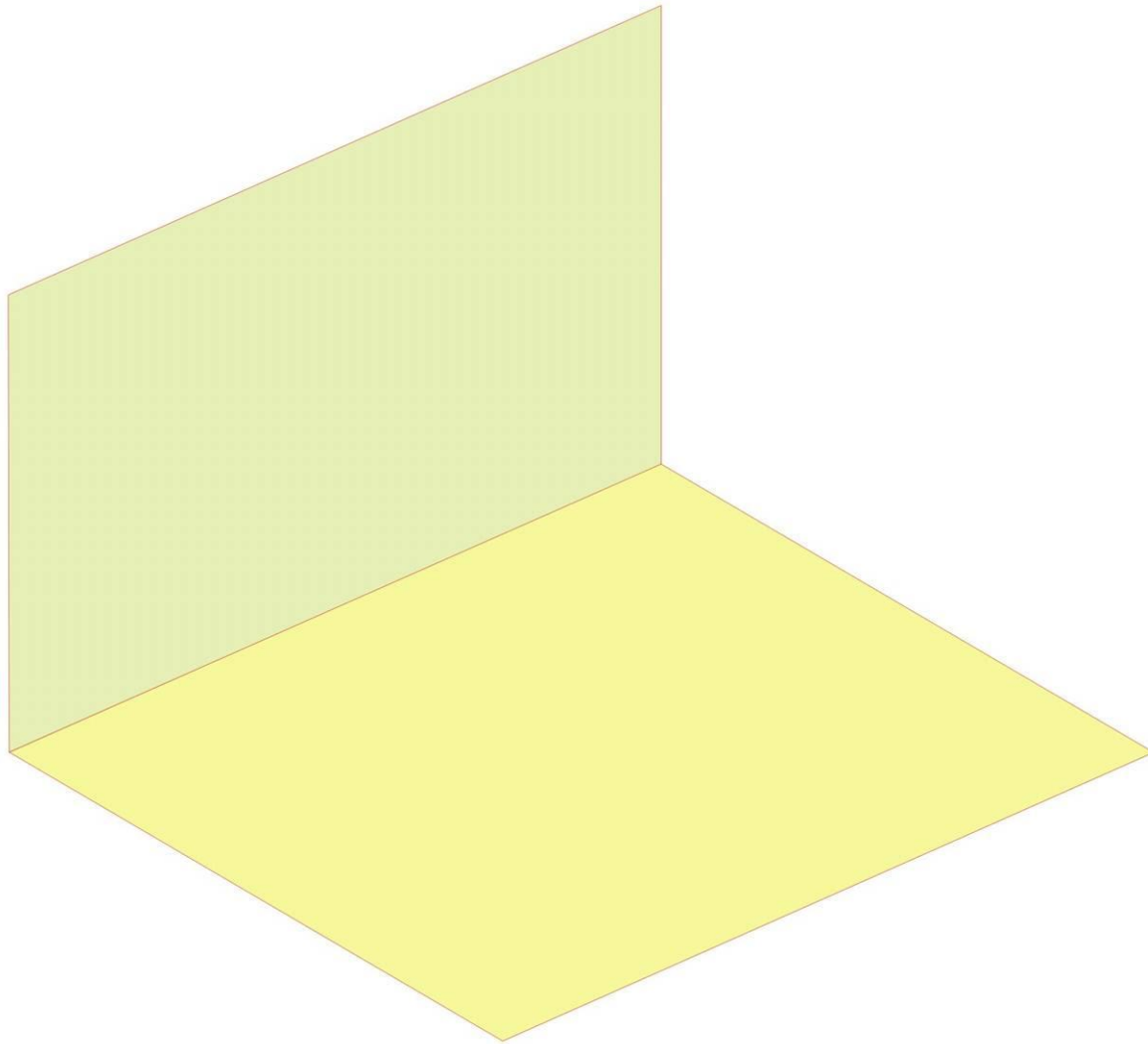

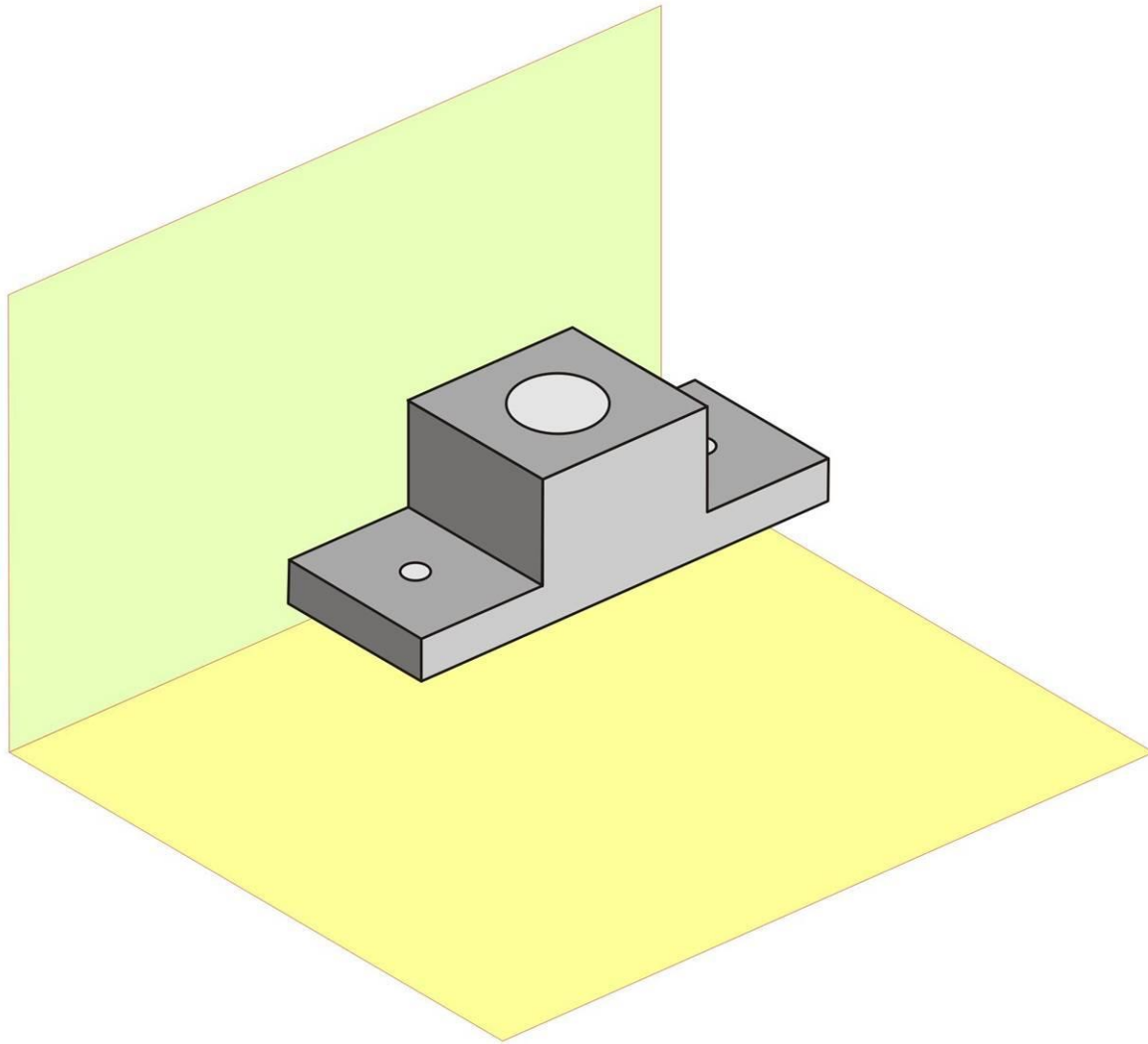

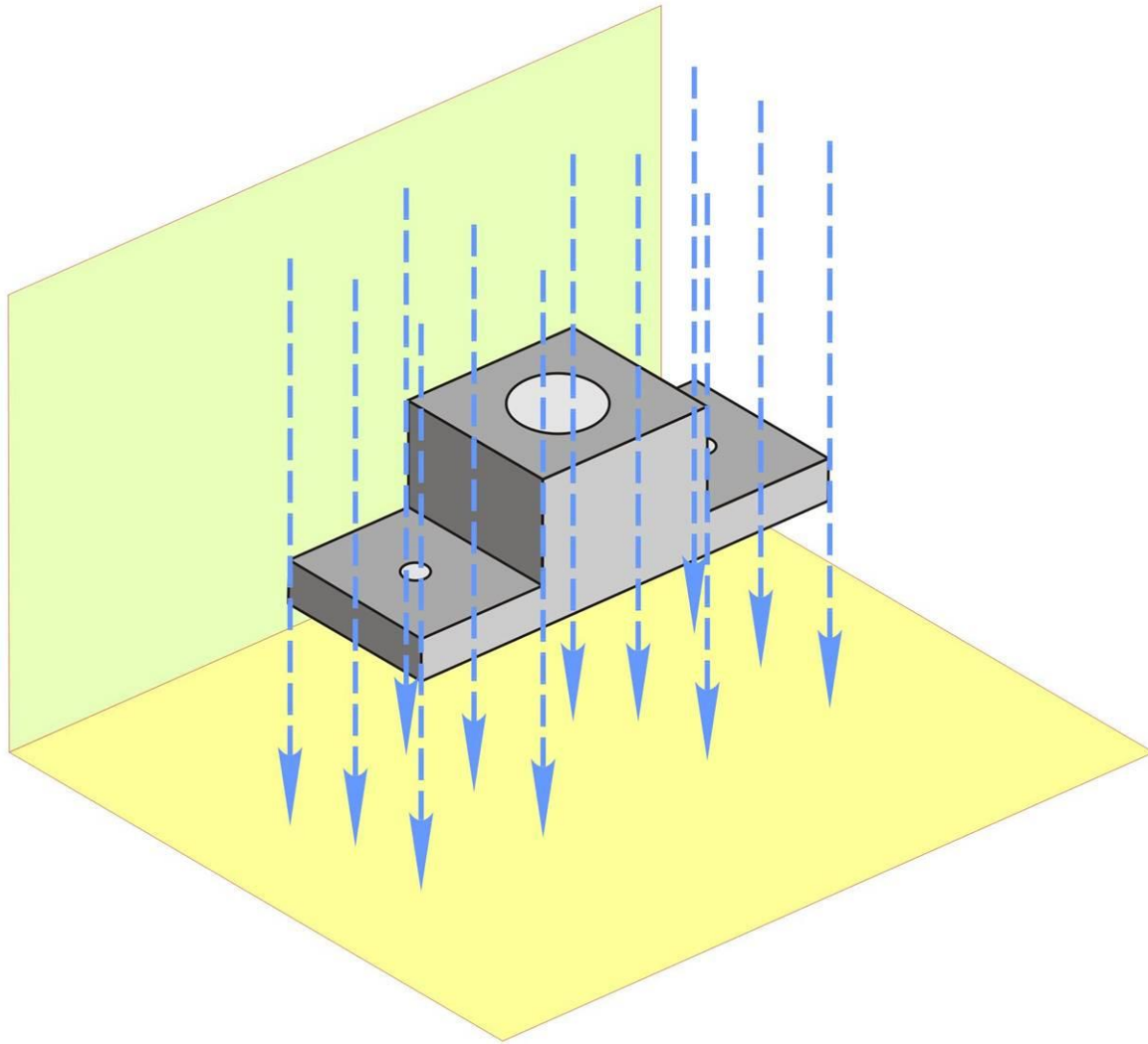

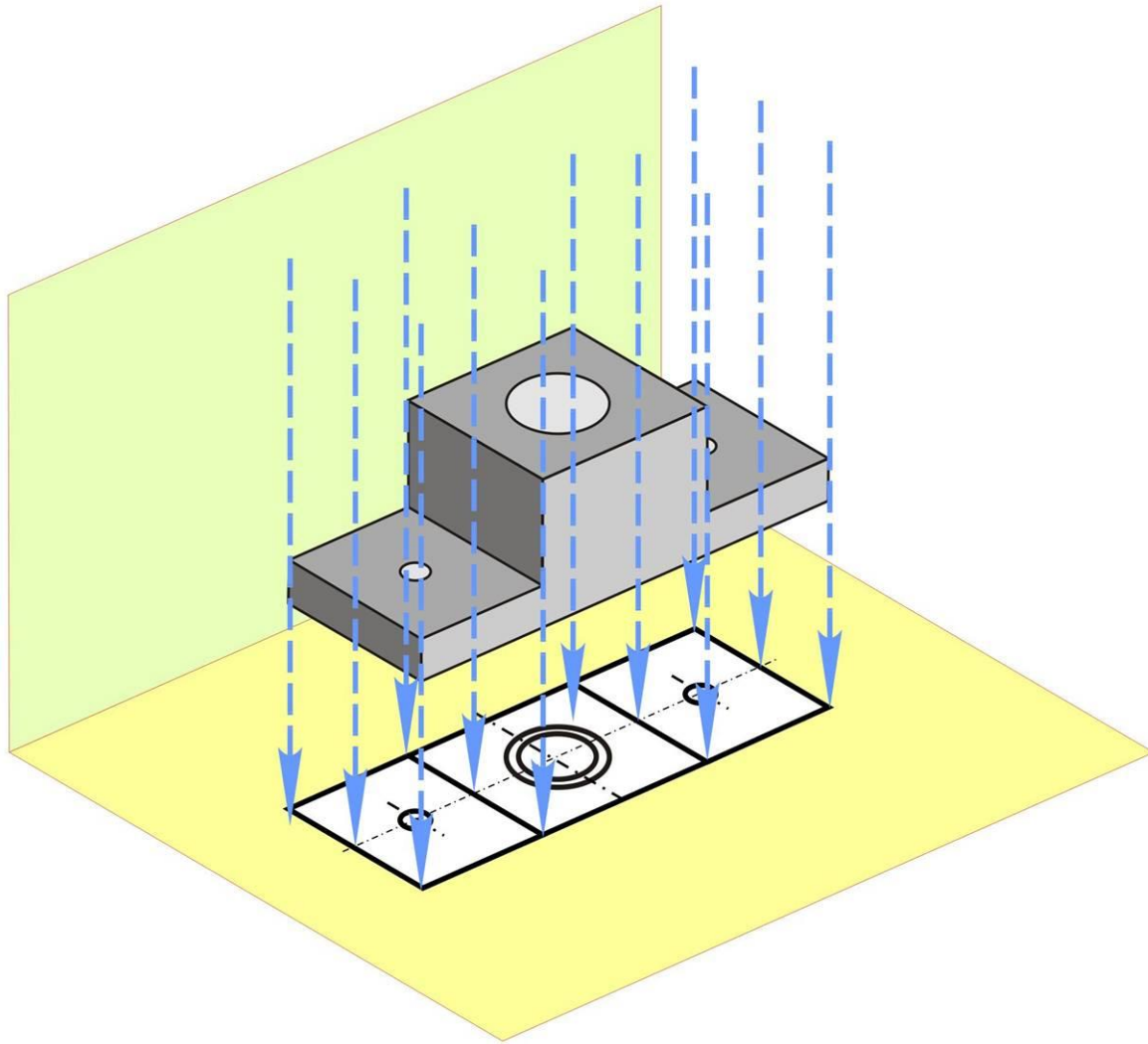



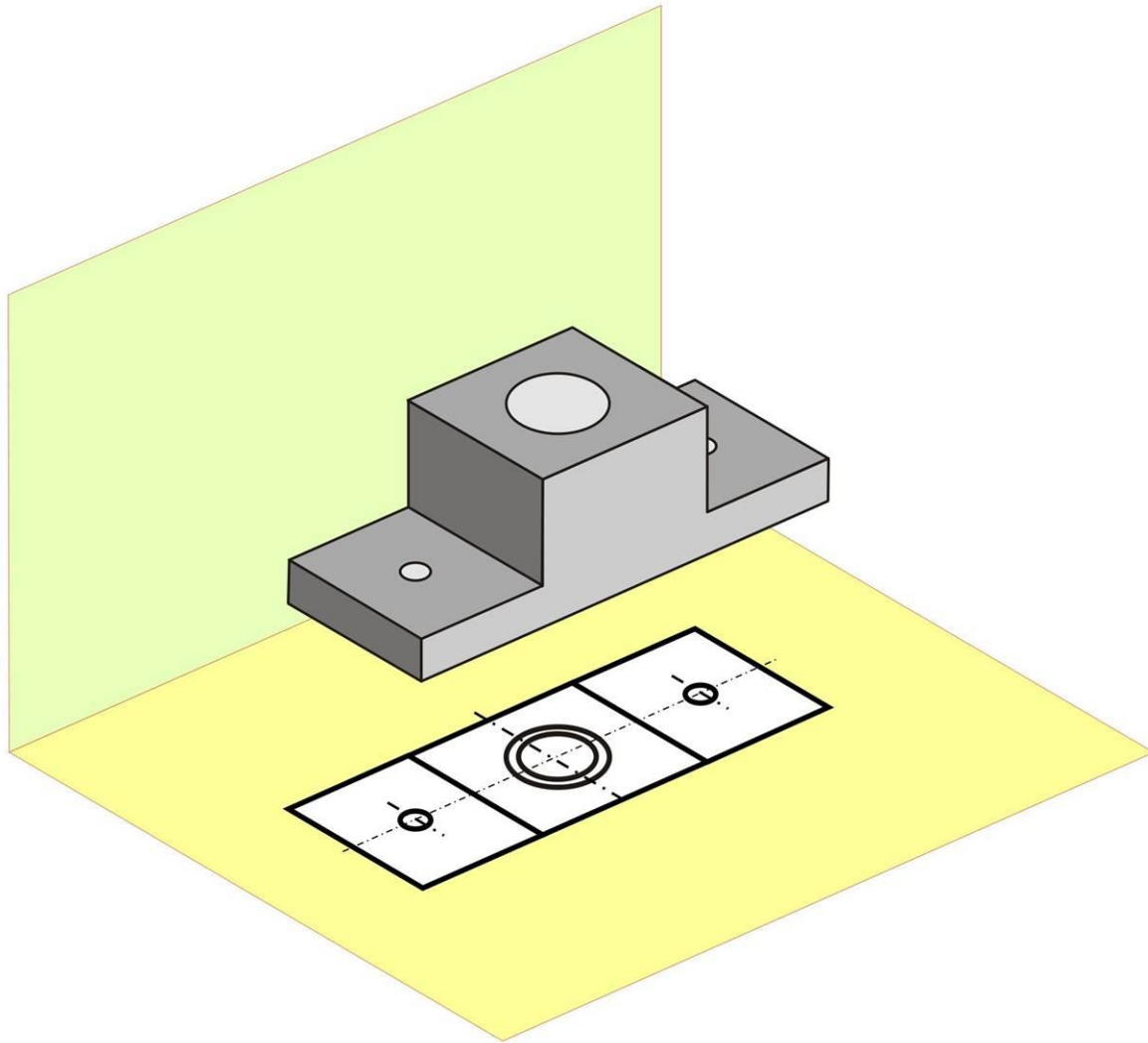

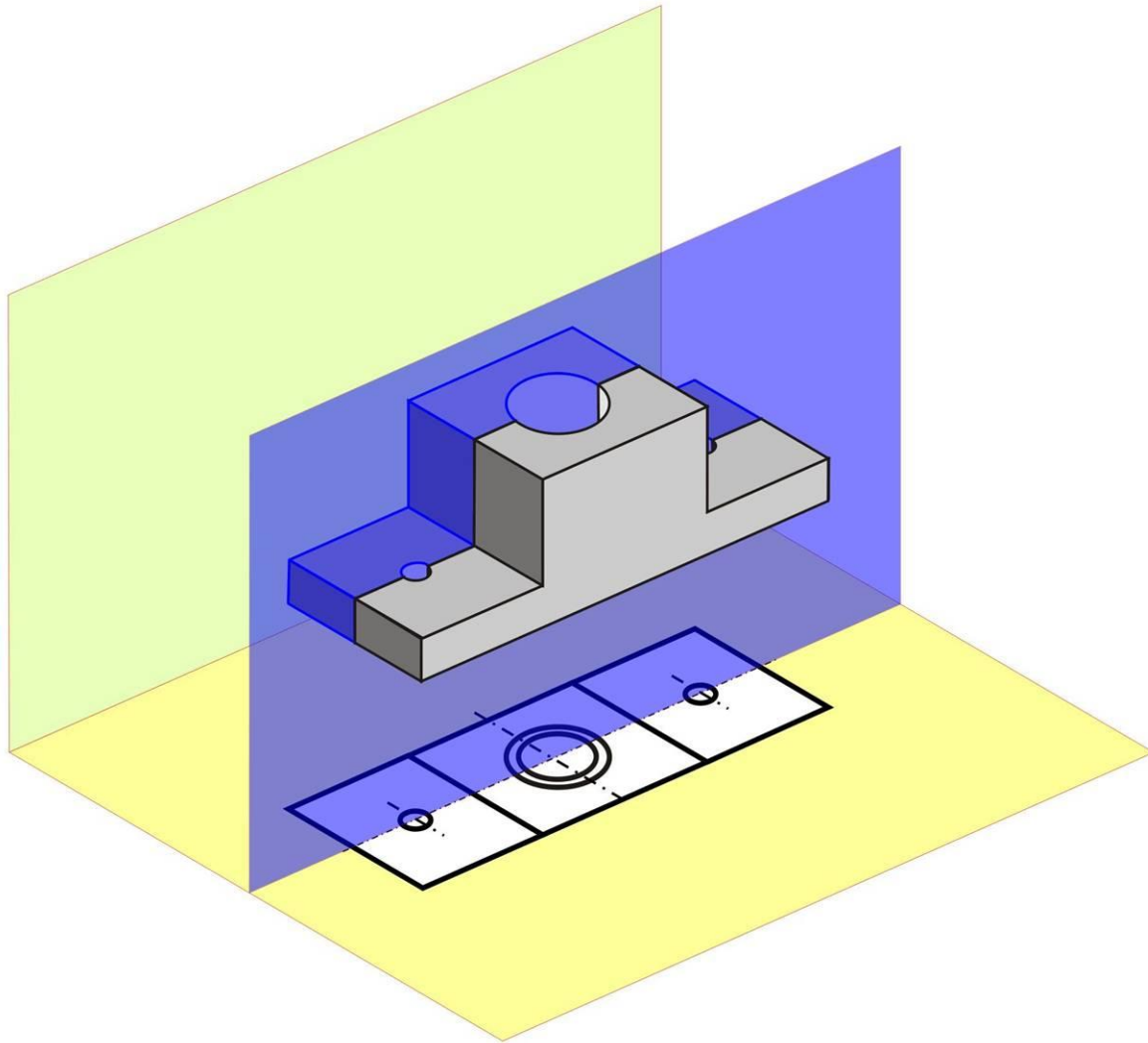

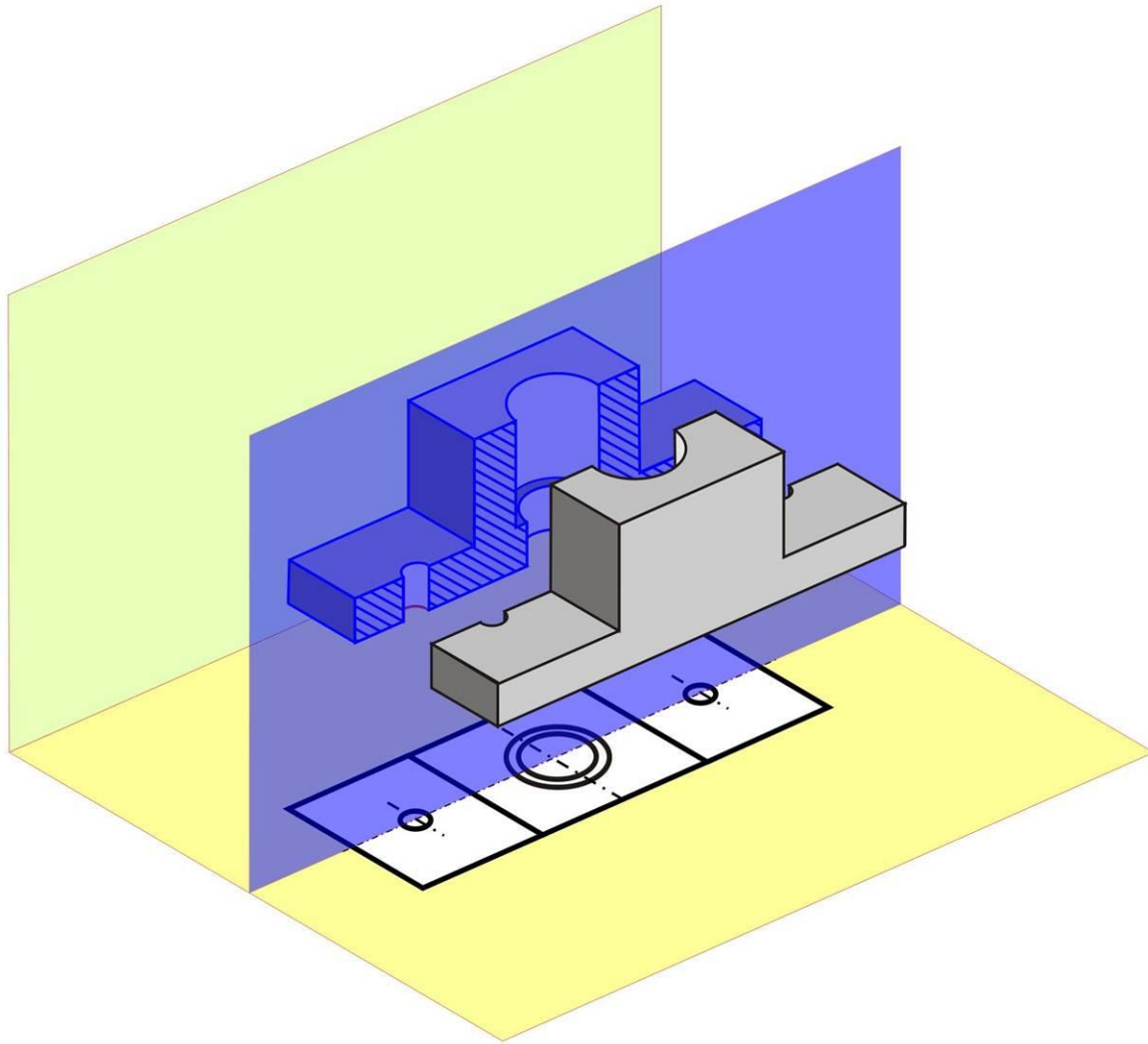

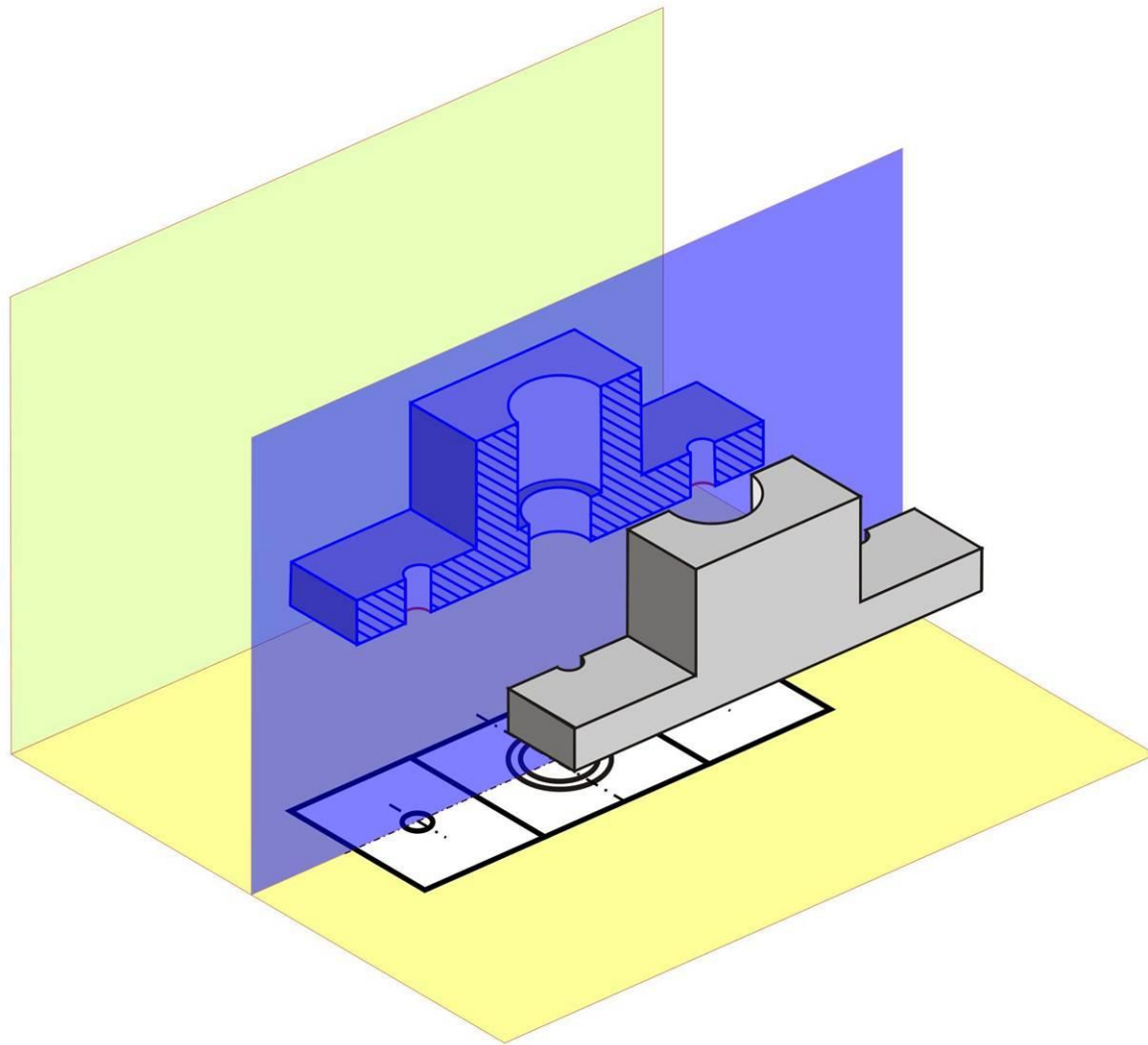

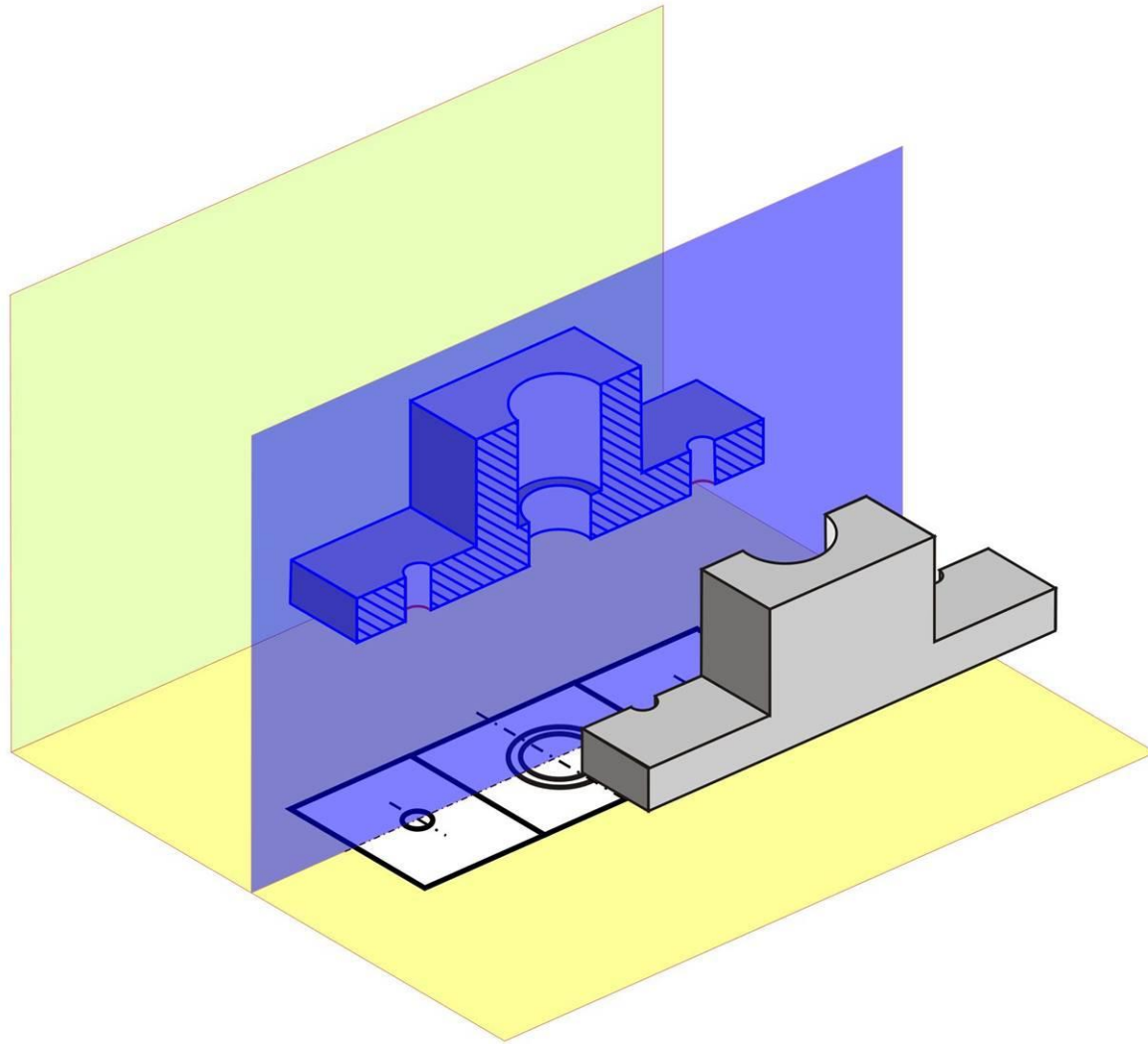

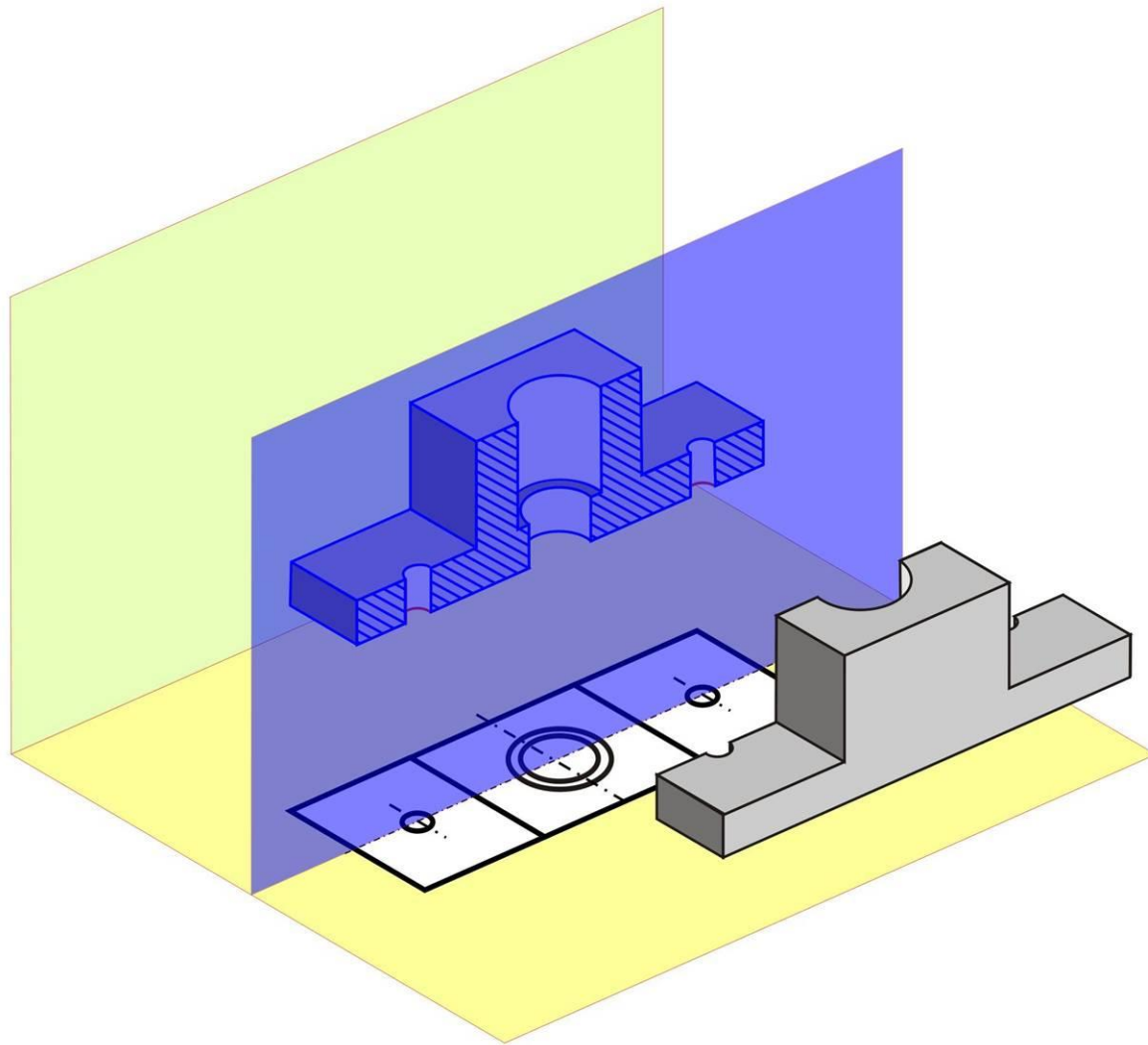

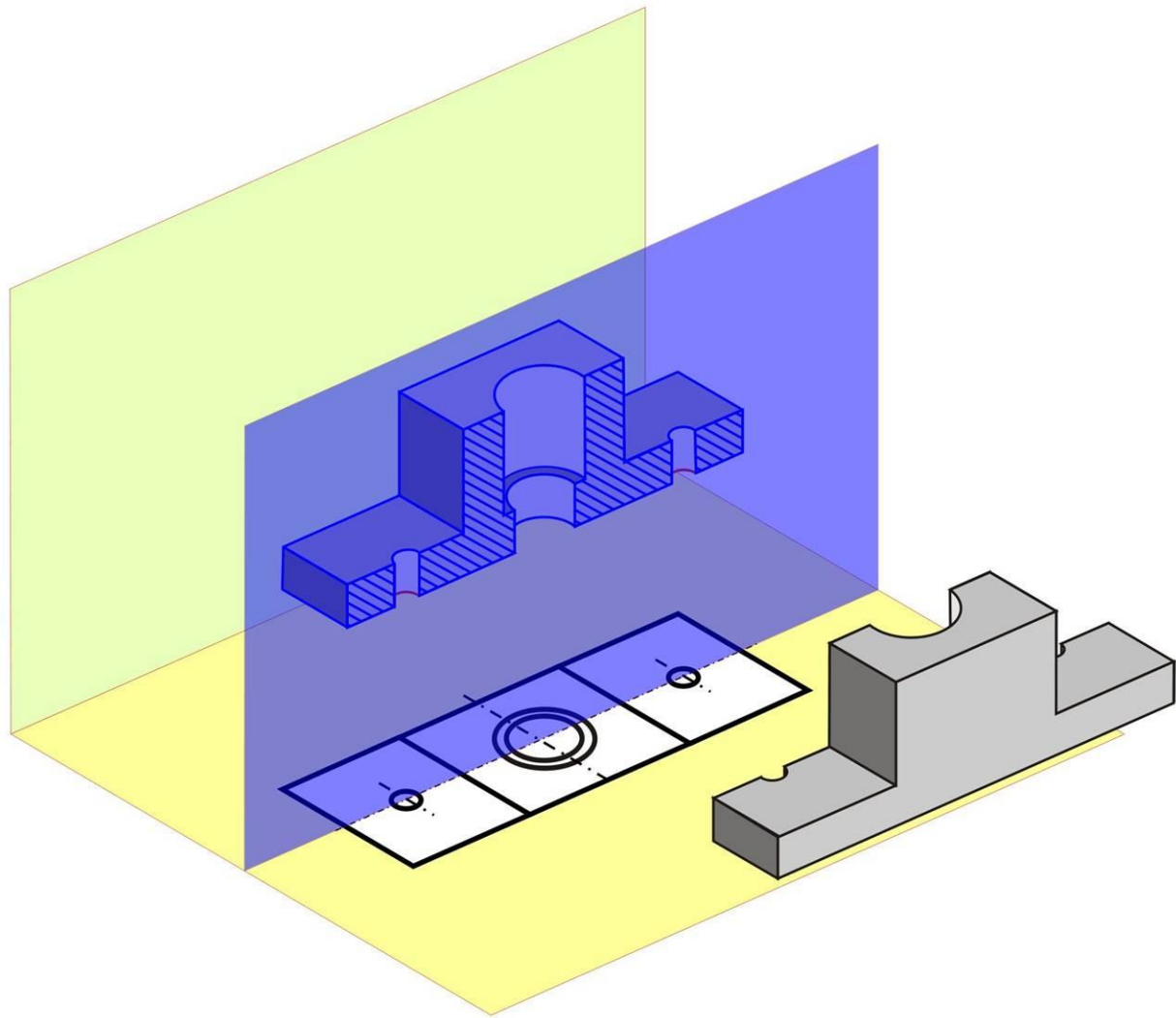

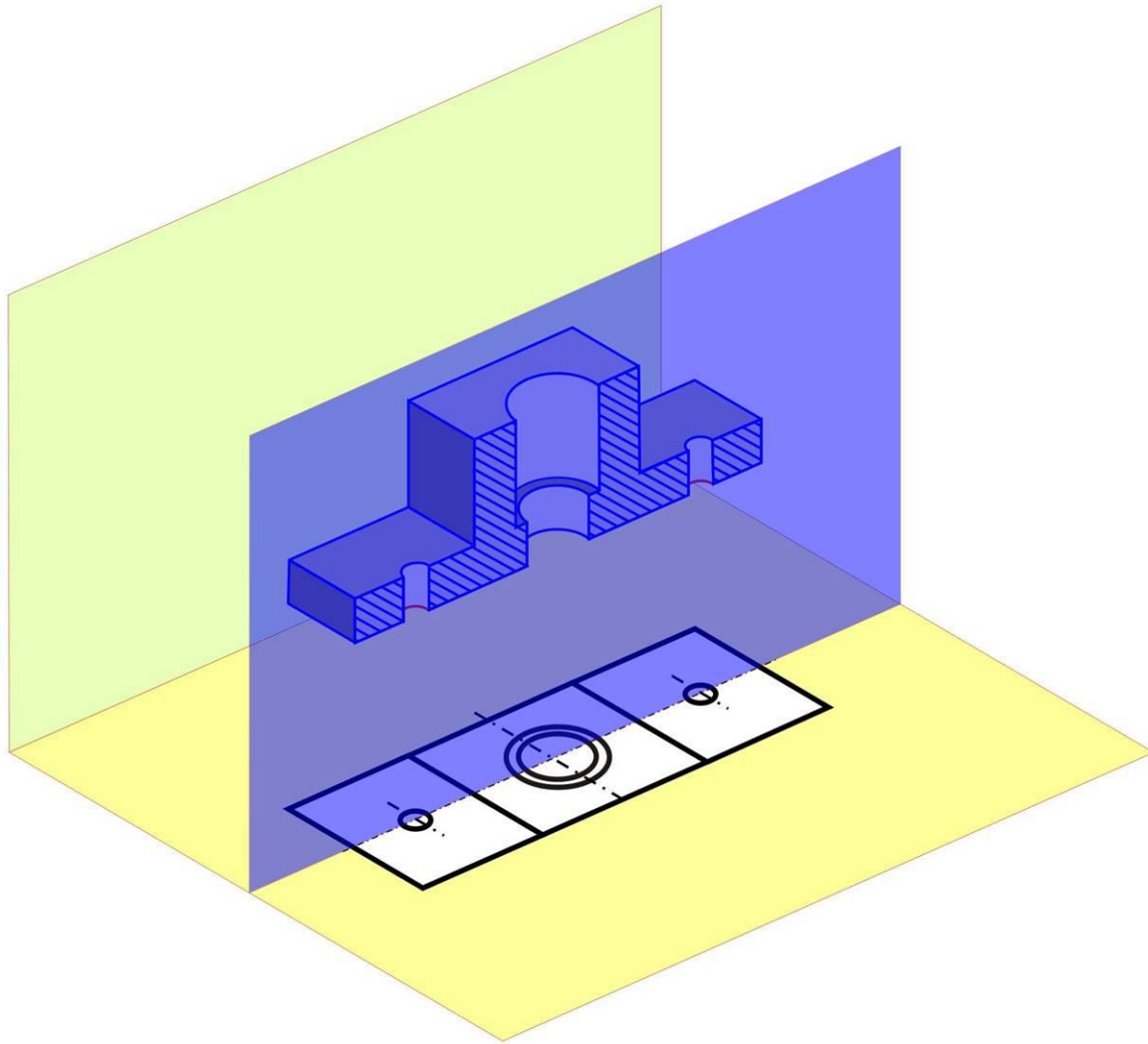



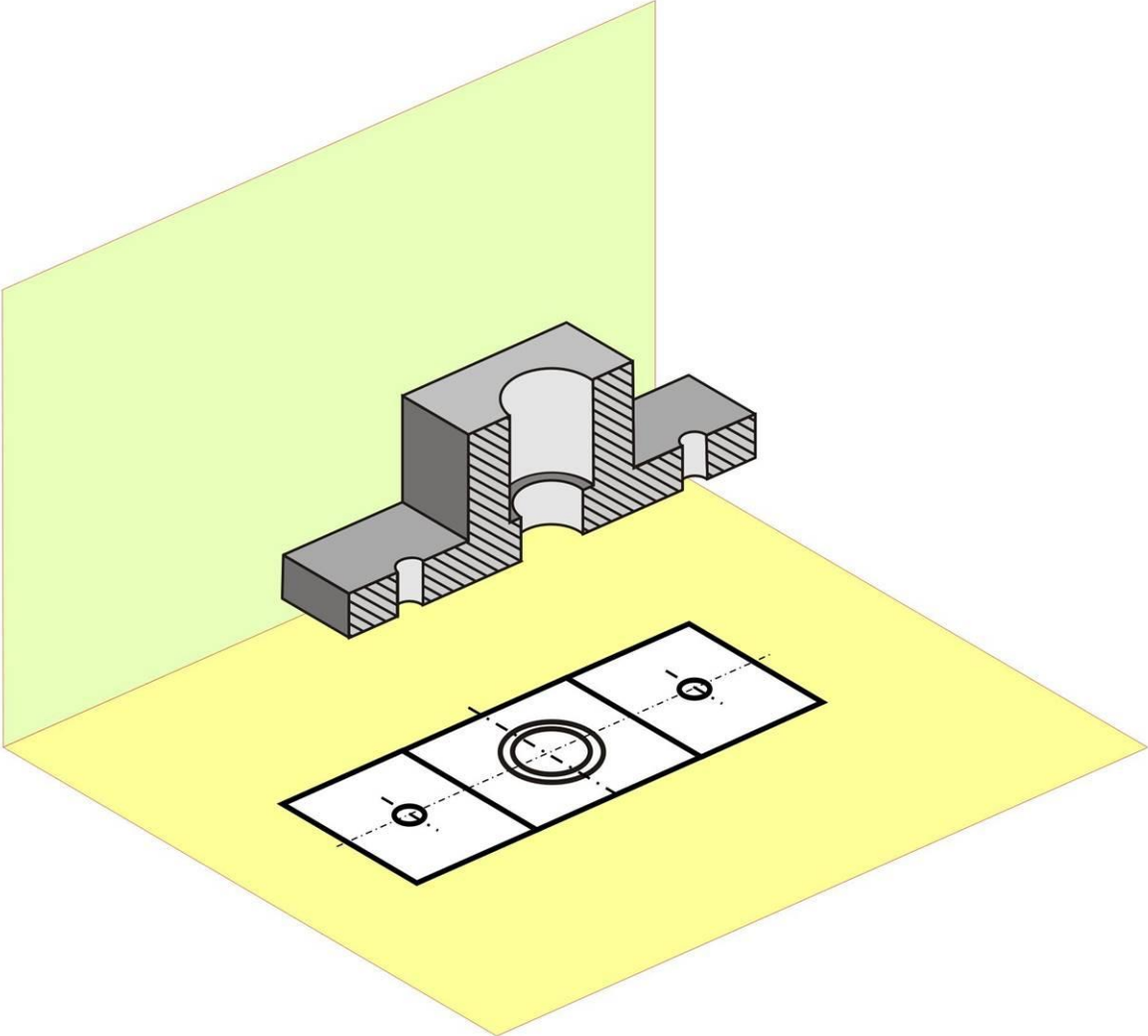

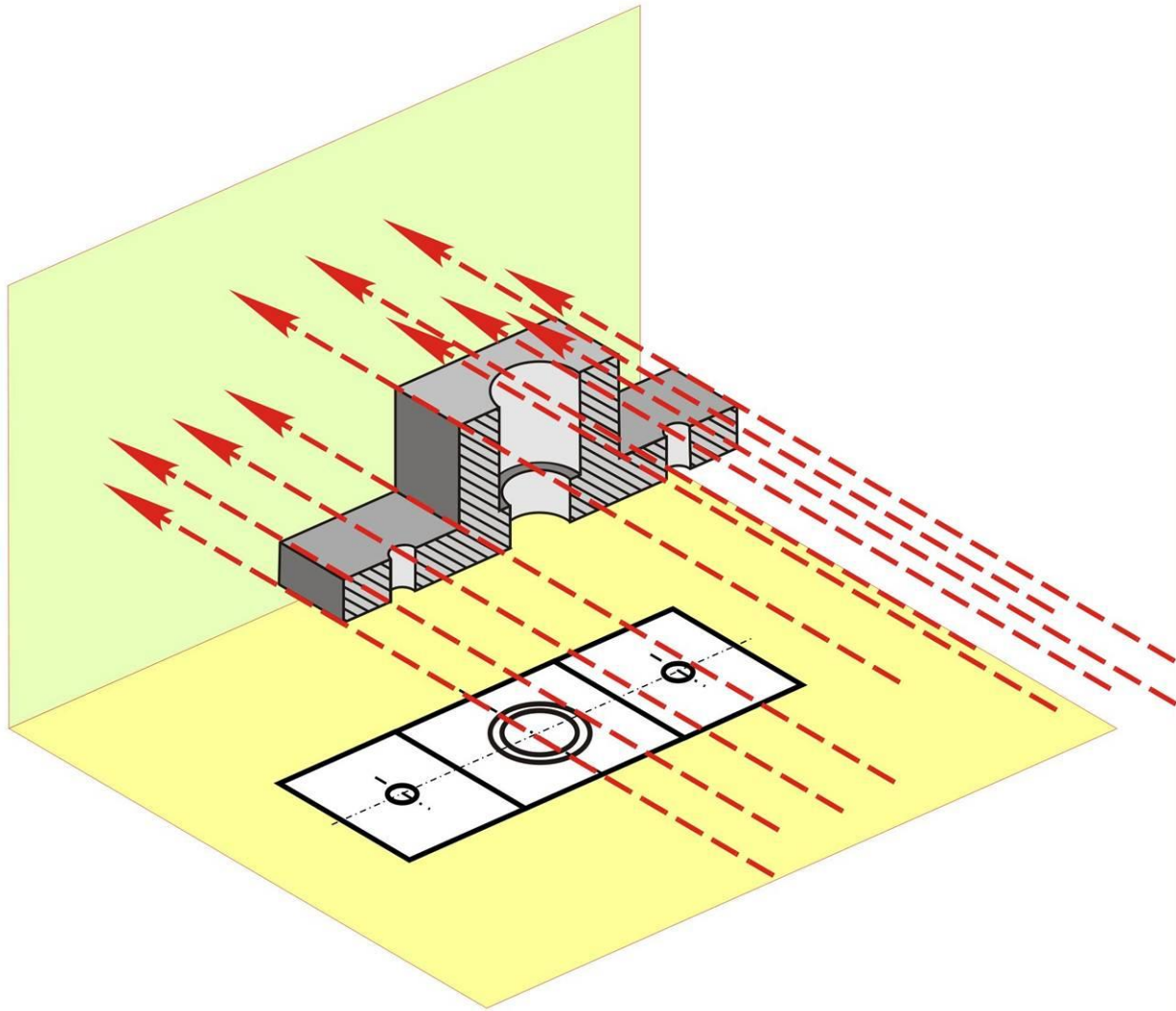

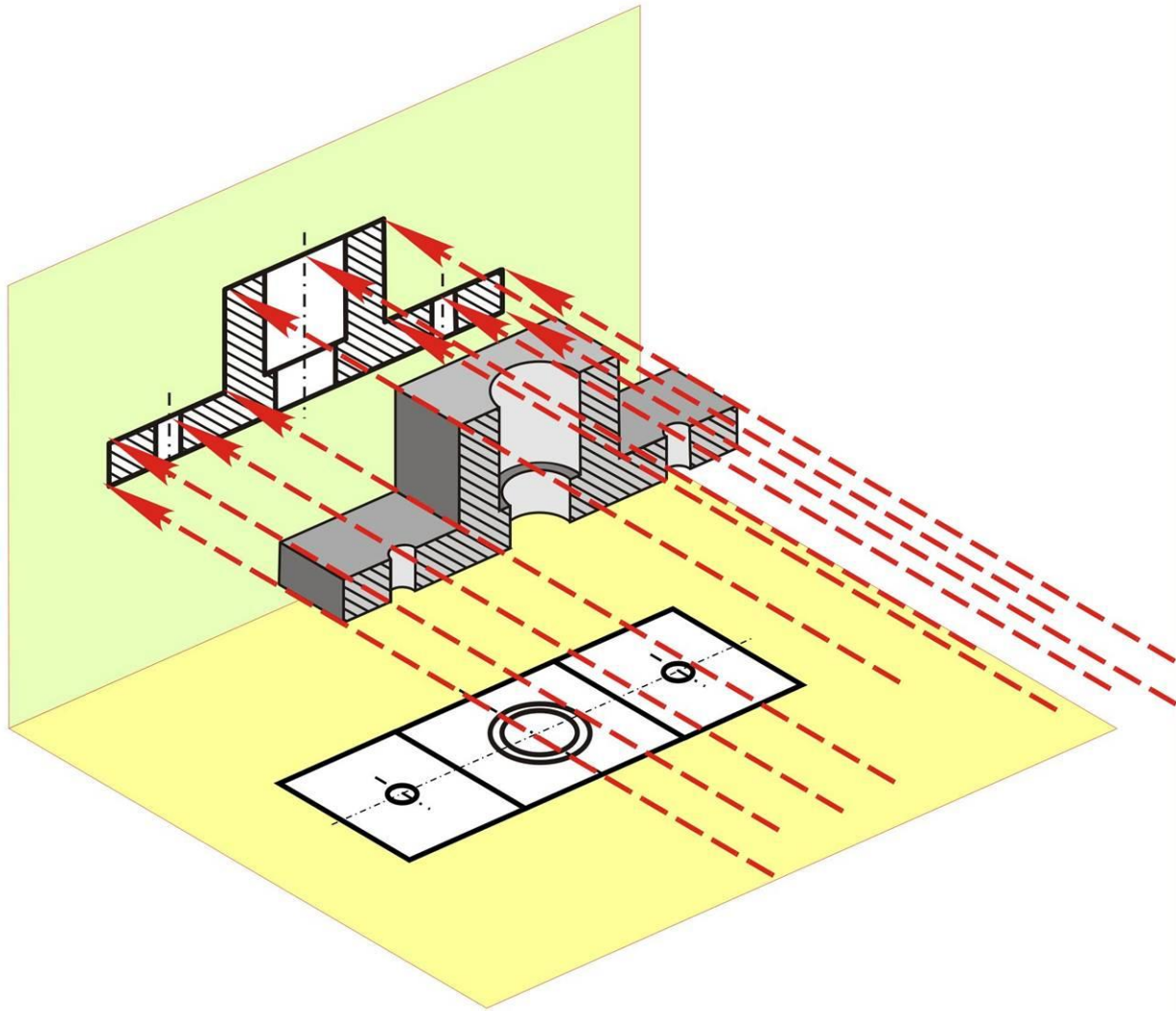

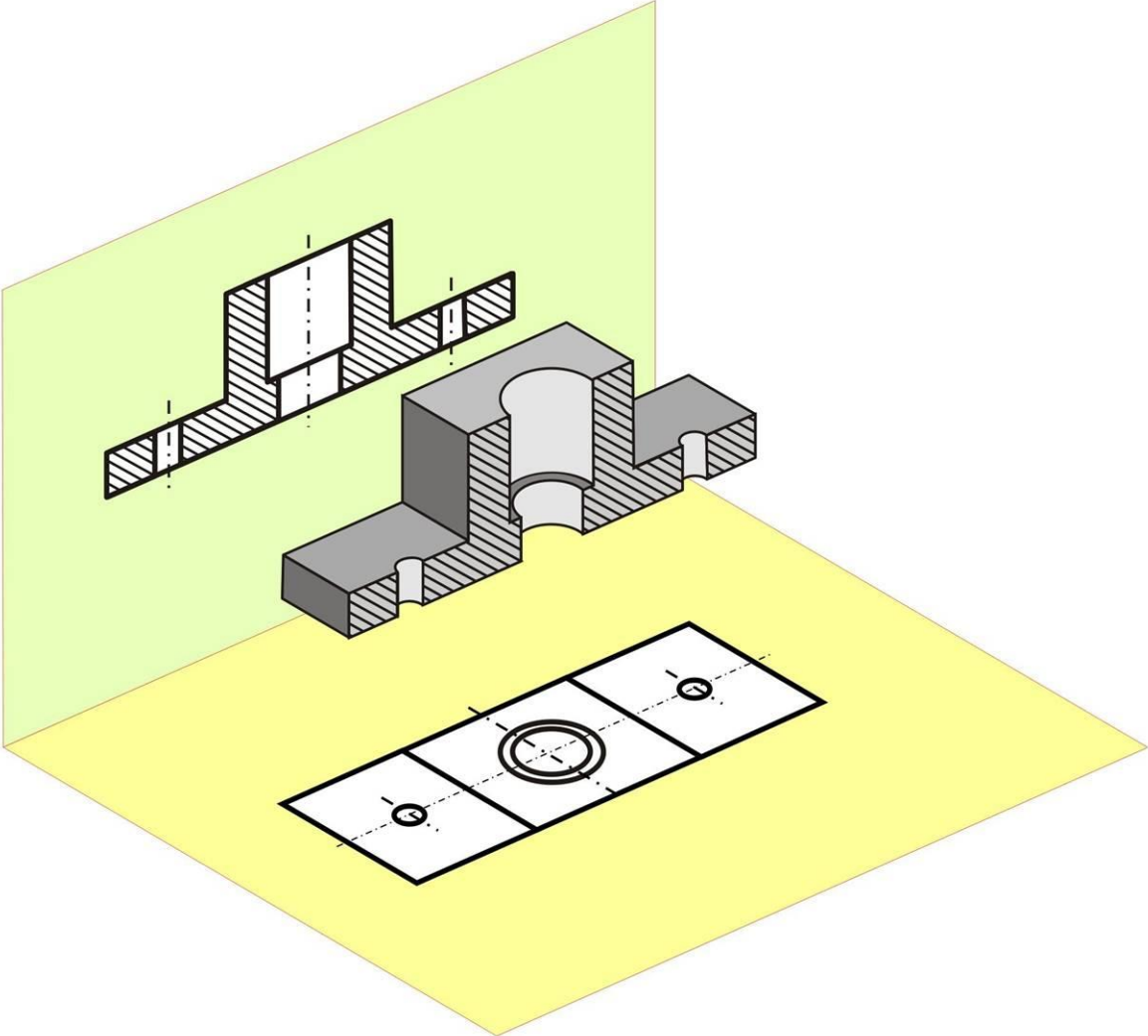

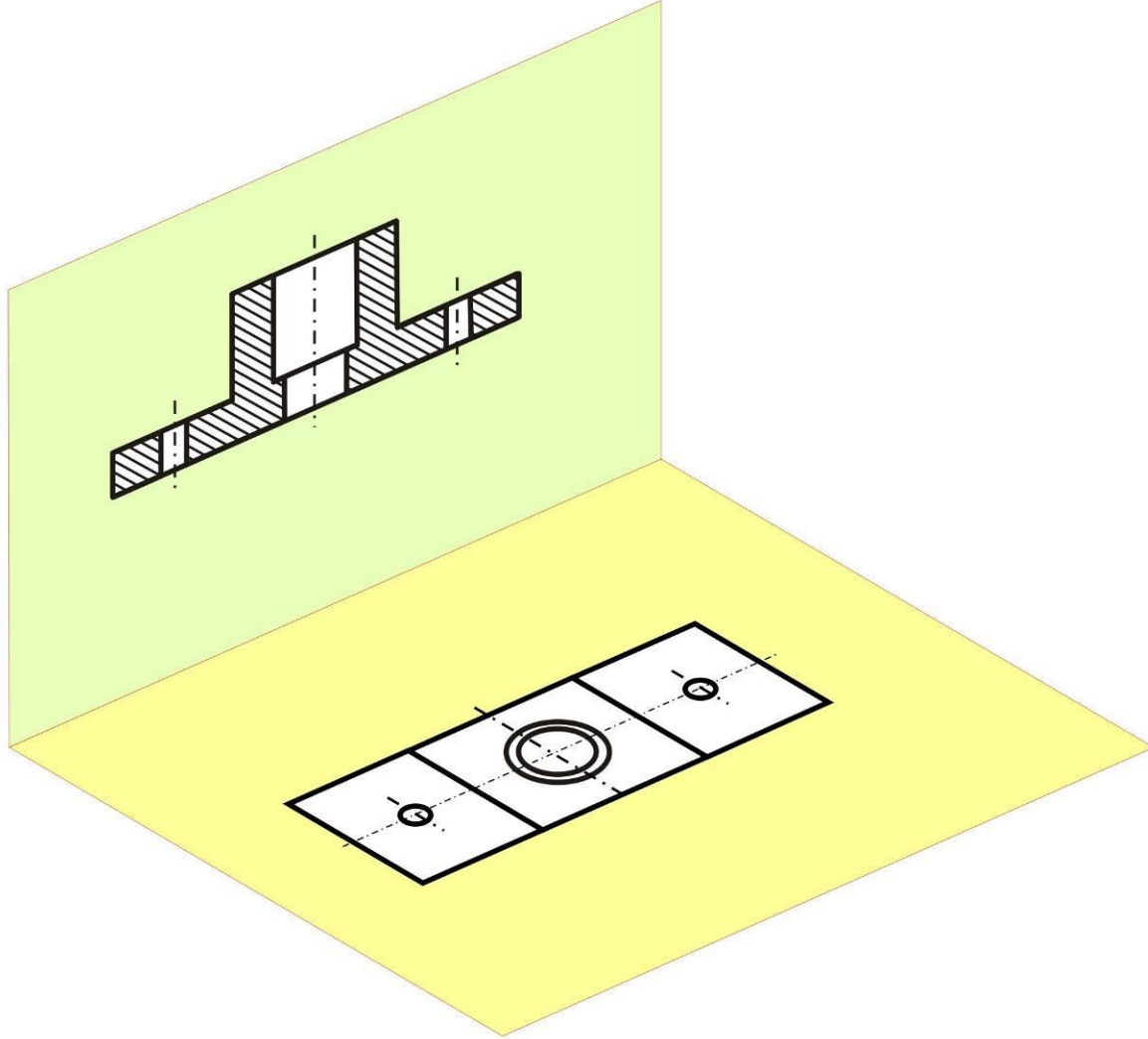

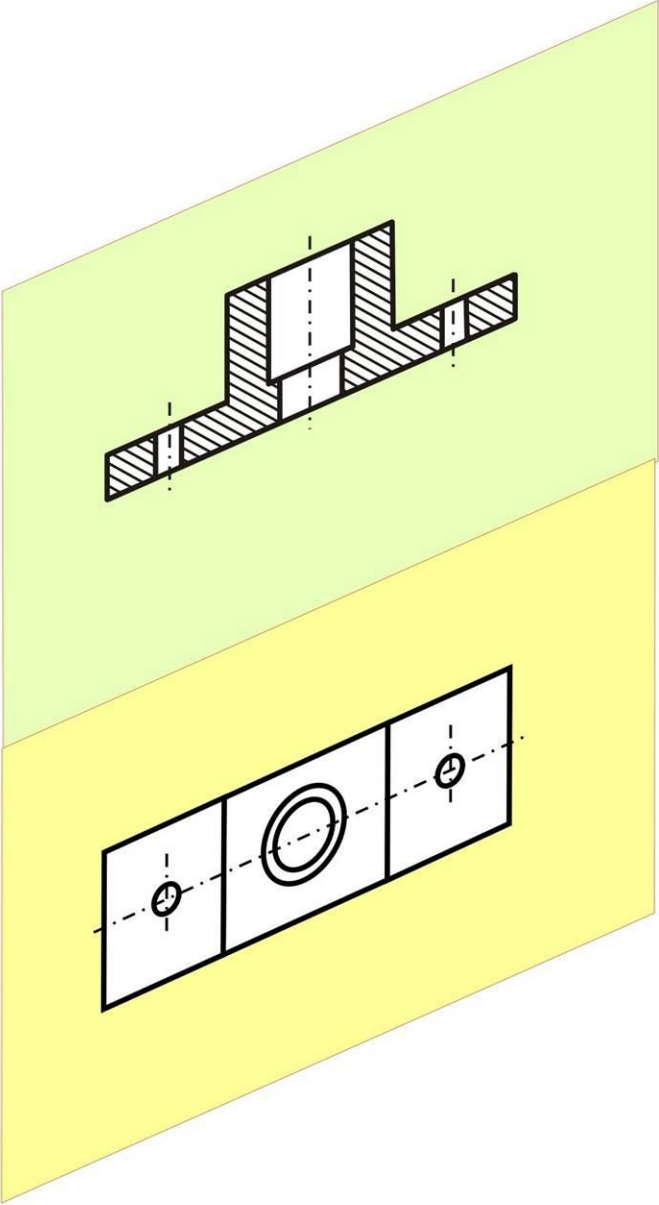

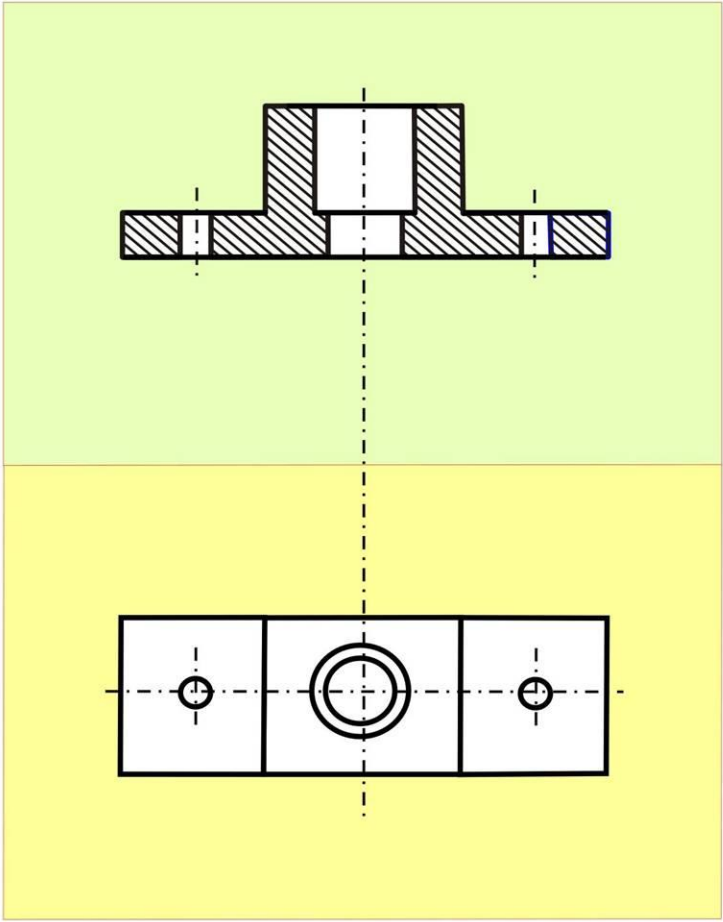

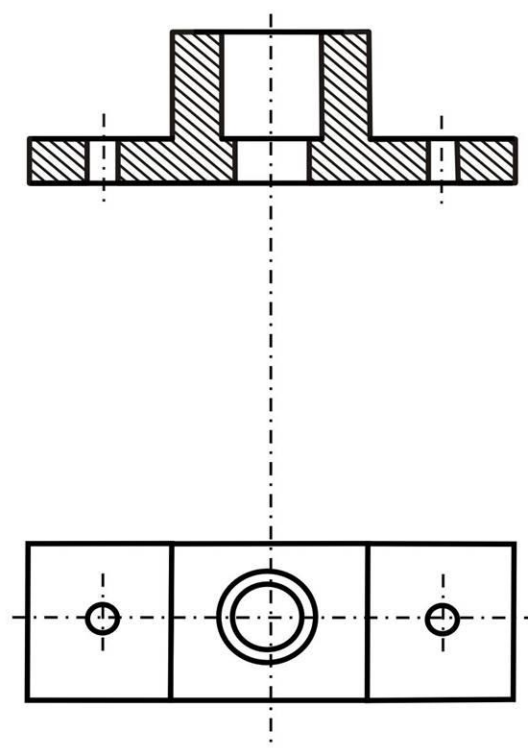



# A metszetkészítés lépései

1. Az alkatrész képzeletbeli elmetszése a metszősík mentén
2. Az elülső (nézőhöz közelebb álló) rész képzeletbeli elhagyása
3. A maradék rész ábrázolása nézetként
4. Az elmetszett anyag jelölése

# AZ ELMETSZETT TEST ANYAGMINŐSÉGÉNEK JELÖLÉSE

Fémes anyag



Üveg, plexi, átlátszó anyag



Szemcsés anyag



Folyadék



Műanyag, gumi



Fa keresztmetszete (bütü)



Fa hosszmetzete



Beton



# A SRAFFOZÁS SZABÁLYAI

# A sraffozás rajzolási szabályai

**Vonalvastagság:** Vékony (0,35 mm)

**Dőlésszög:** a kontúrhoz képest  $45^\circ$

**Vonalak sűrűsége:** 1-10 mm , a vastagvonalnak legalább kétszerese)

Egy alkatrész metszetei azonosan sraffozandók

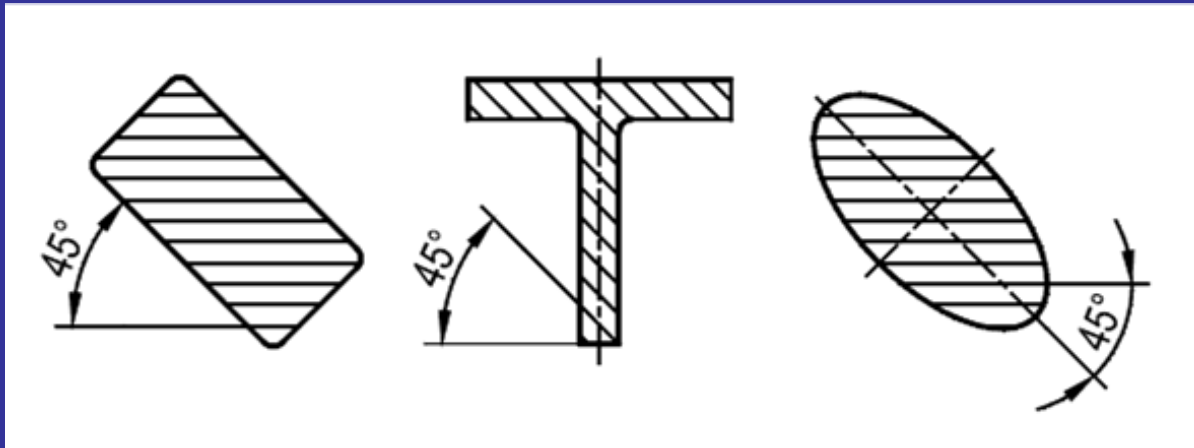

# Több látható alkatrész sraffozása

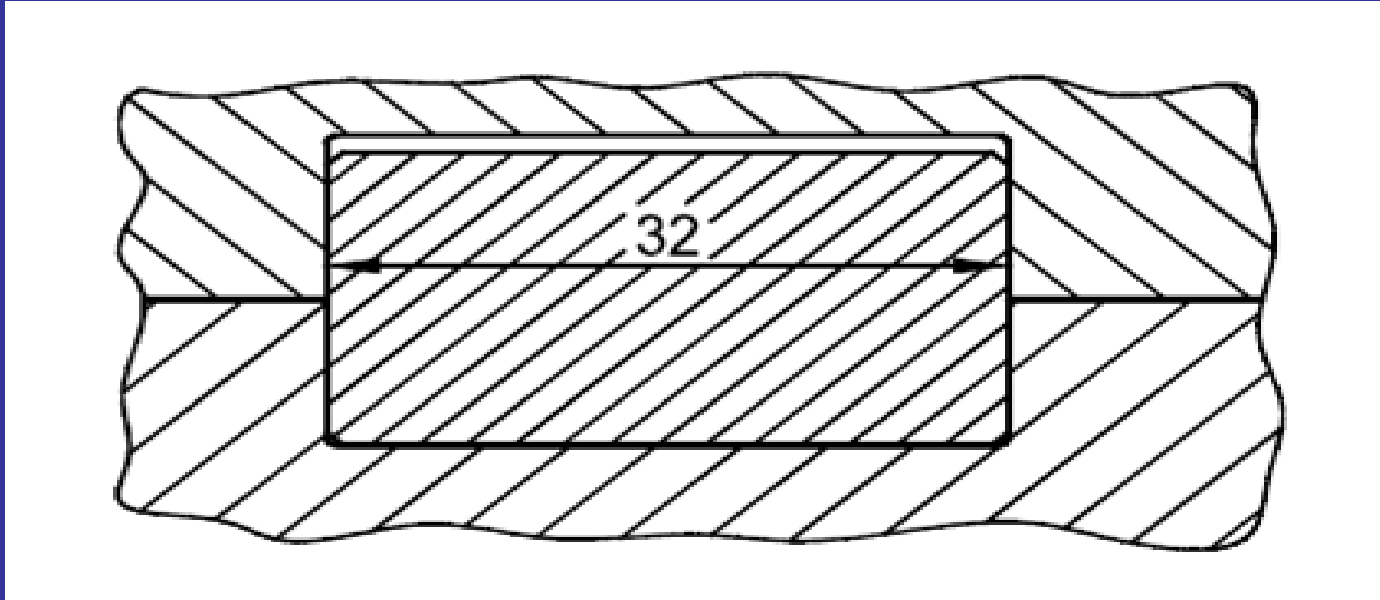

Csatlakozó alkatrészek vonalkázása:

különböző irányú

különböző sűrűségű

# Sraffozási egyszerűsítések

Nagy felületeket elegendő a kontúrvonal mentén vonalkázni

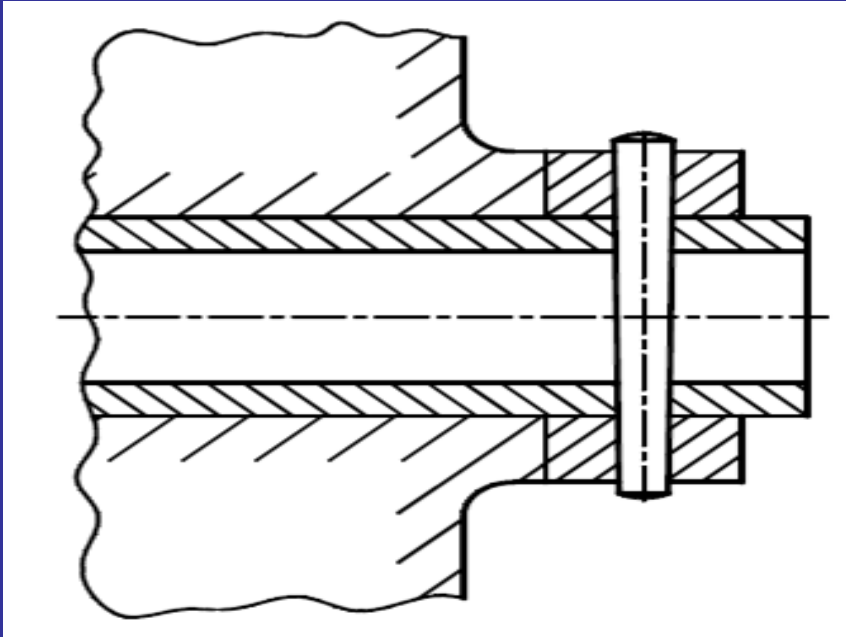

Vékony keresztmetszeteket feketíteni kell. (Köztük 0,7 mm-es rés hagyandó)



# A METSZETEK HELYÉNEK JELÖLÉSE



# Nem kell jelölni a nyomvonalat, ha

- a metszősík szimmetriasík,
- csak egy metszet készül a tárgyról,
- a metszetet a vetületrendnek megfelelően helyezzük el.

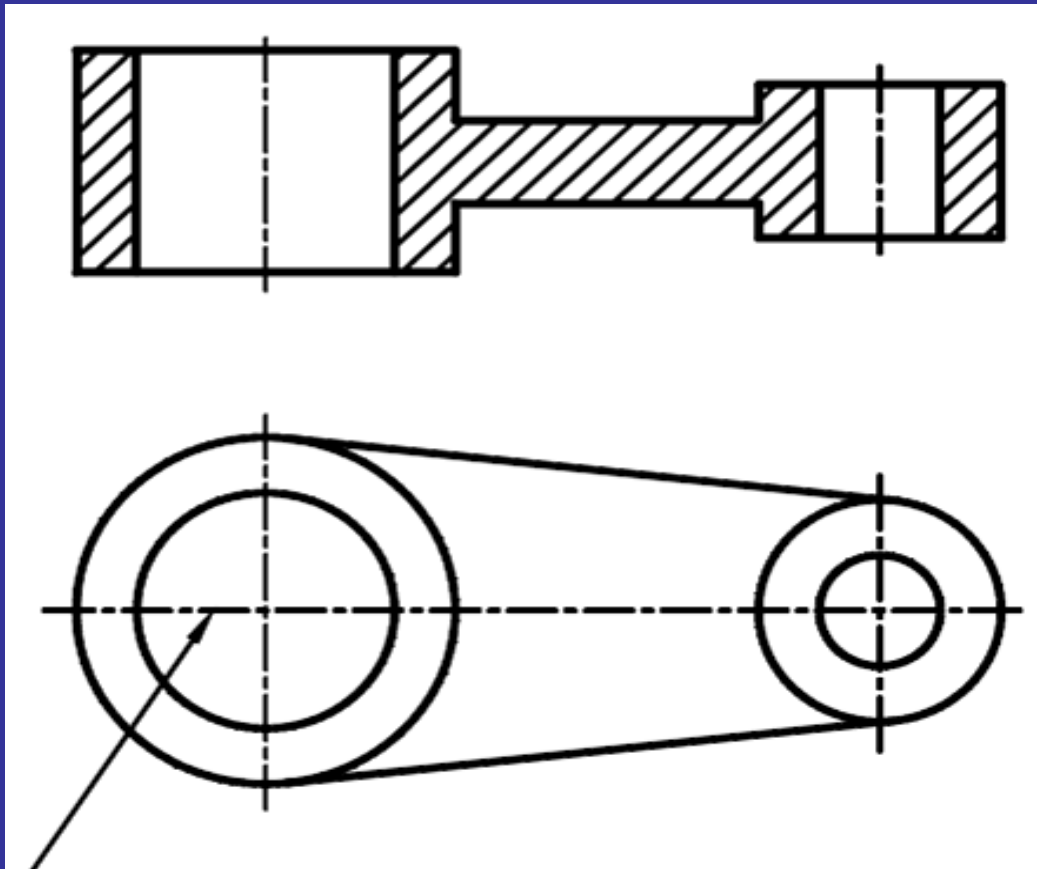

# Jelölni kell a nyomvonalat, ha

- a metszősík helye nem egyértelmű, vagy
- több metszősík van.

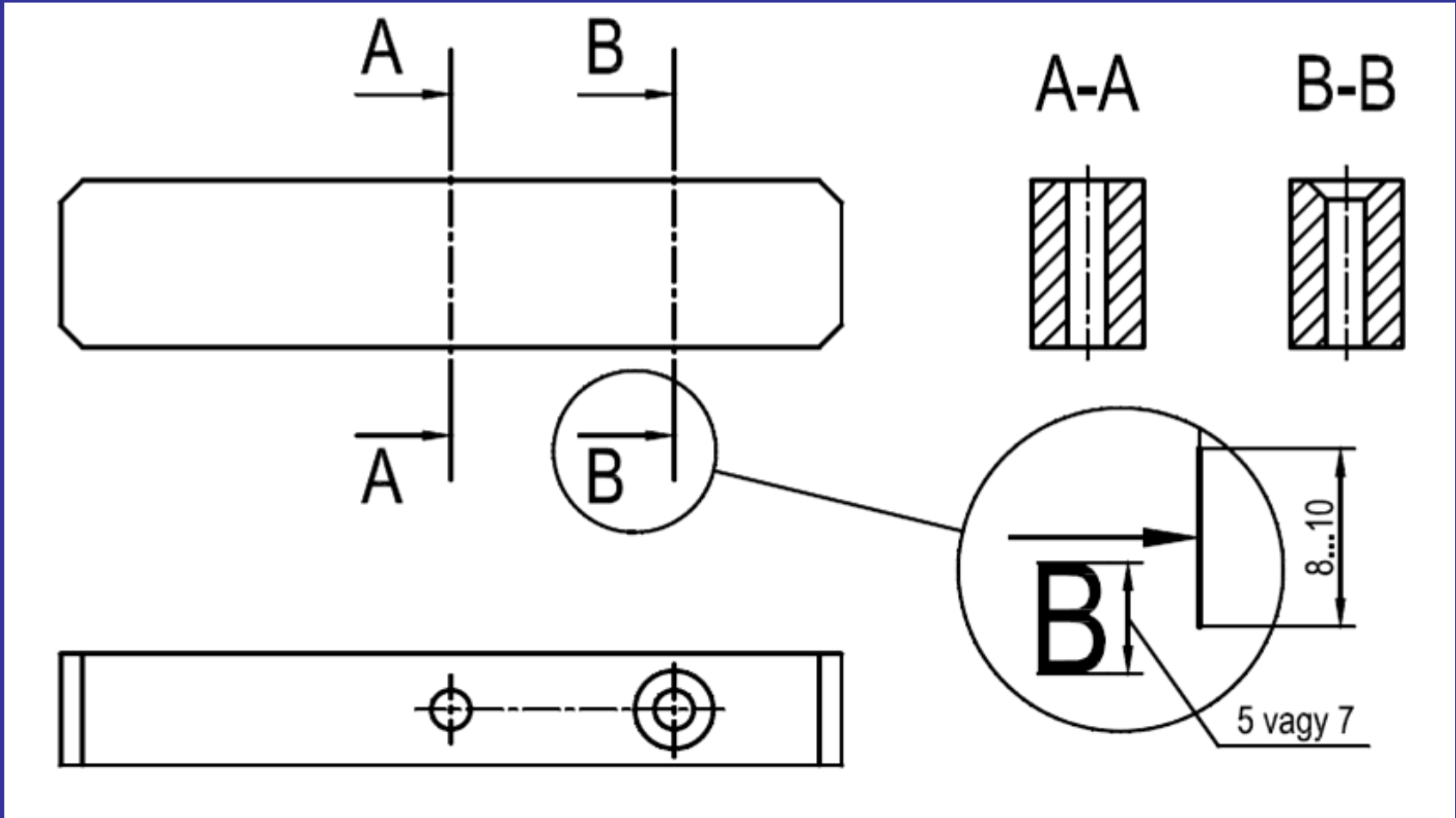

# A METSZETEK FAJTÁI

# Teljes metszet

Vetítési irányban elhelyezett metszet

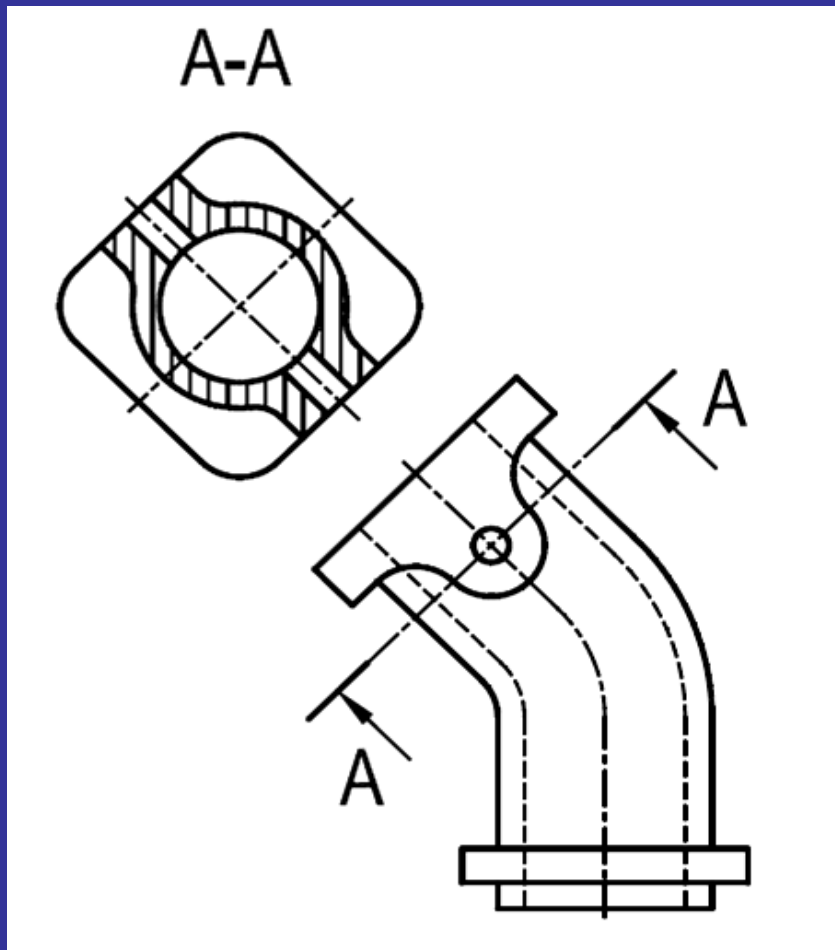

Nem vetítési irányban elhelyezett metszet

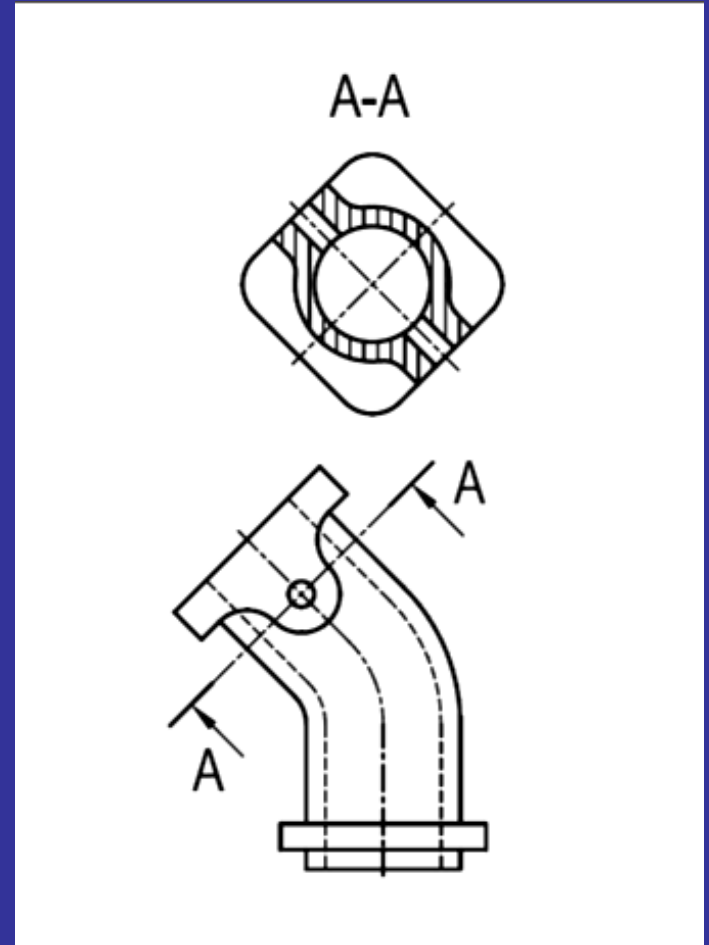

# Teljes metszet elforgatva

A-A

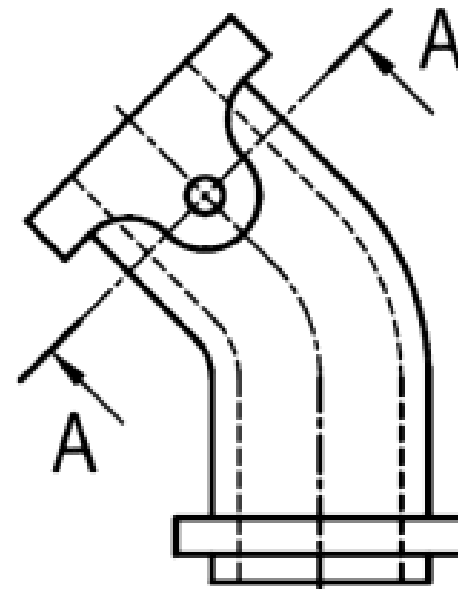
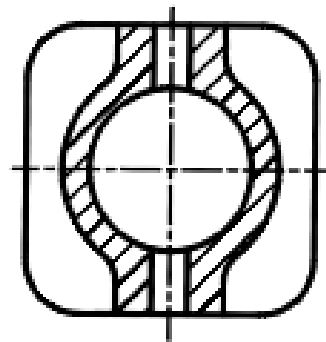

# Félmetszet

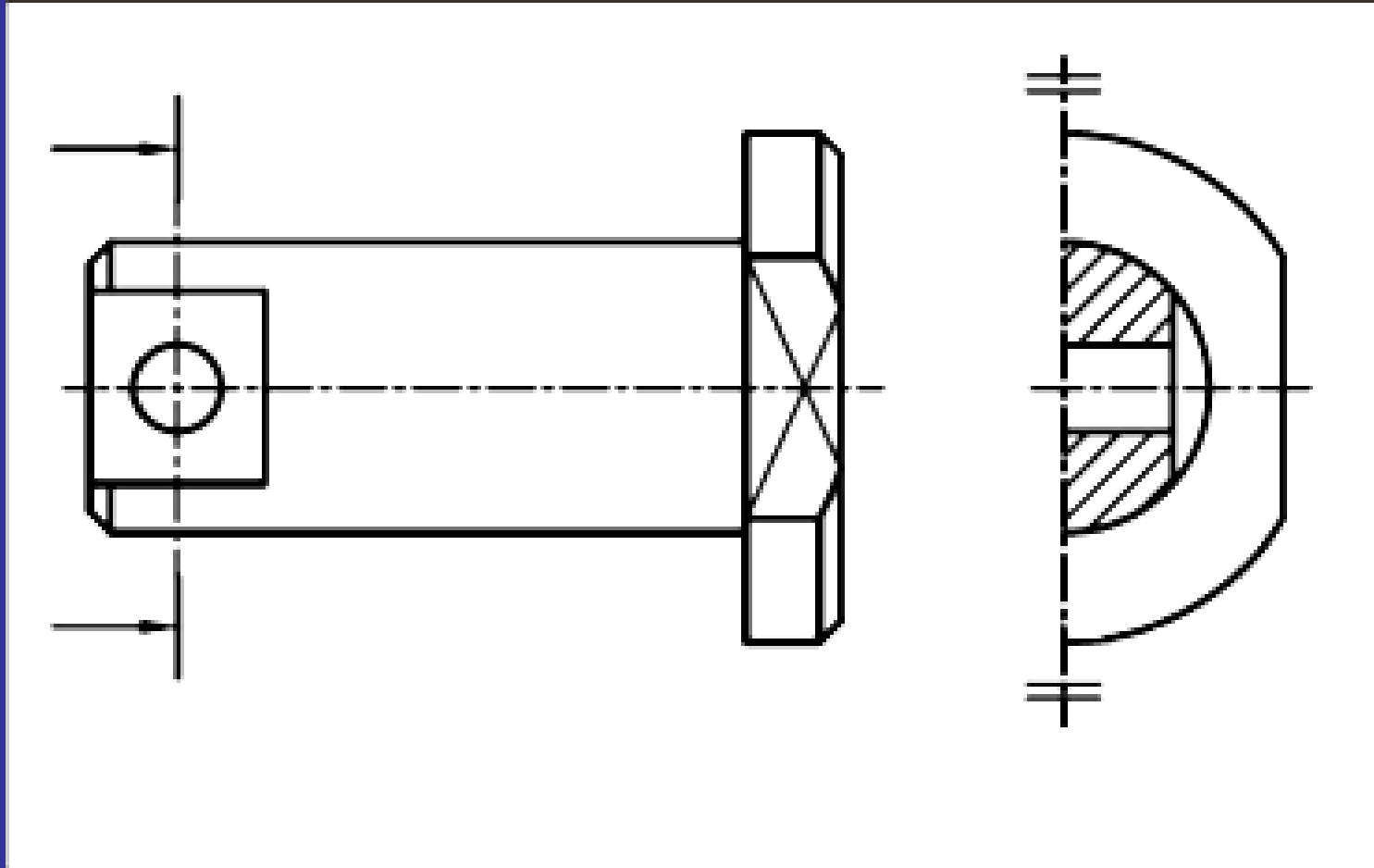

# Félnézet-félmetszet

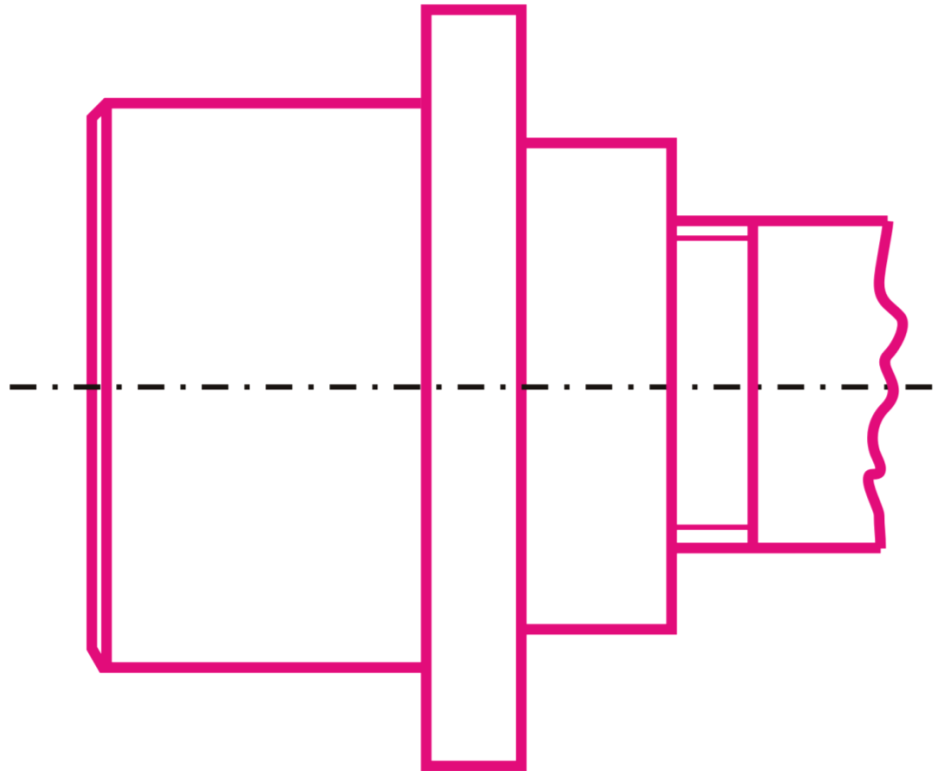

# Félnézet-félmetszet

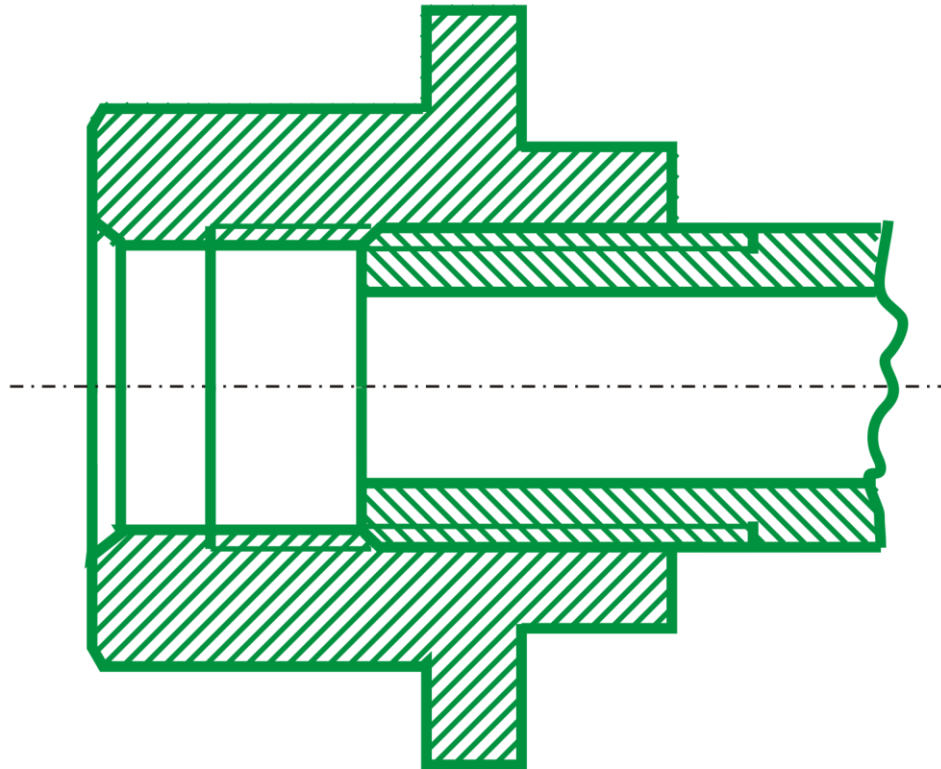



# Félnézet-félmetszet

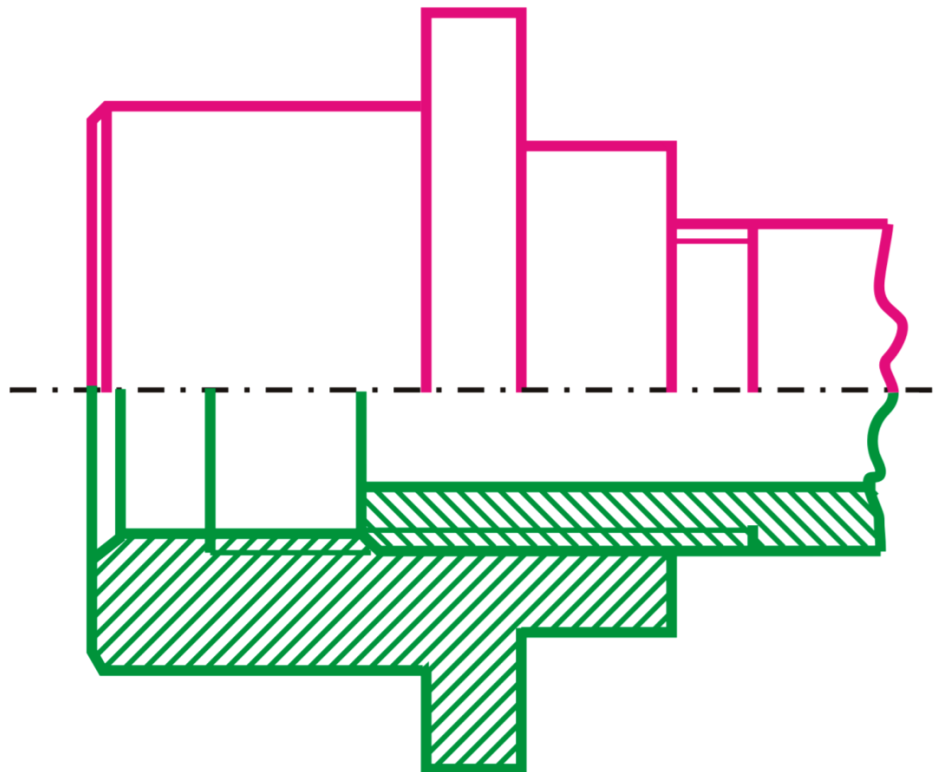

# Félnézet-félmetszet

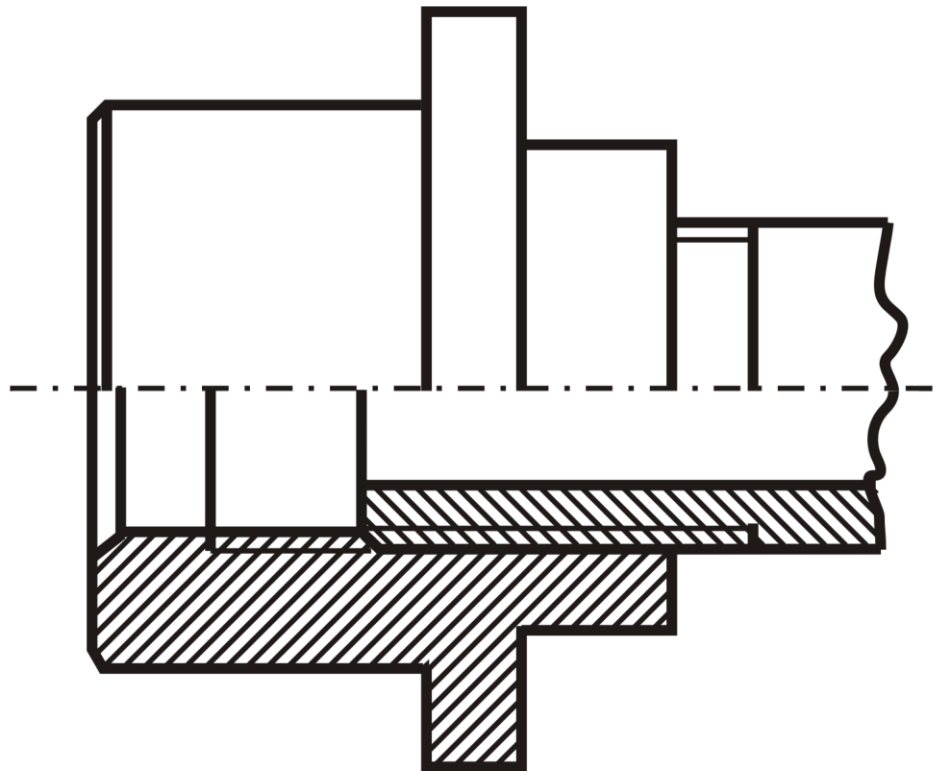

# Metszetkészítés, ha a szimmetriatengelyre látható él esik

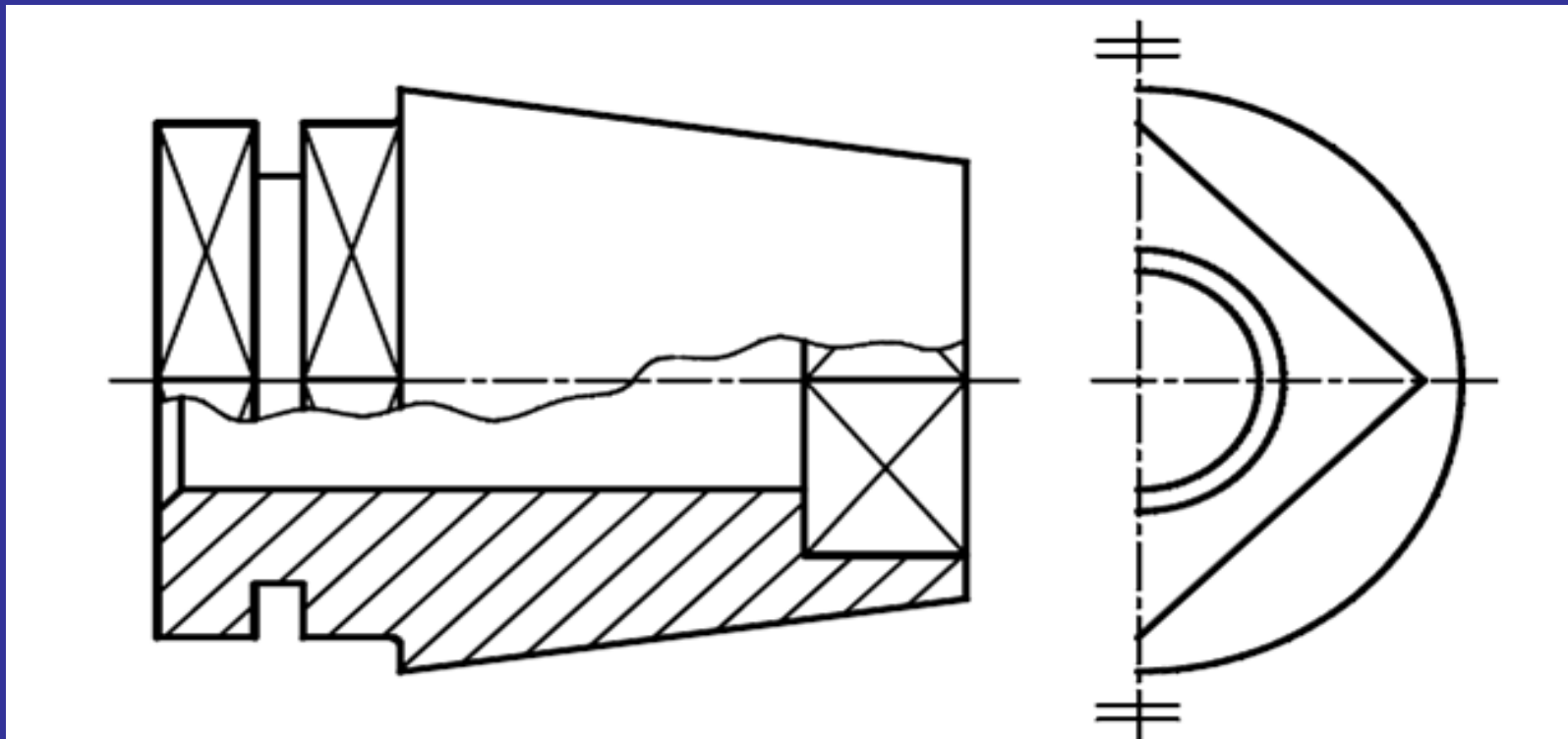

# Kitörés

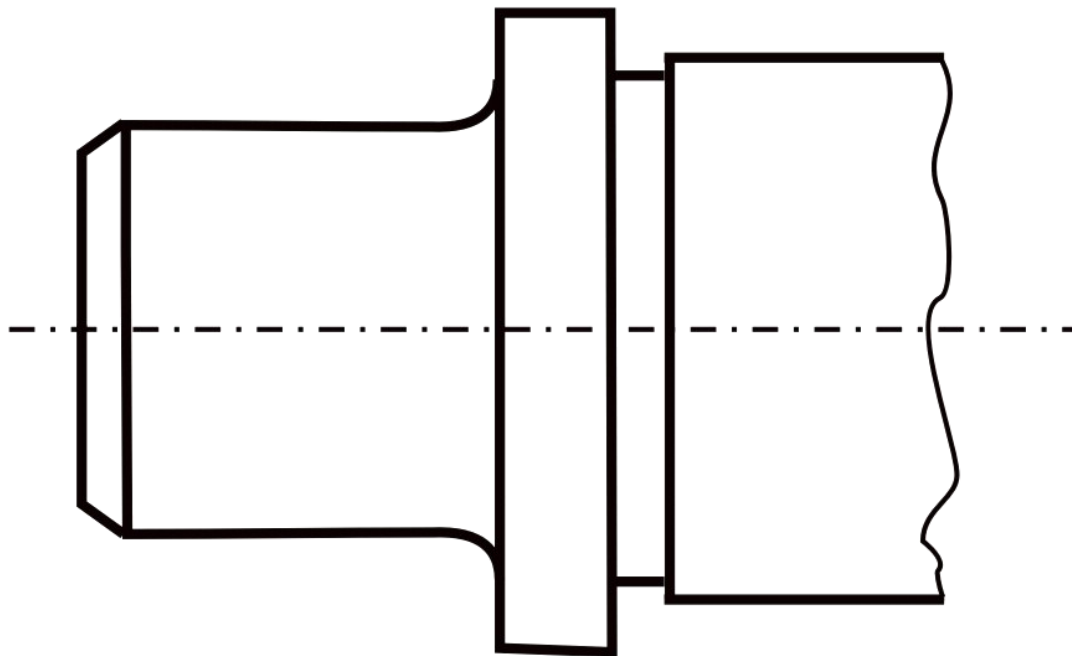

# Kitörés

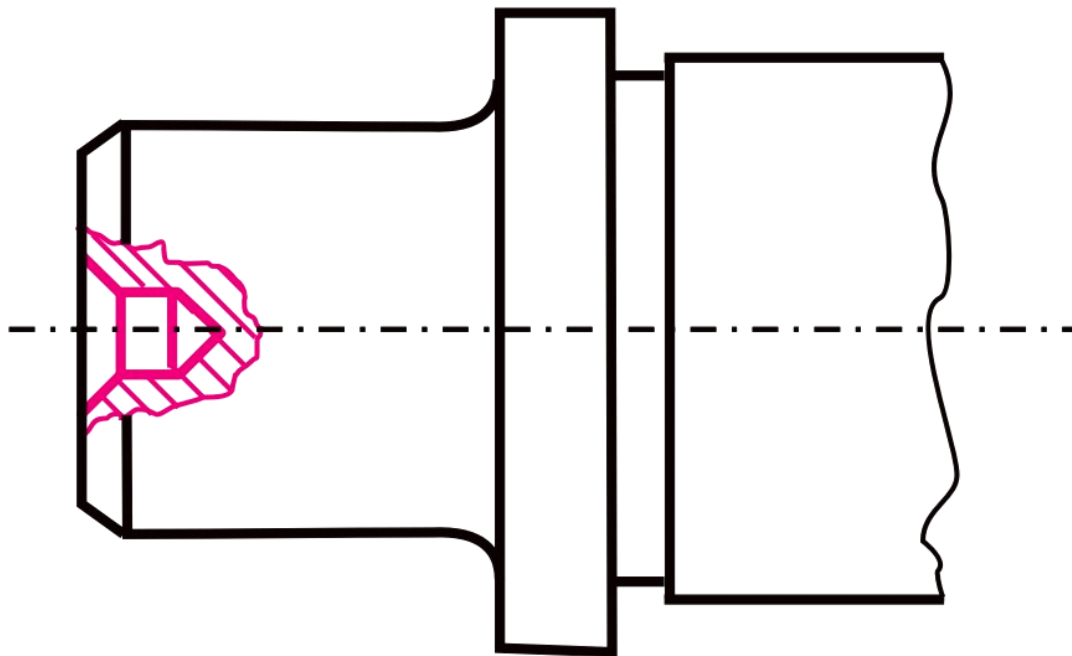

# Kitörés

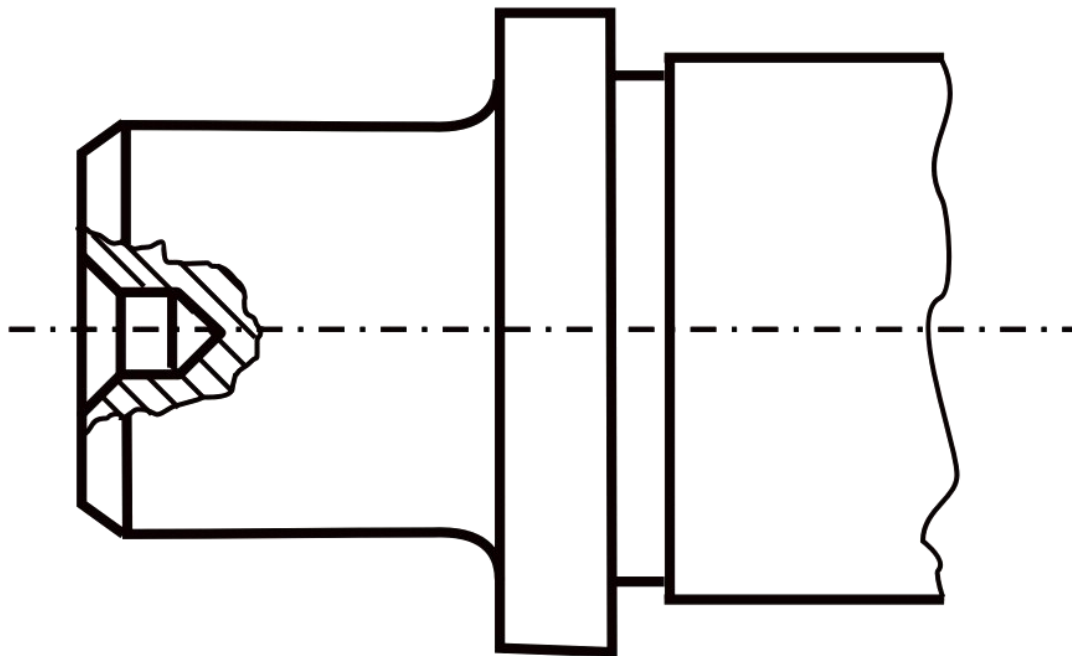

# Lépcsős metszet

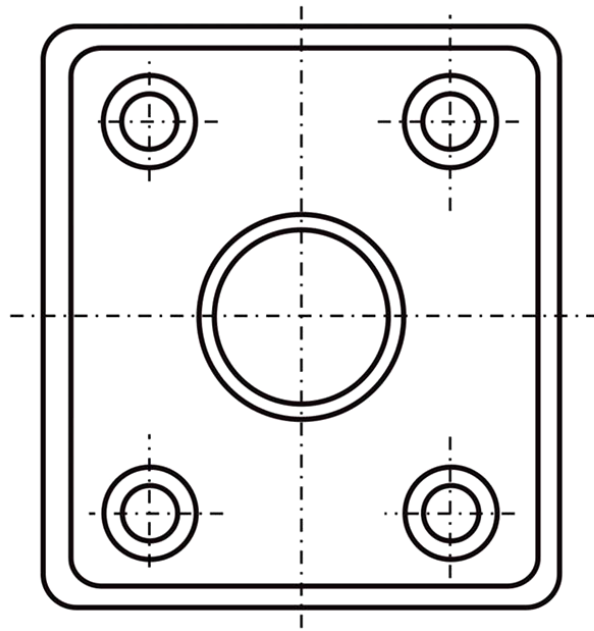

# Lépcsős metszet

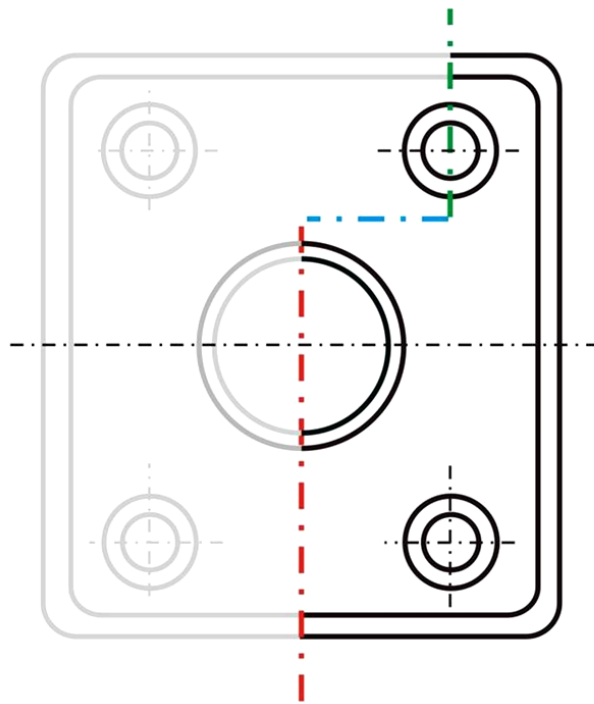



# Lépcsős metszet

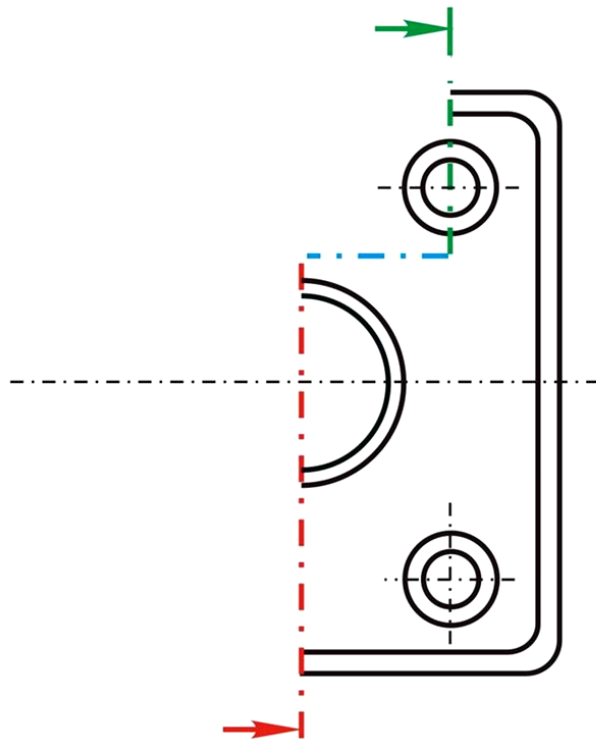

# Lépcsős metszet

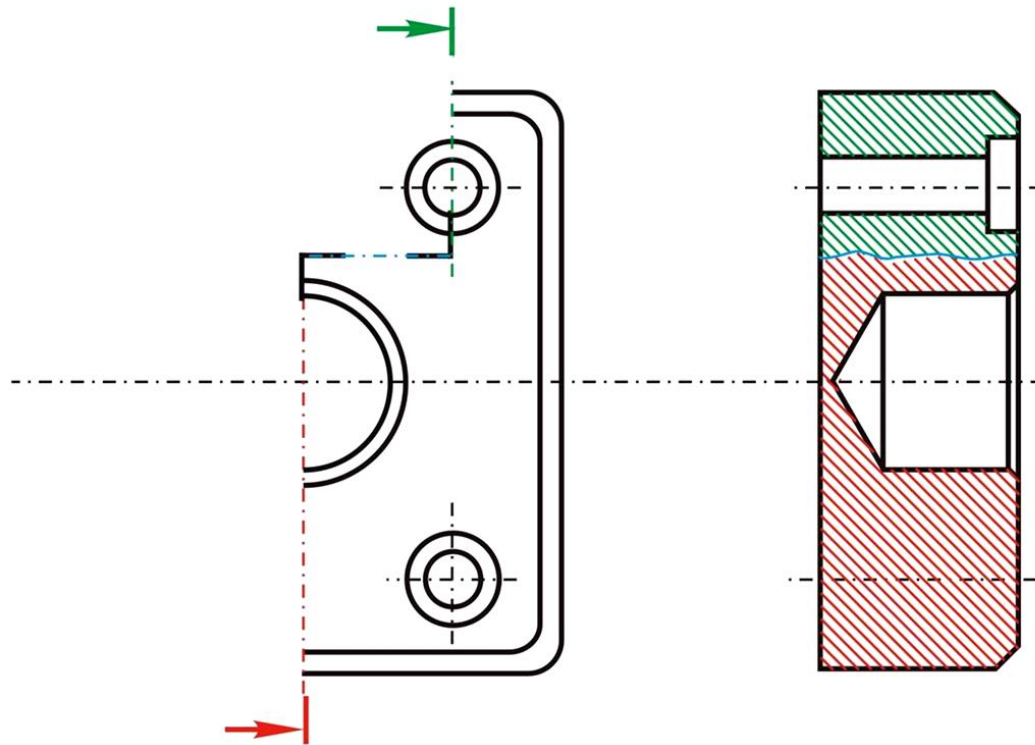

# Lépcsős metszet

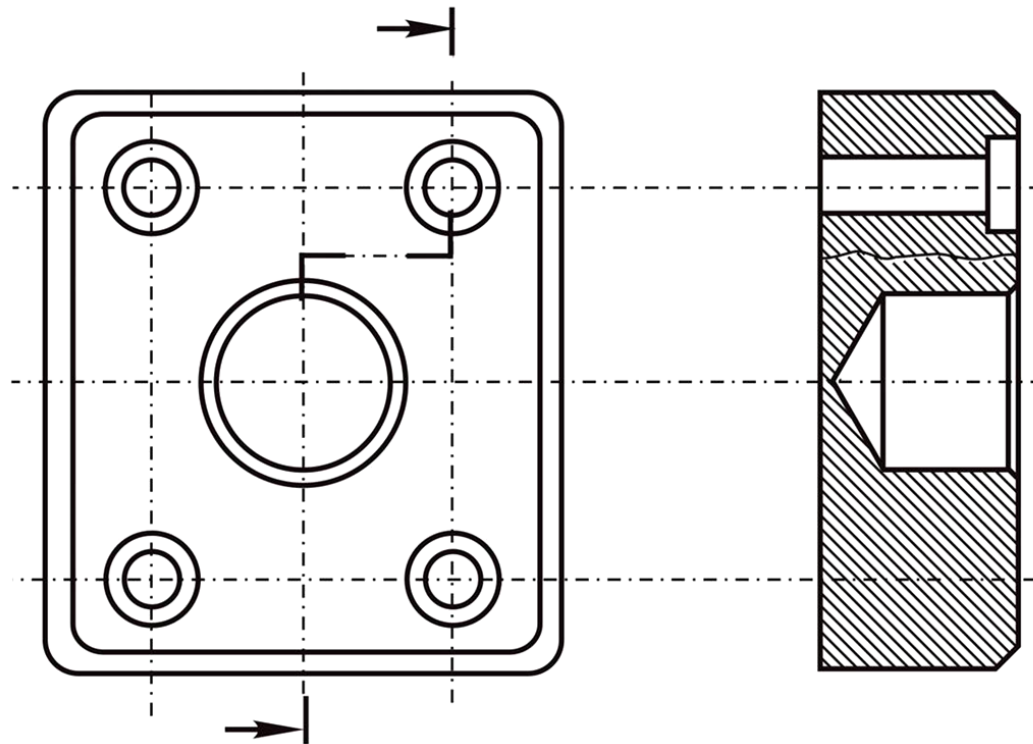

# Beforgatott metszet

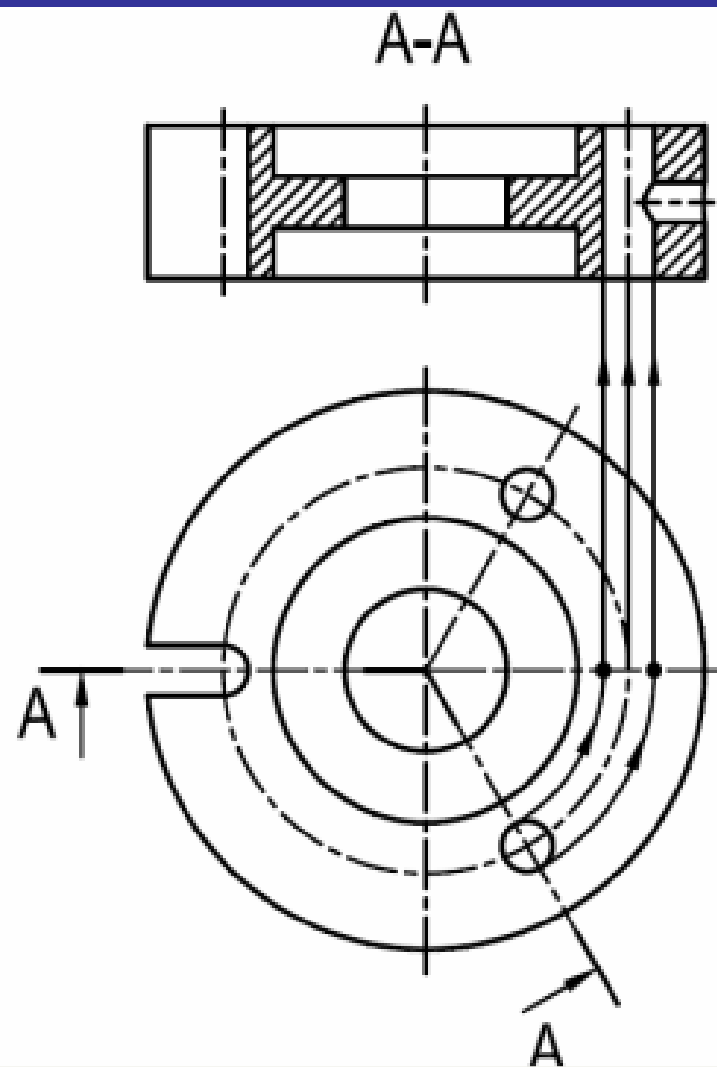
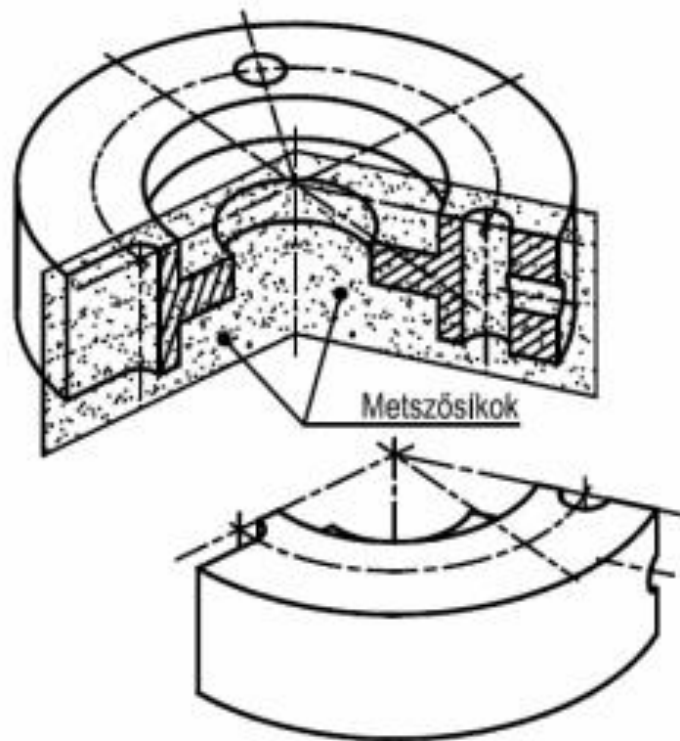

# METSZÉSI TILALMAK

# Hossztengelyükkel párhuzamosan nem metszhető alkatrészek

Csavar

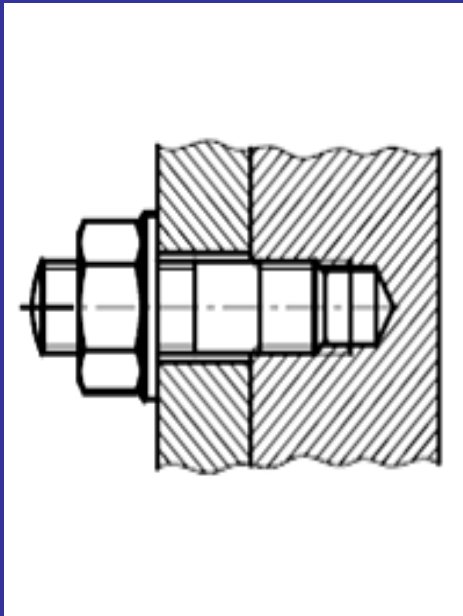

Csapszeg

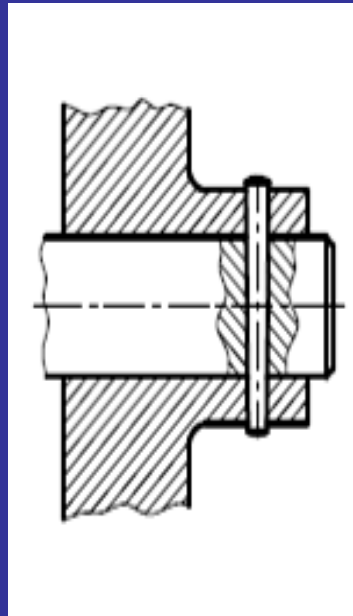

Ék, retesz

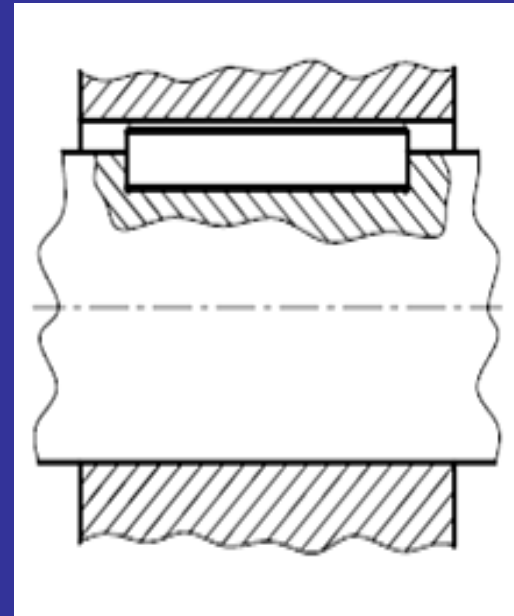

Szegecs

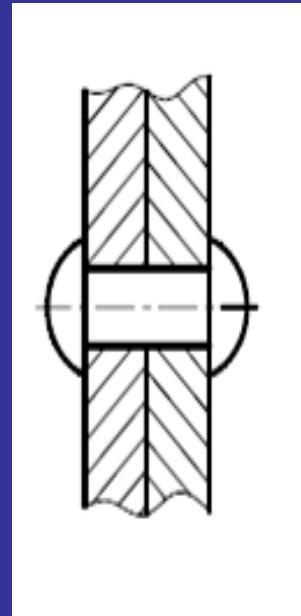

# SZELVÉNYEK

# A szelvénykészítés célja:

az alkatrész metszősíkra eső geometriai alakjának ábrázolása



# A SZELVÉNYEK SZÁRMAZTATÁSA

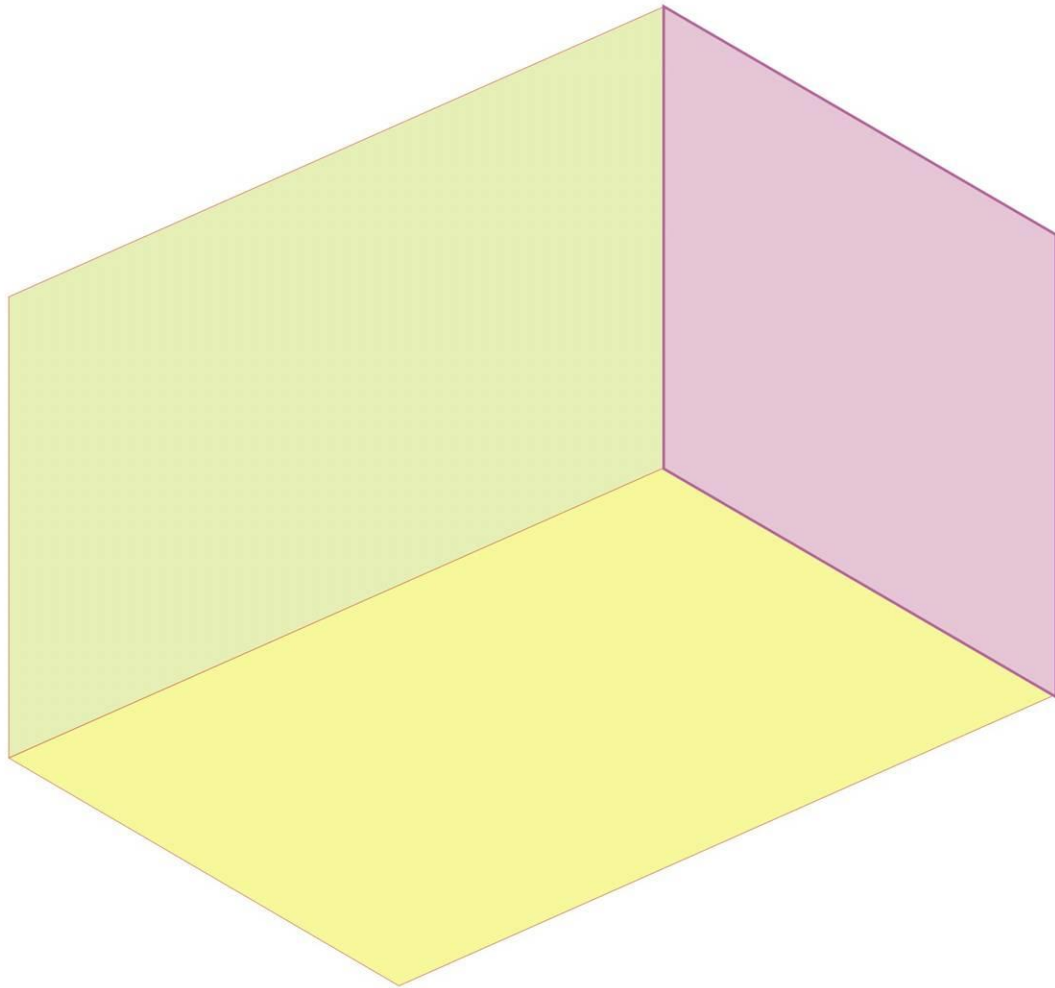

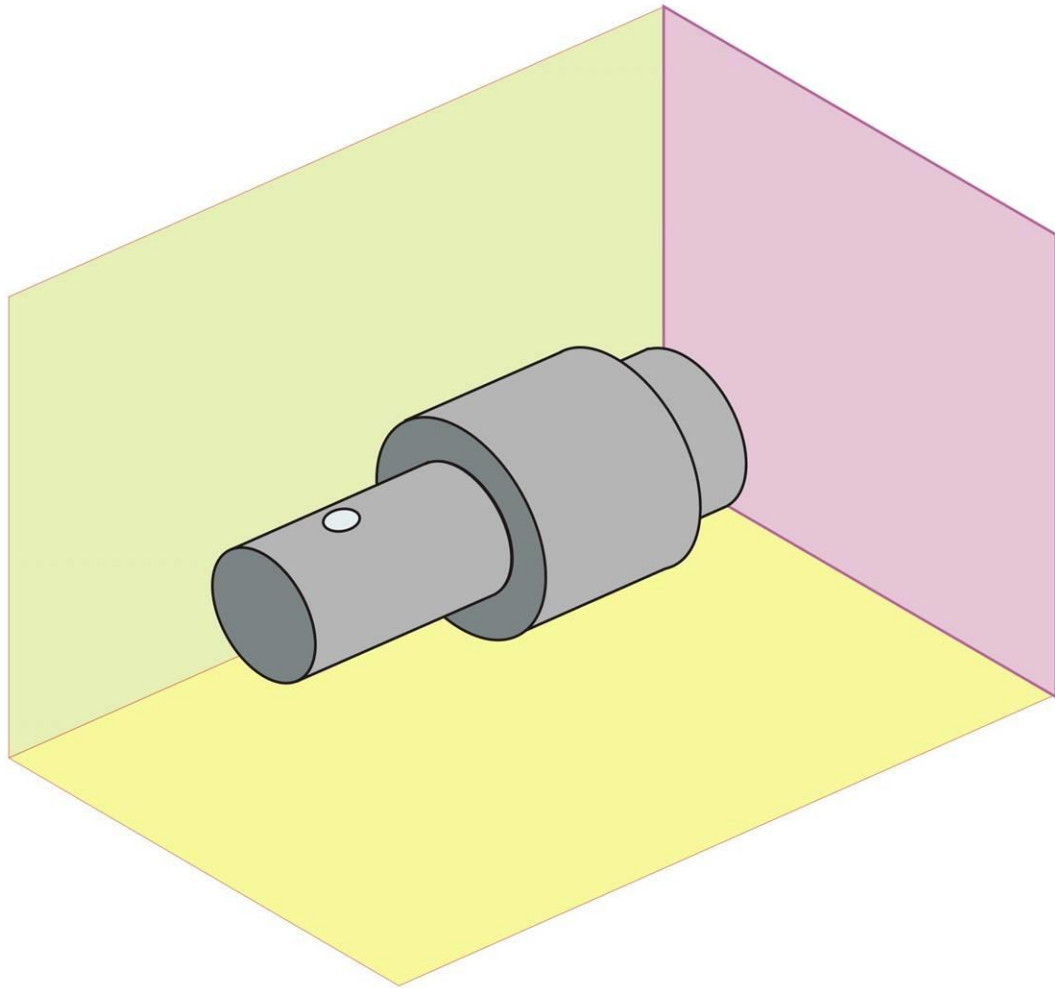

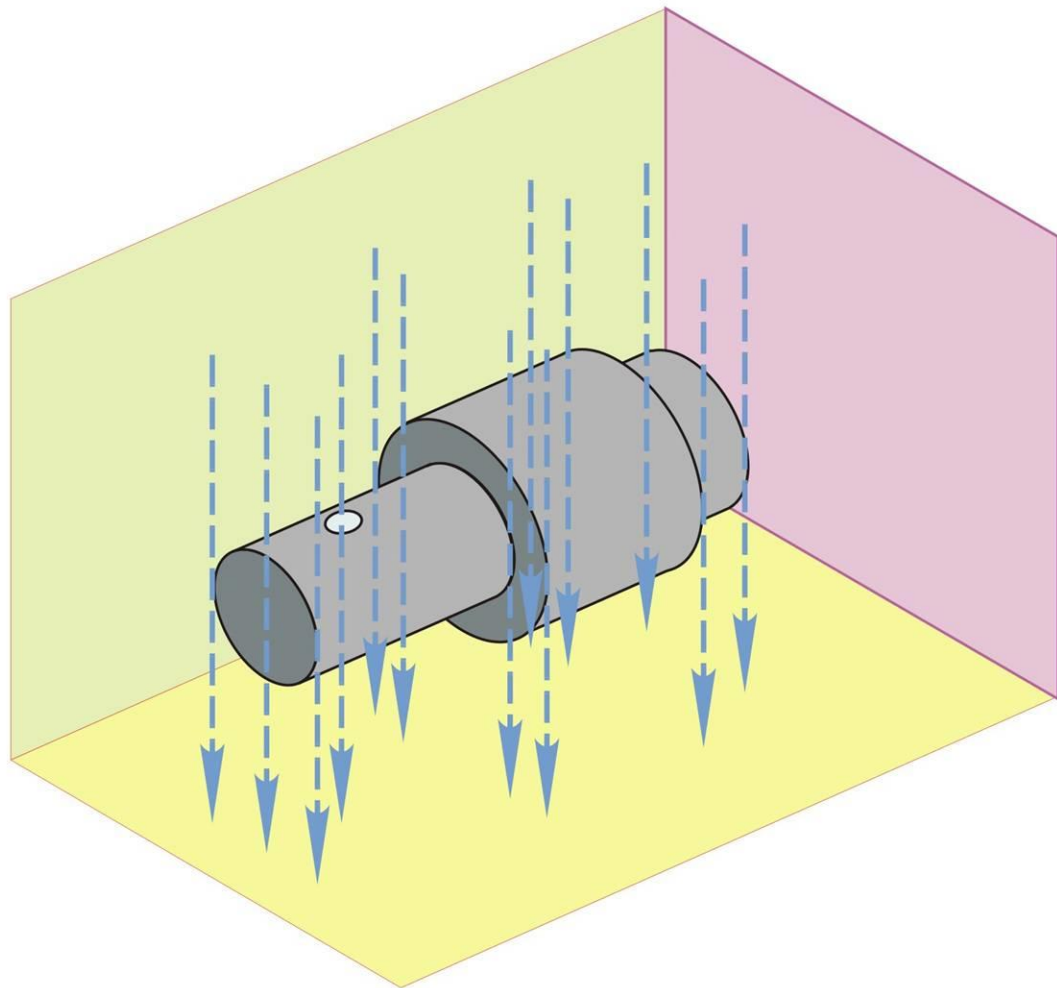

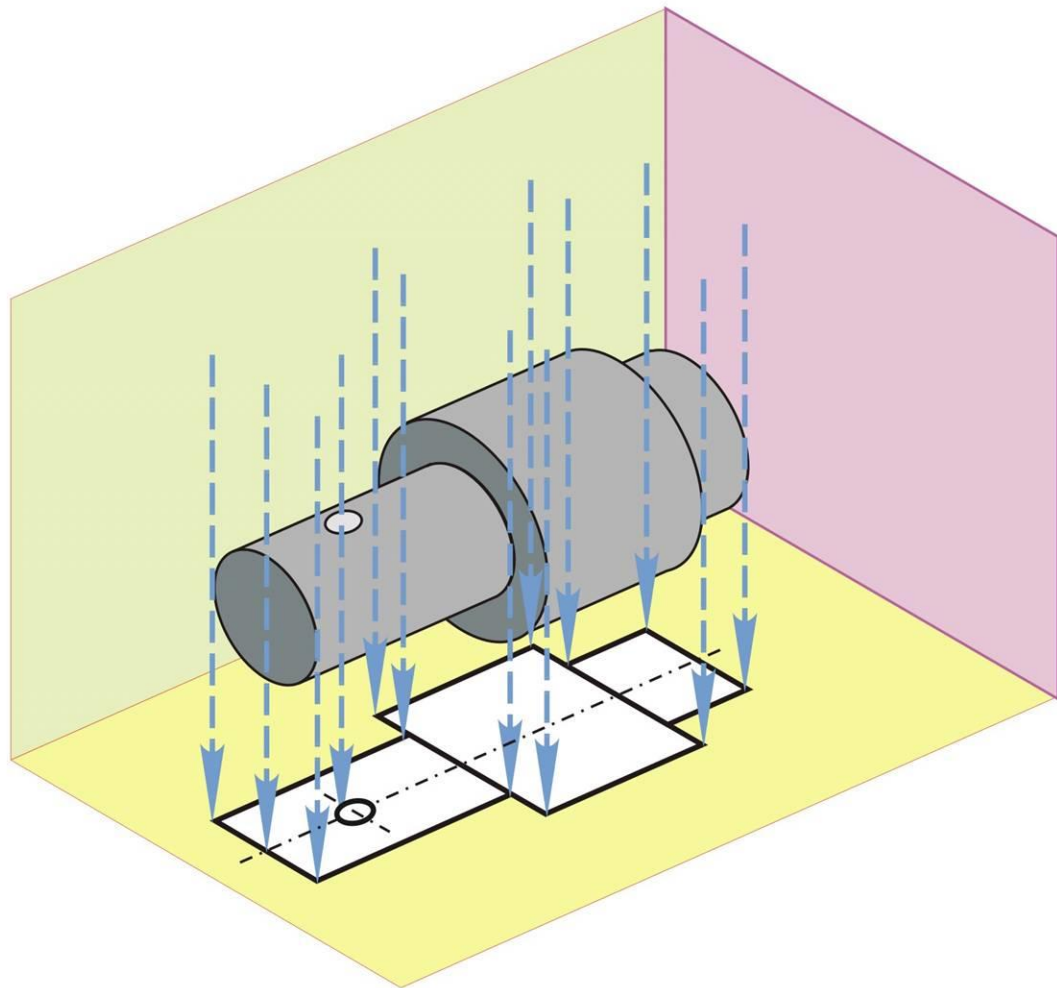

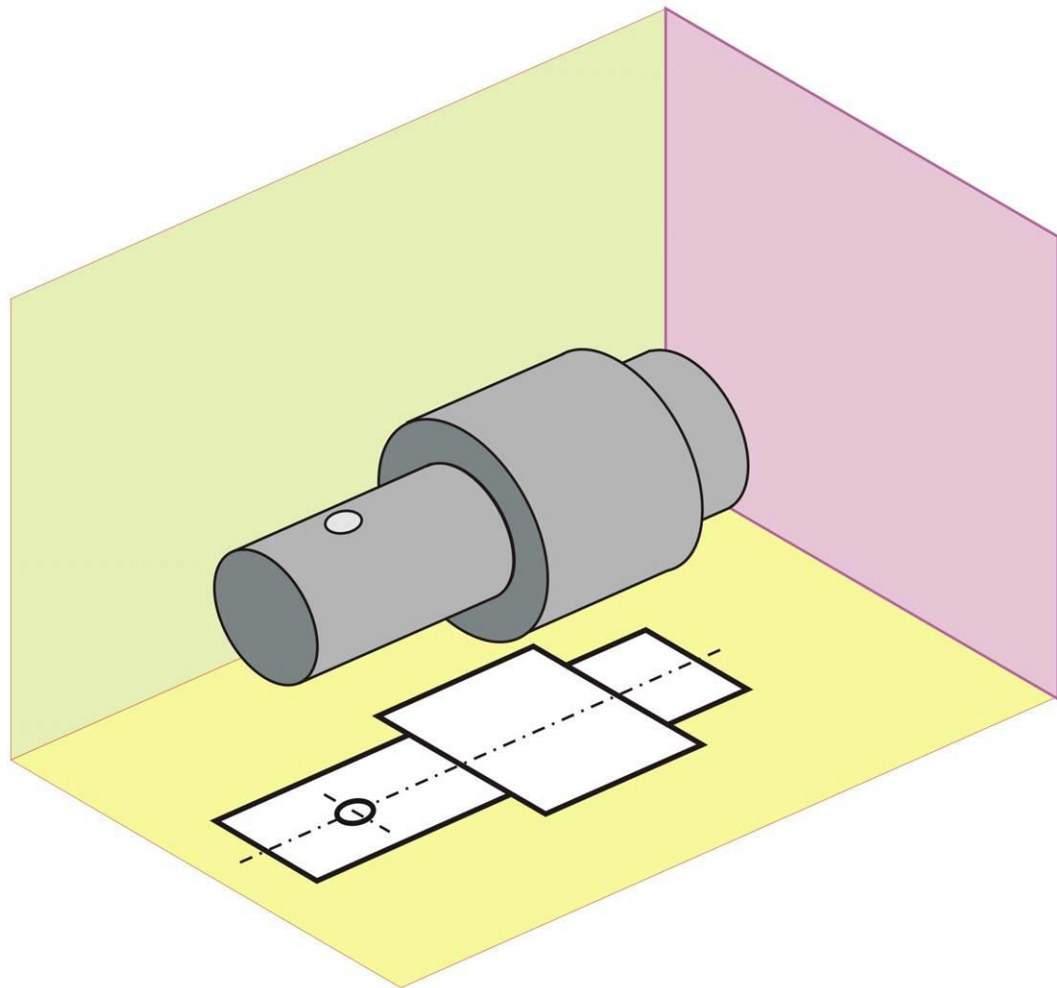

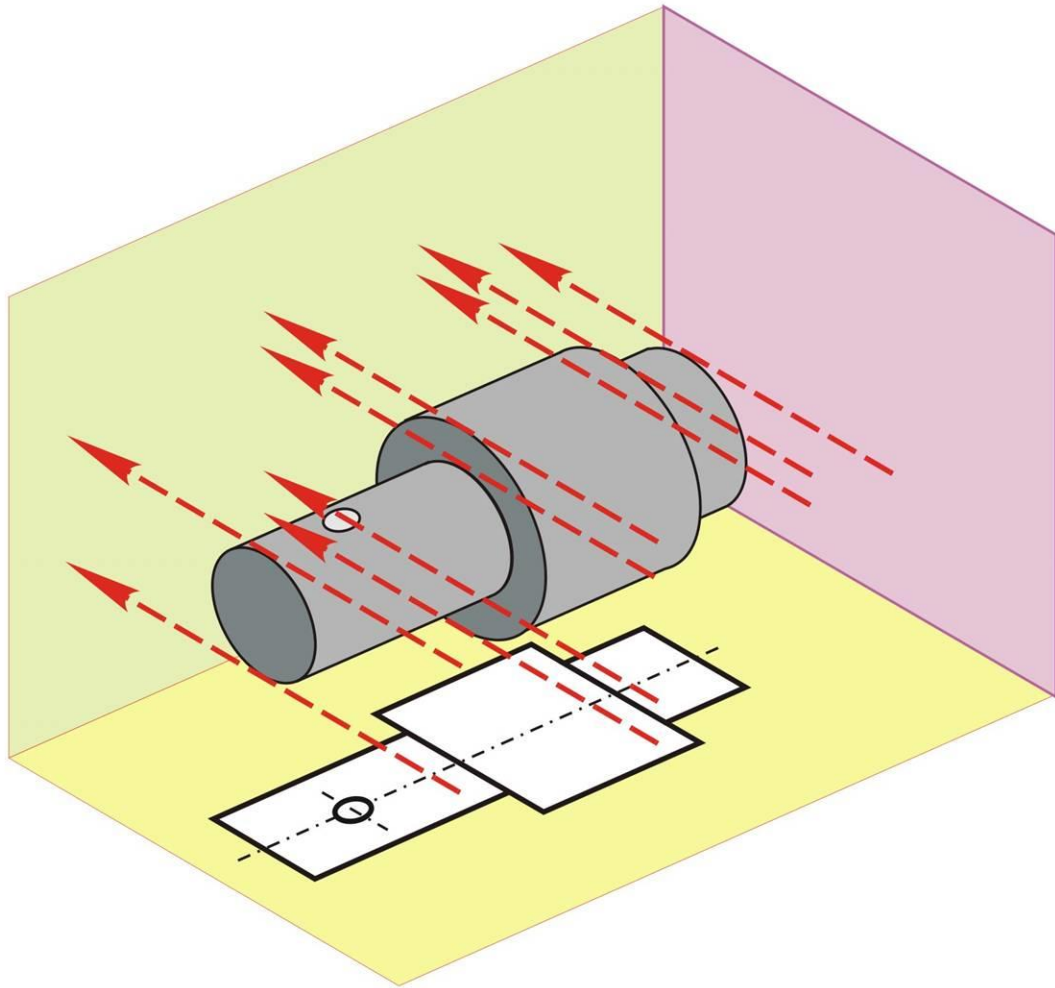

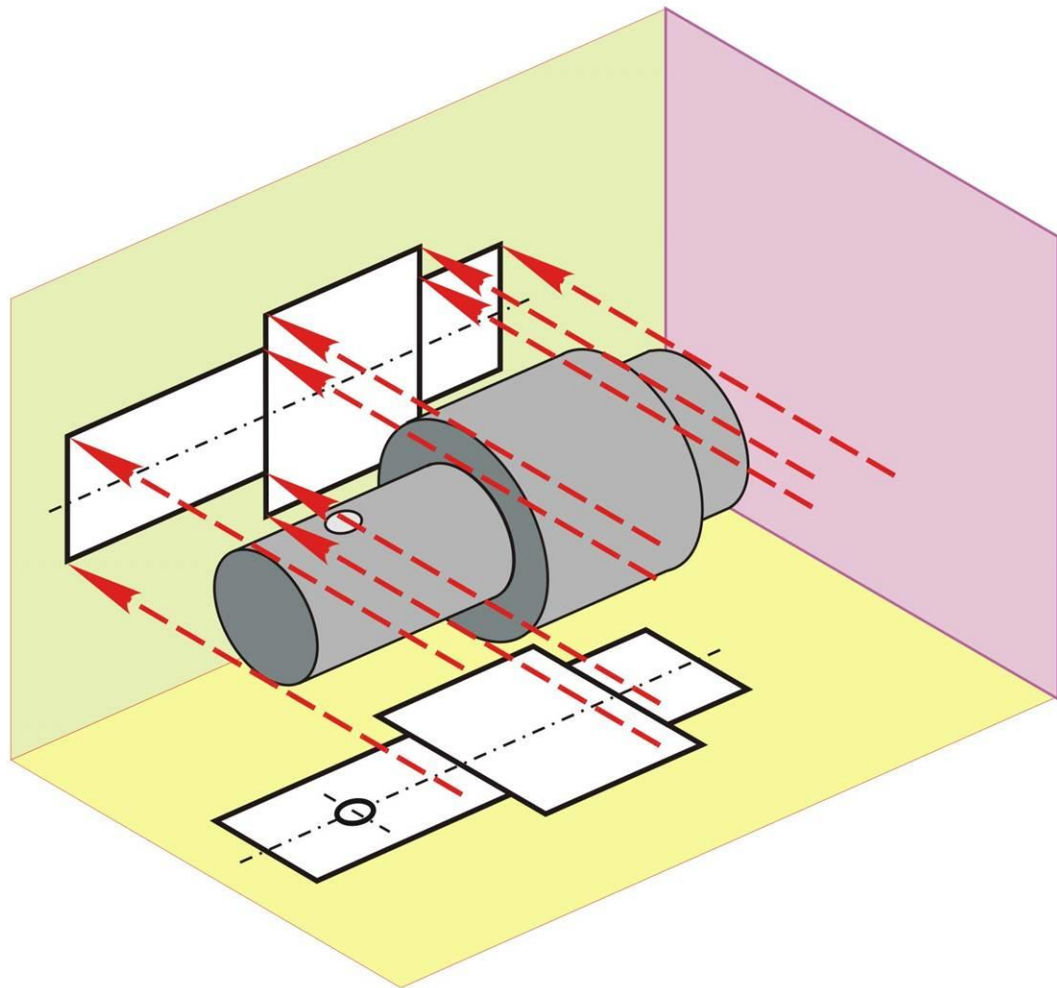



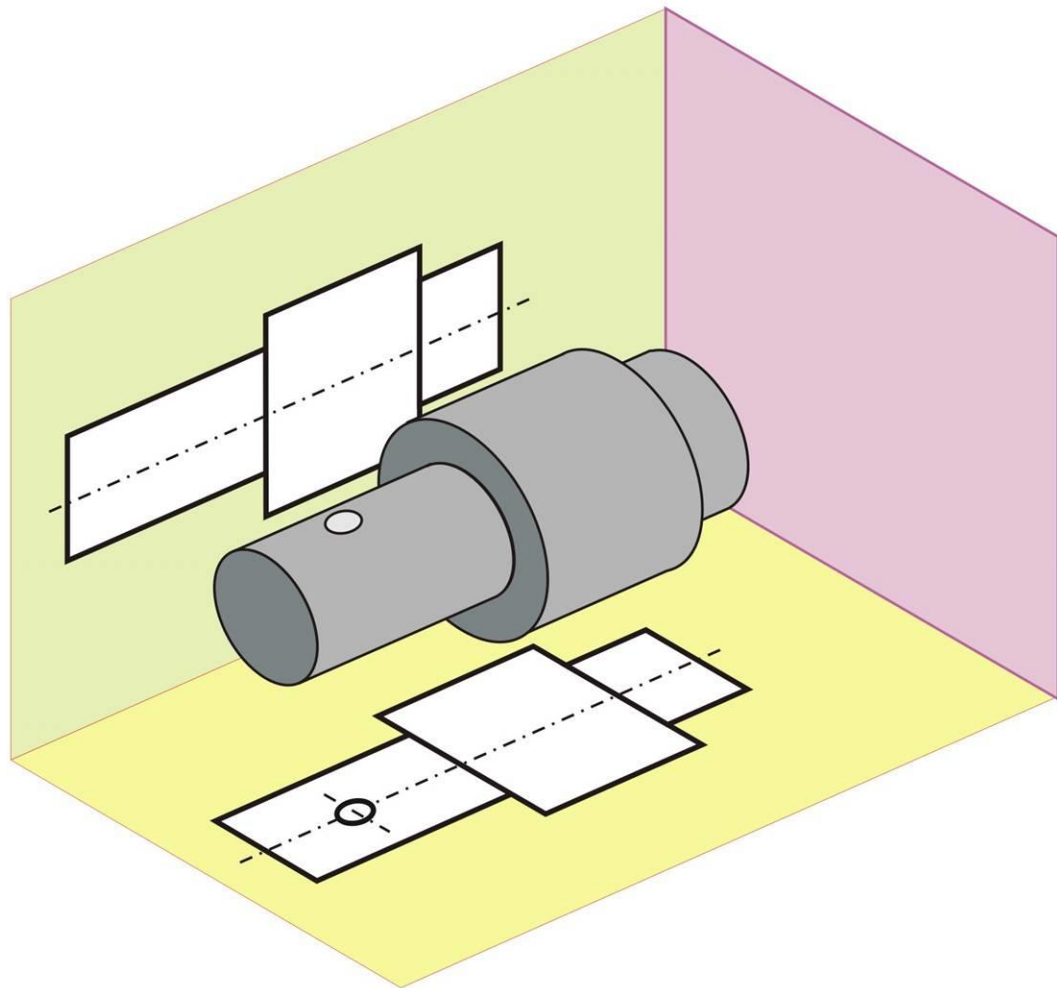

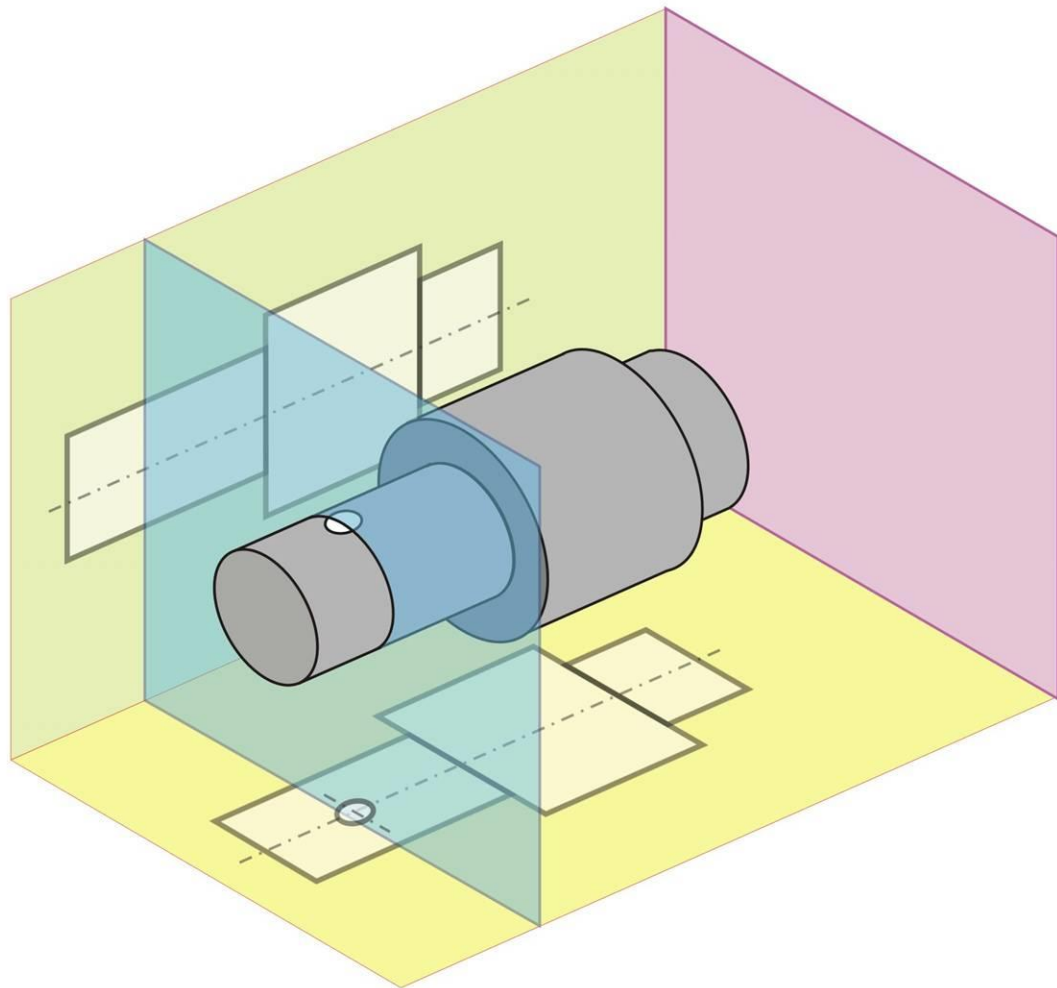

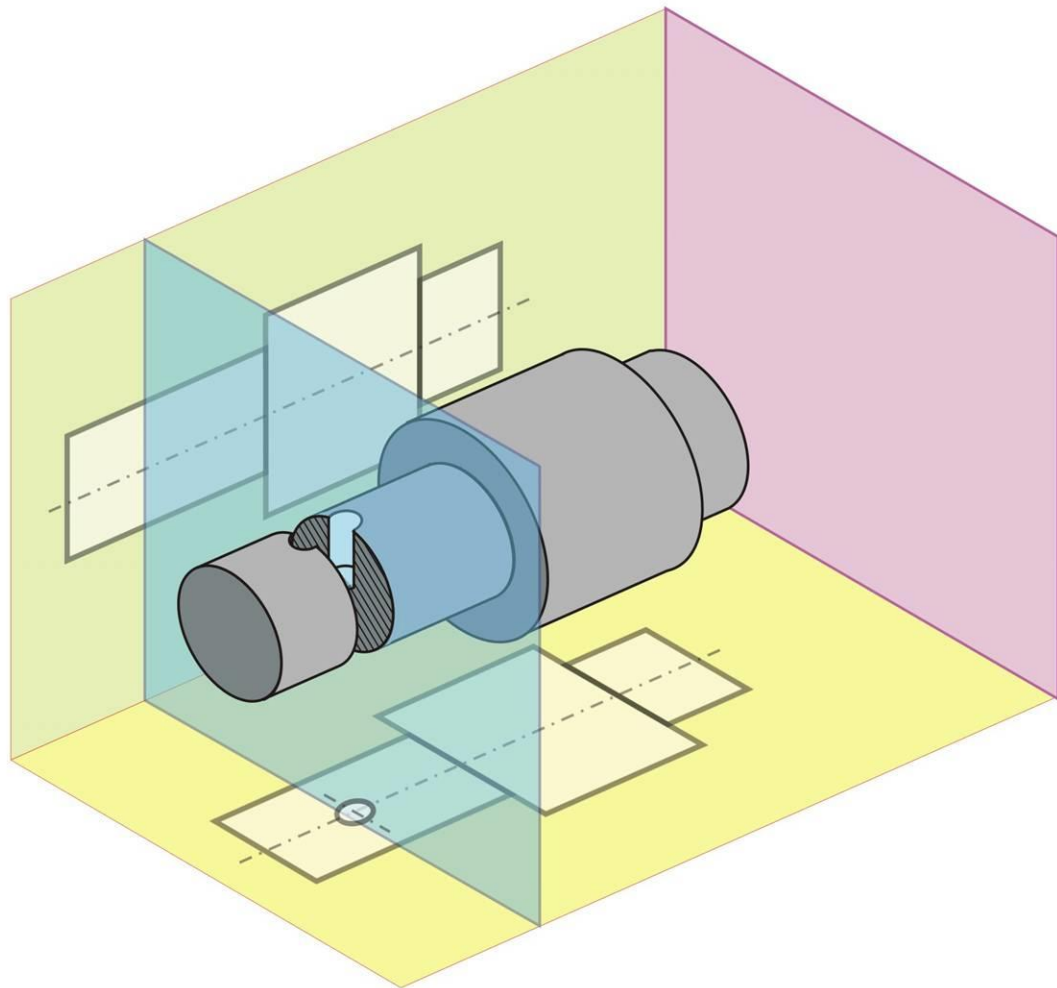

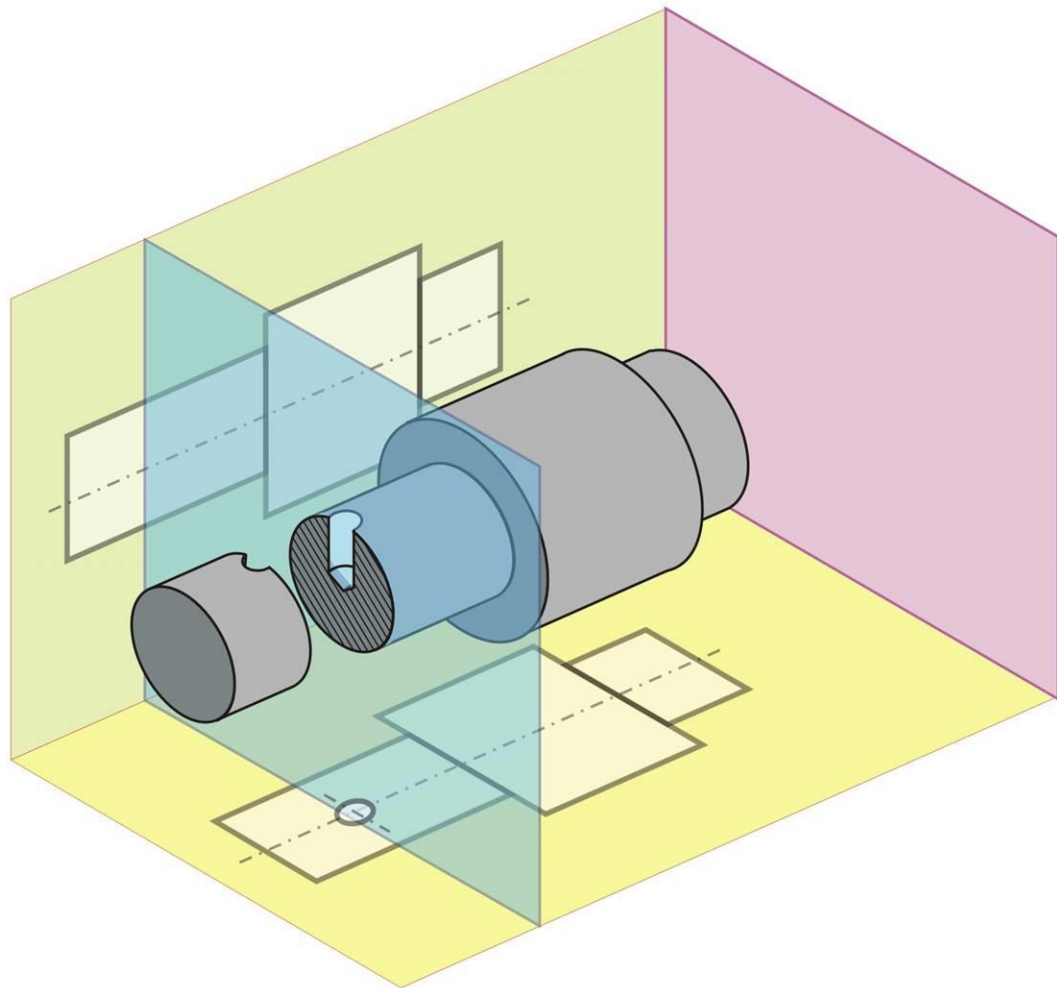

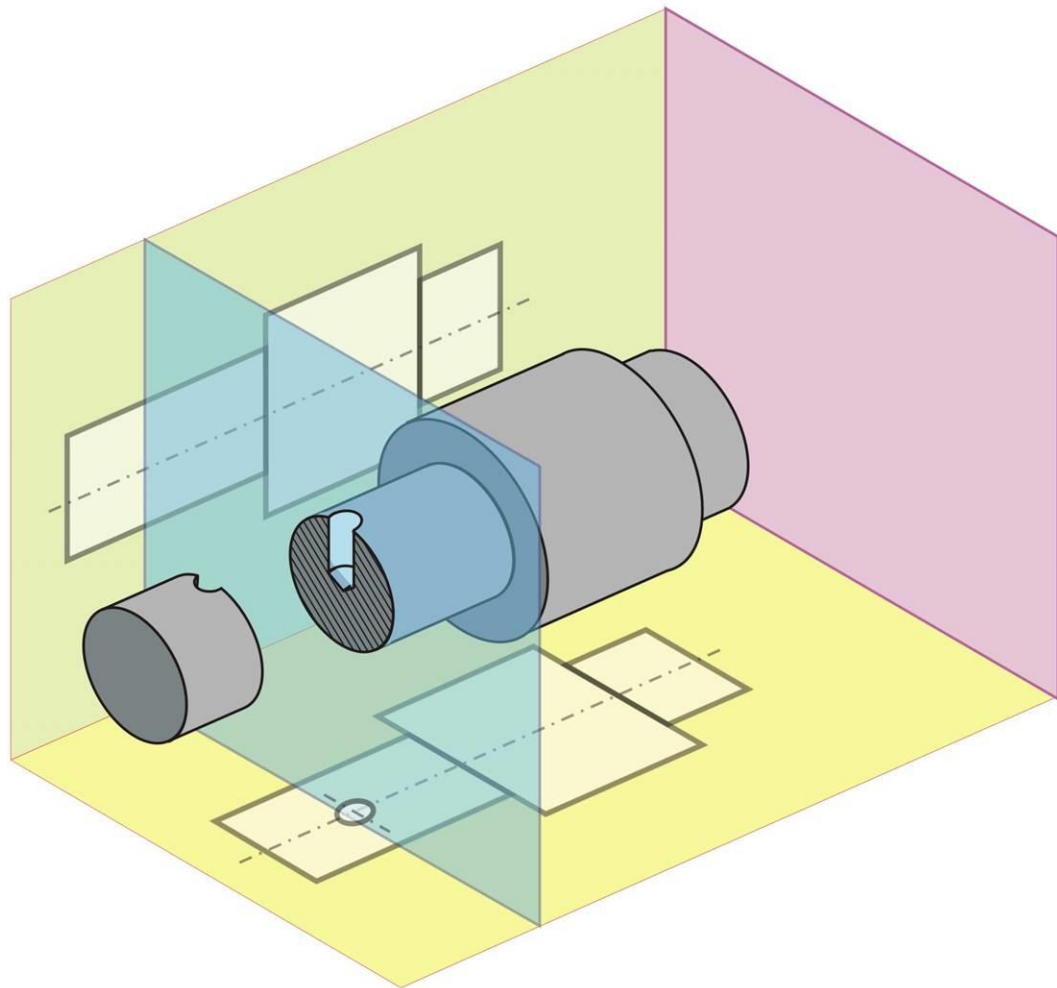

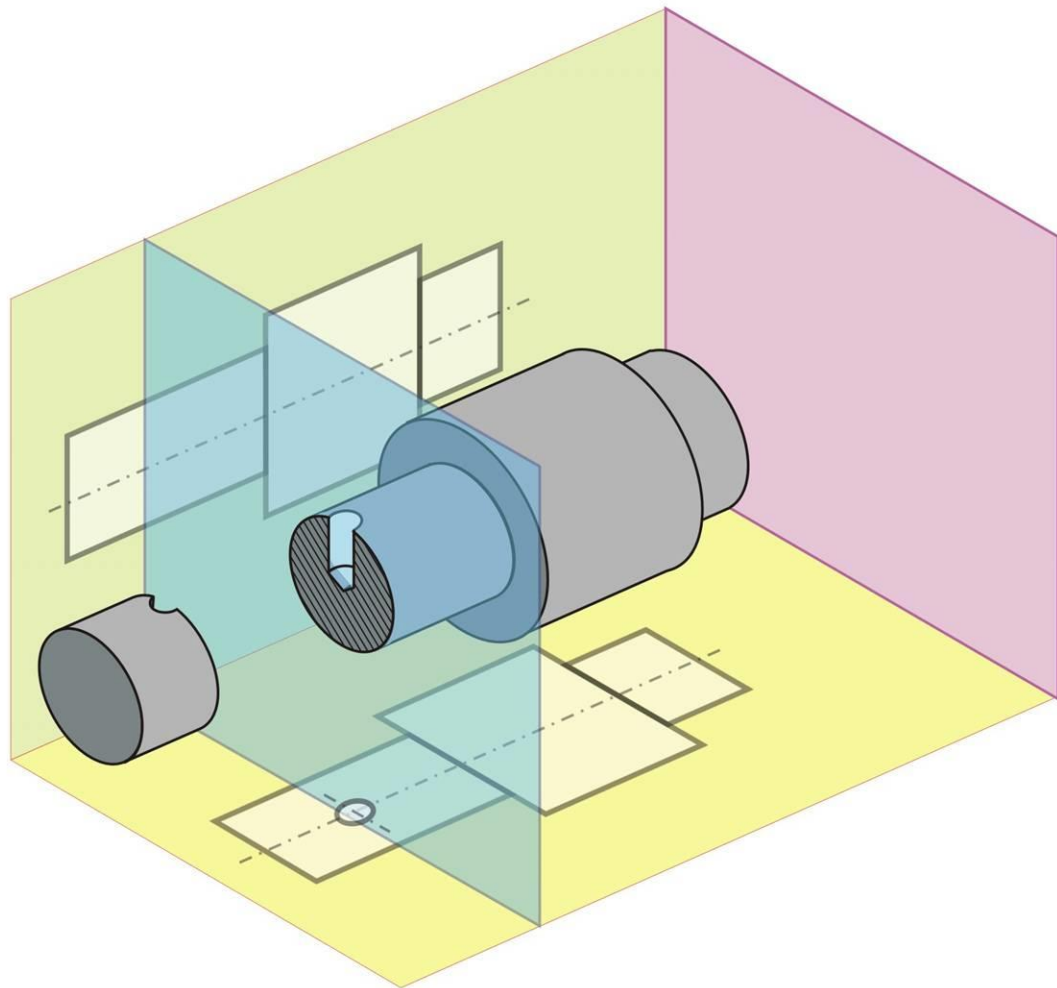

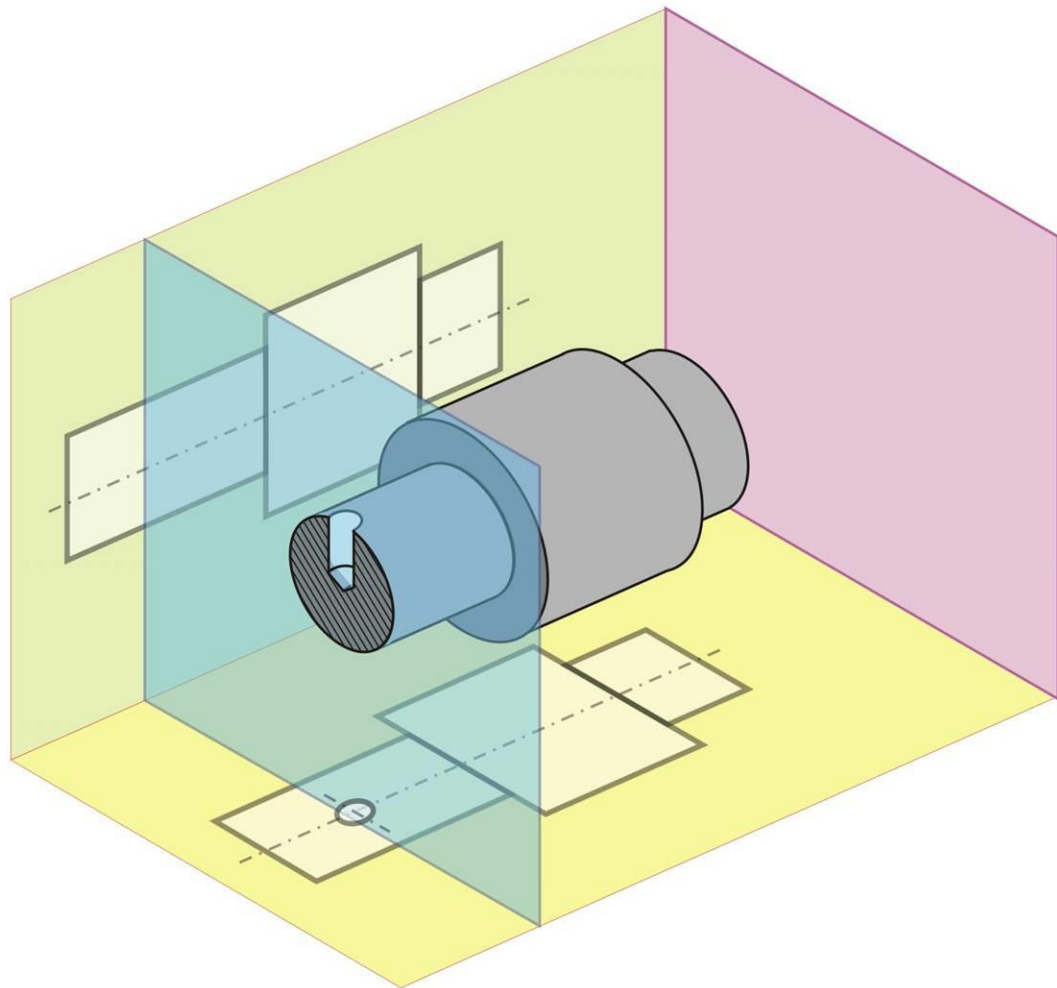

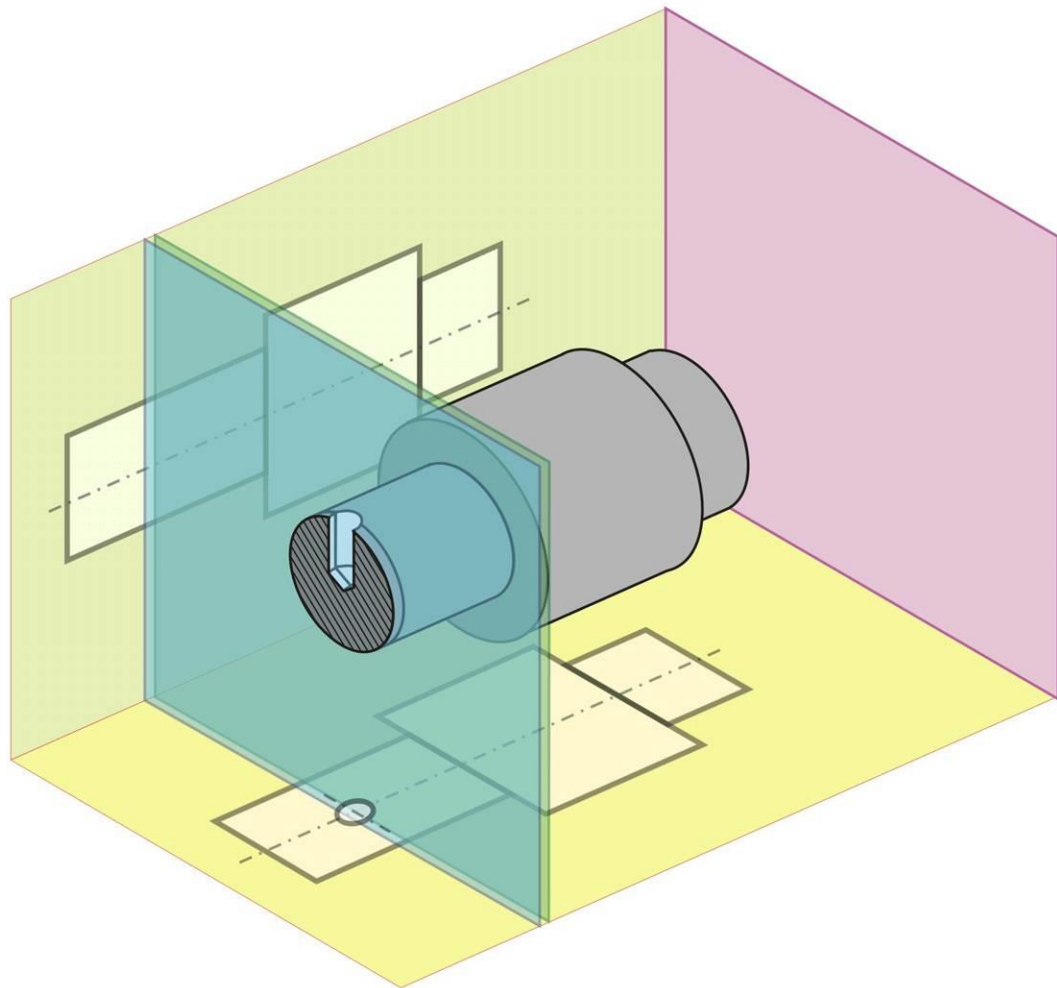



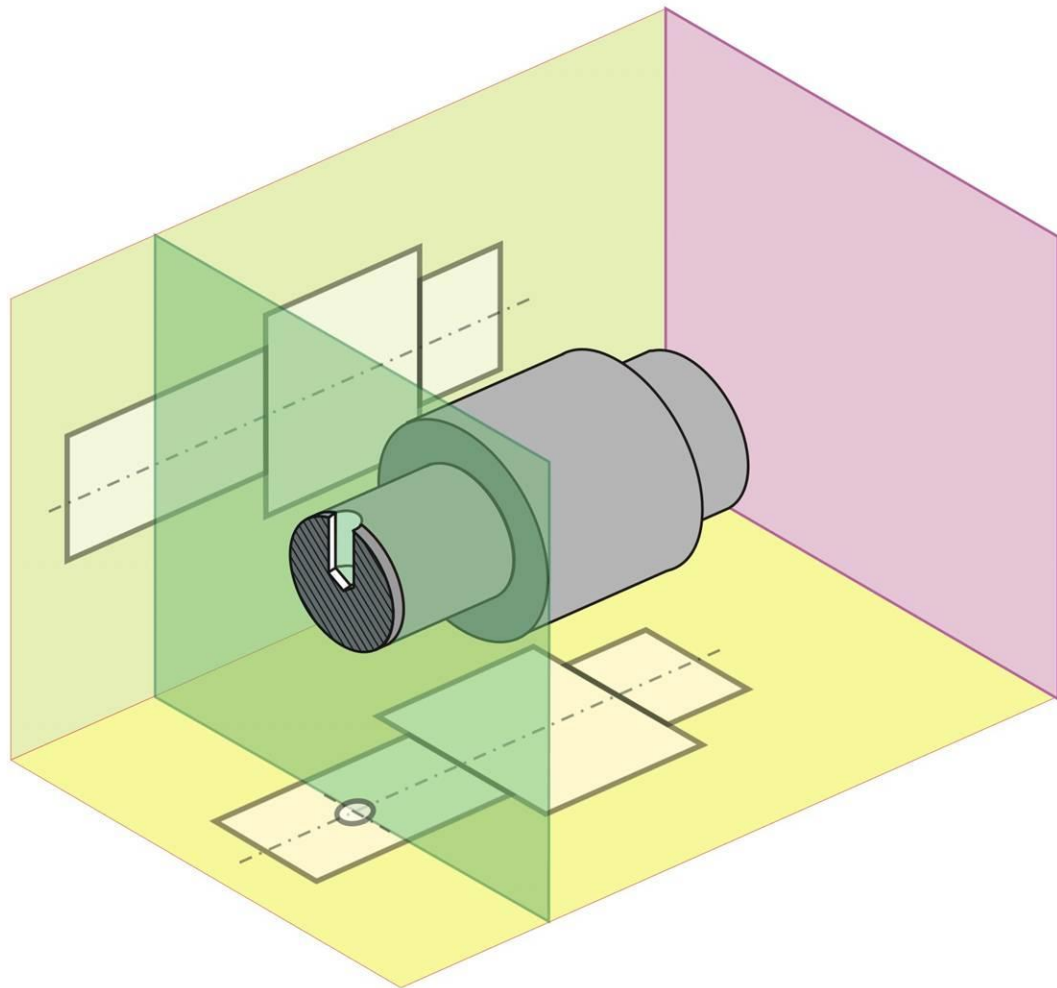

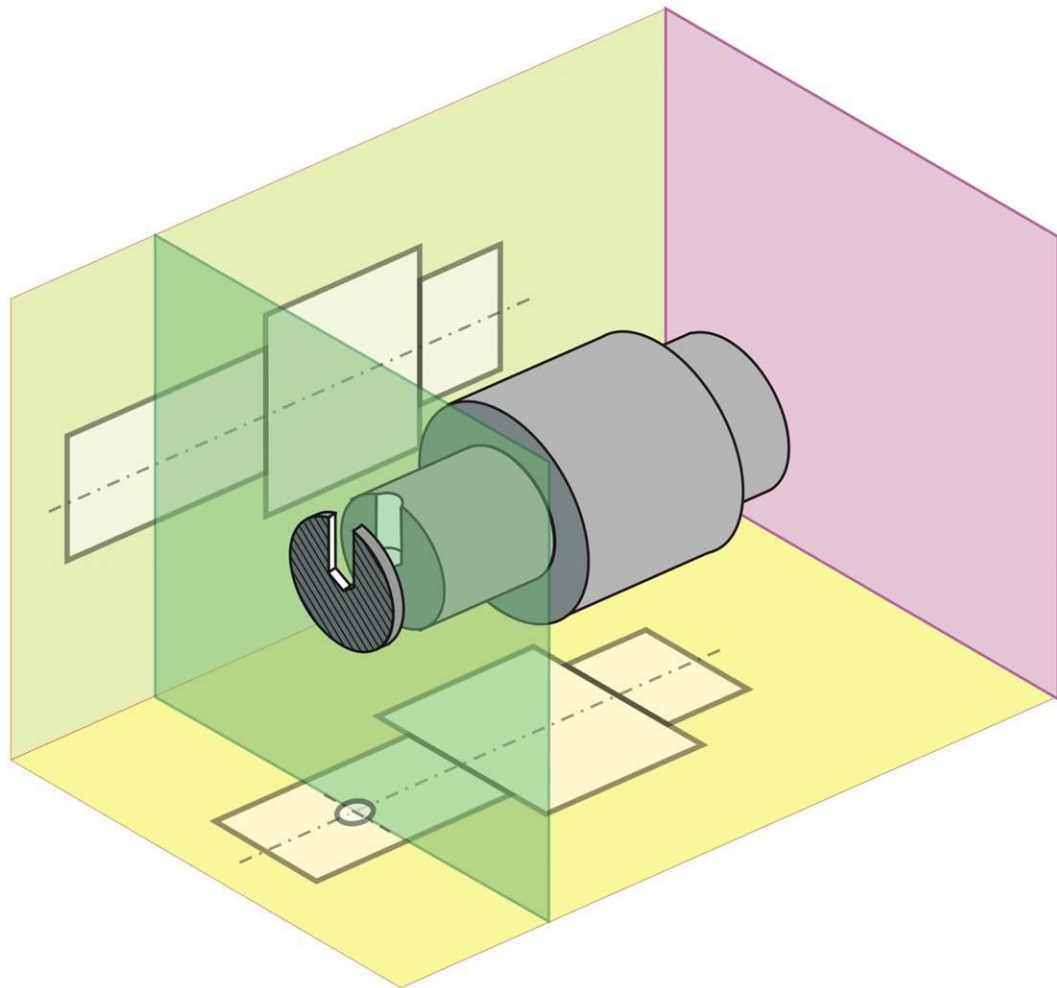

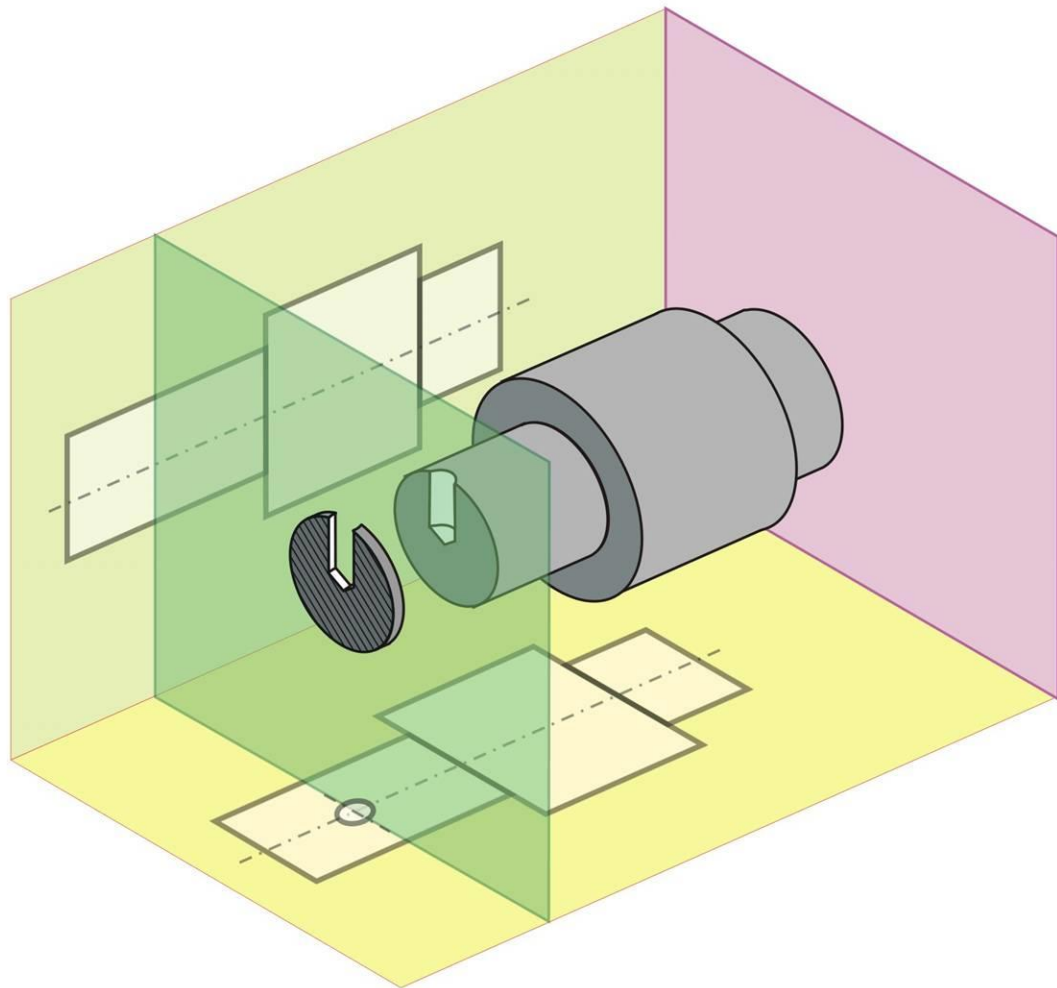

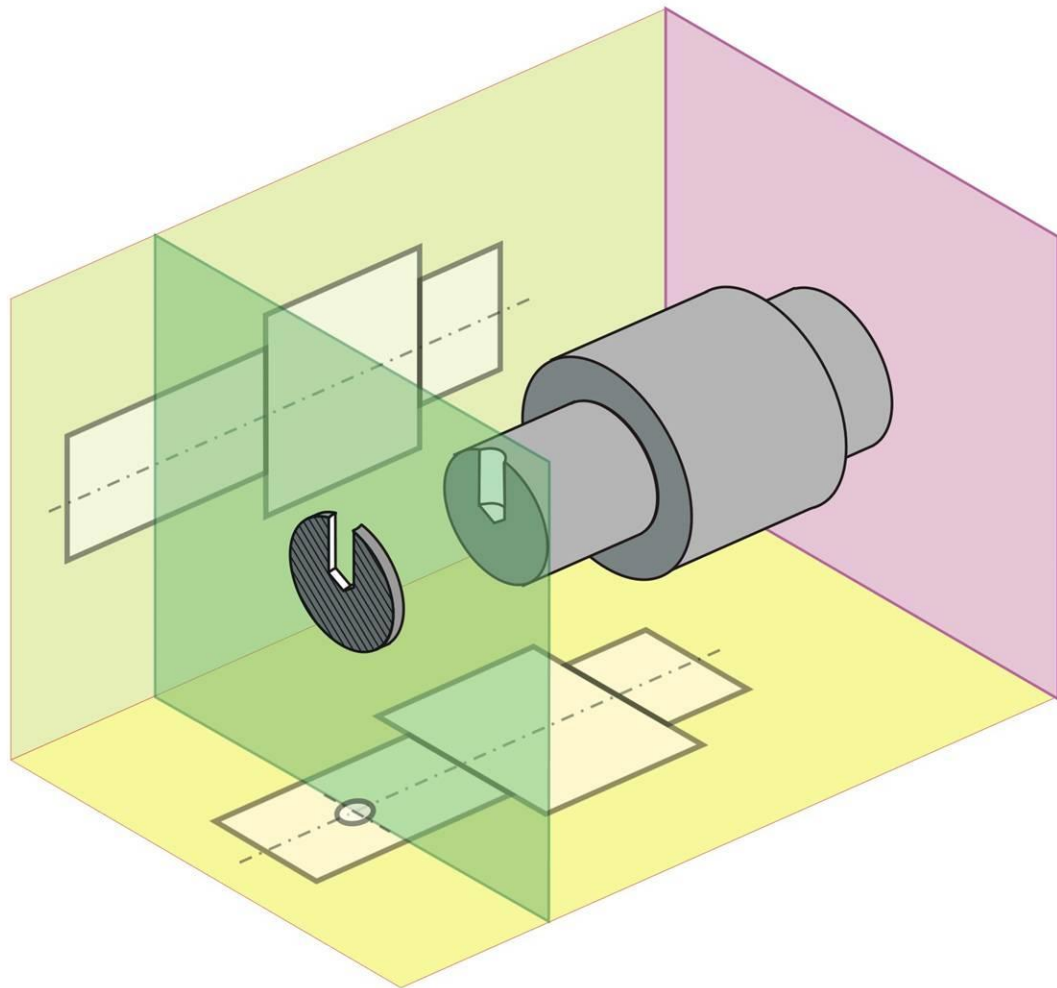

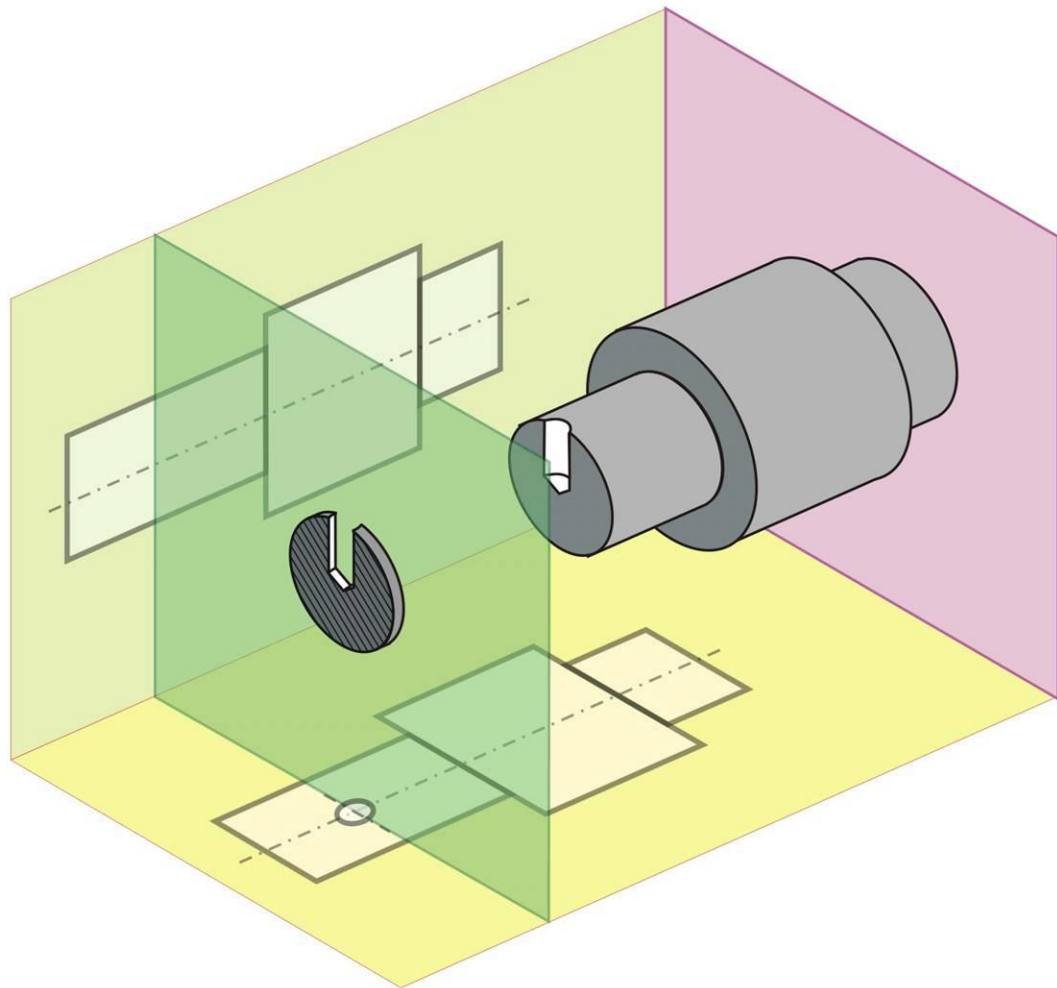

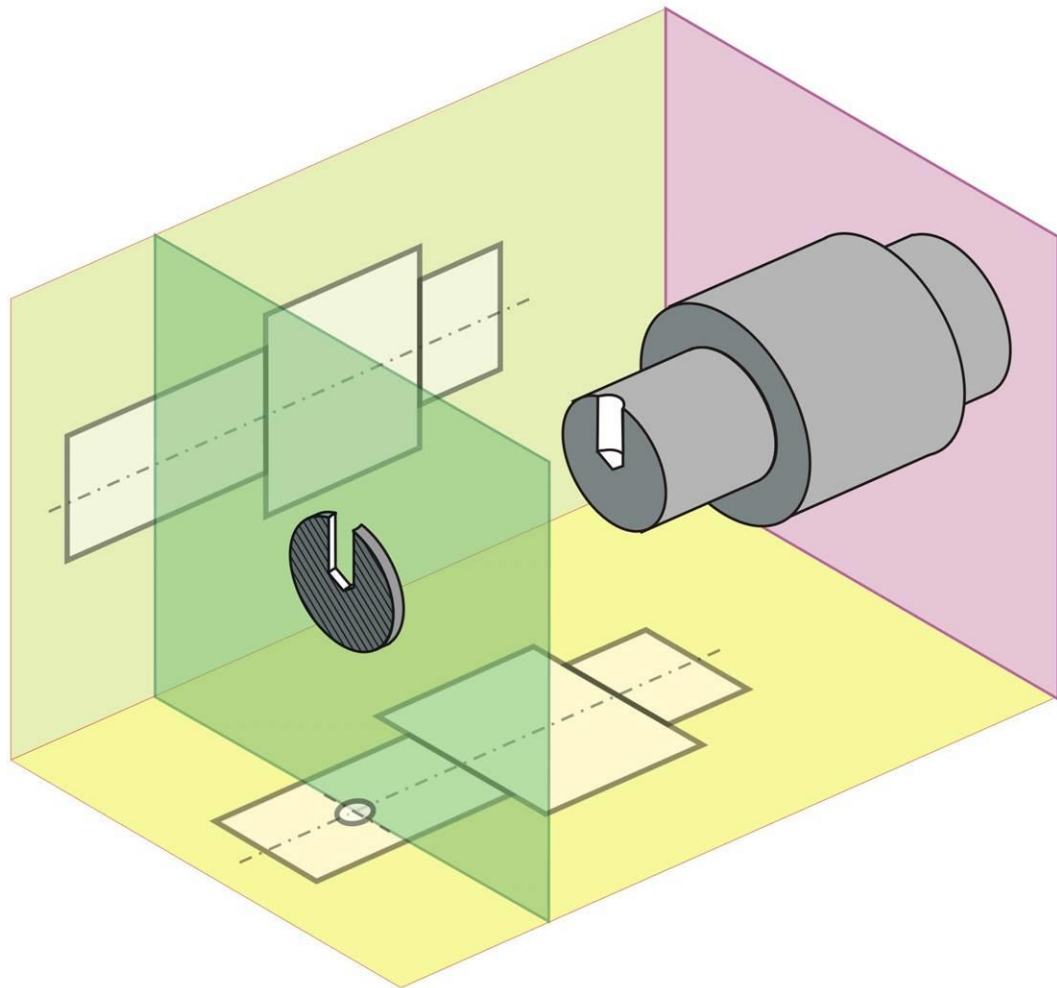

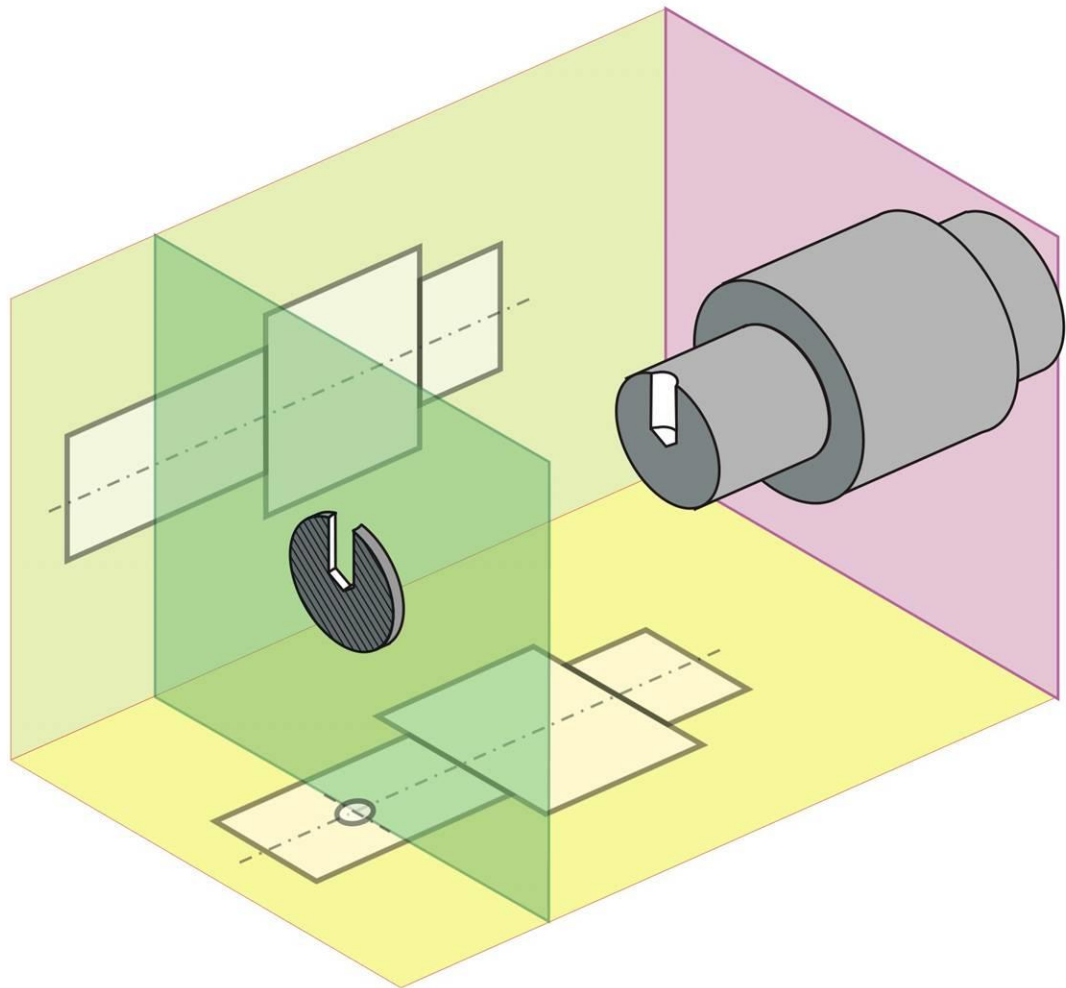

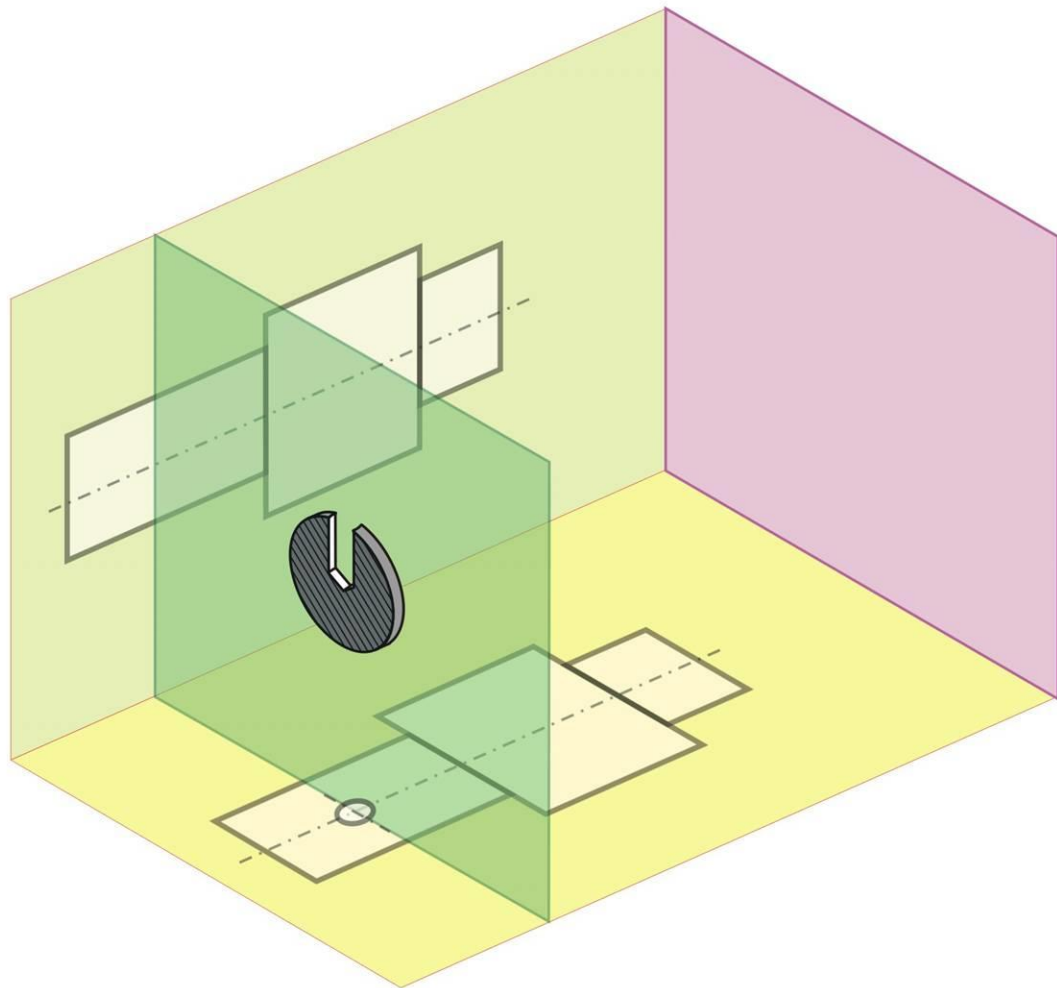



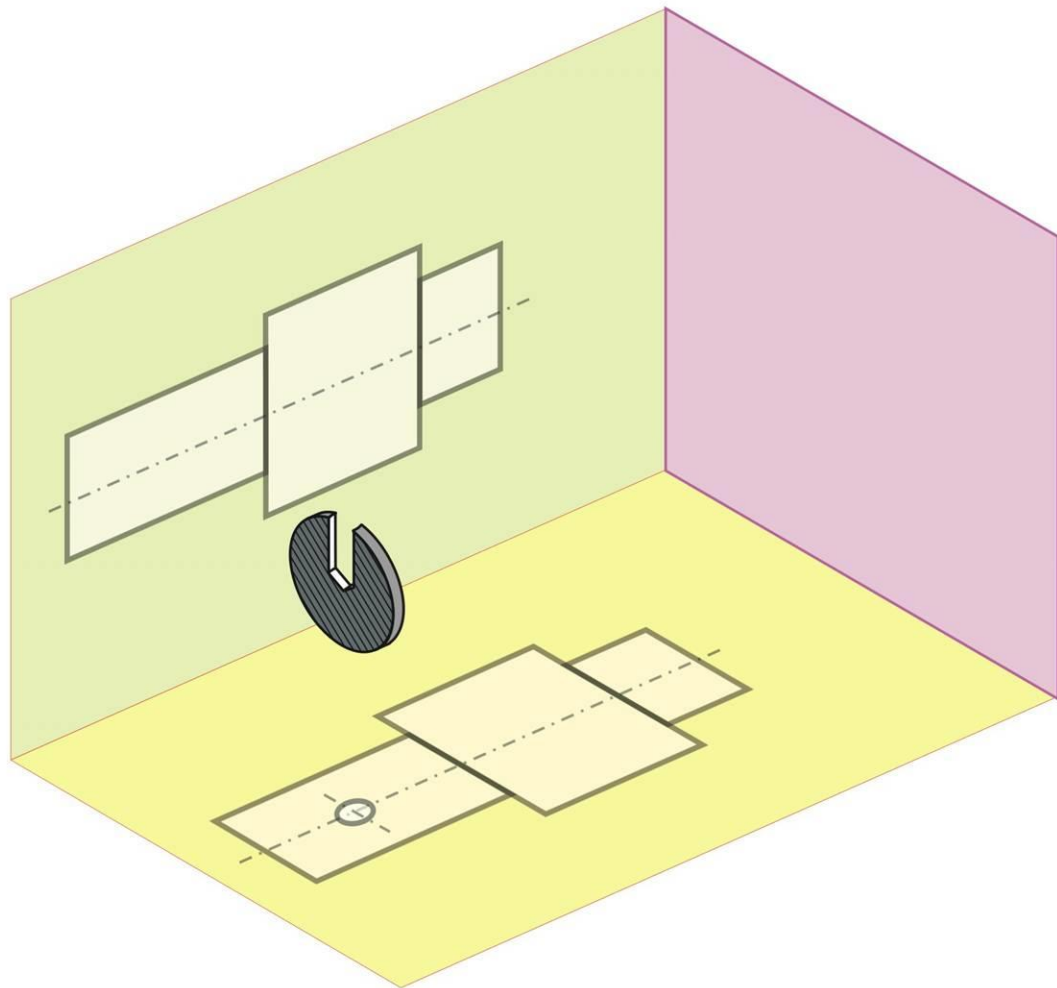

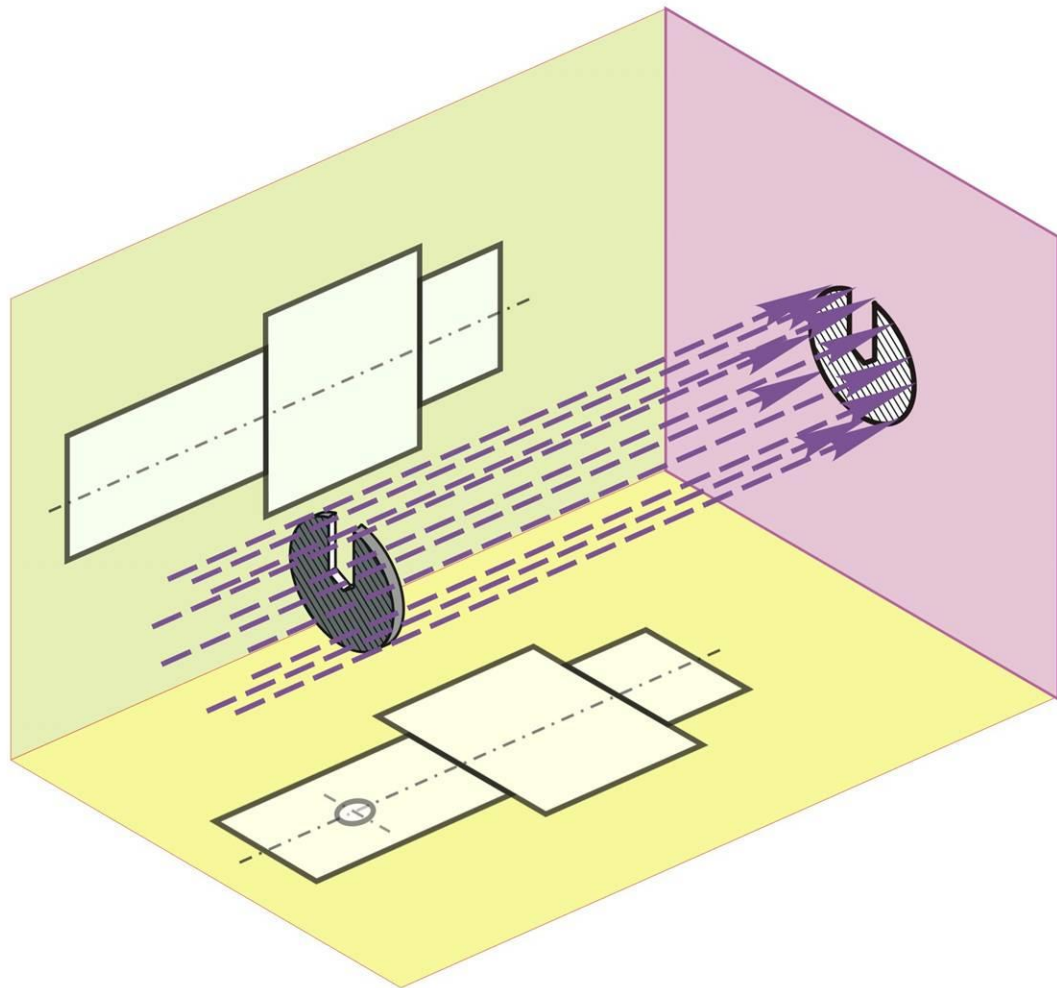

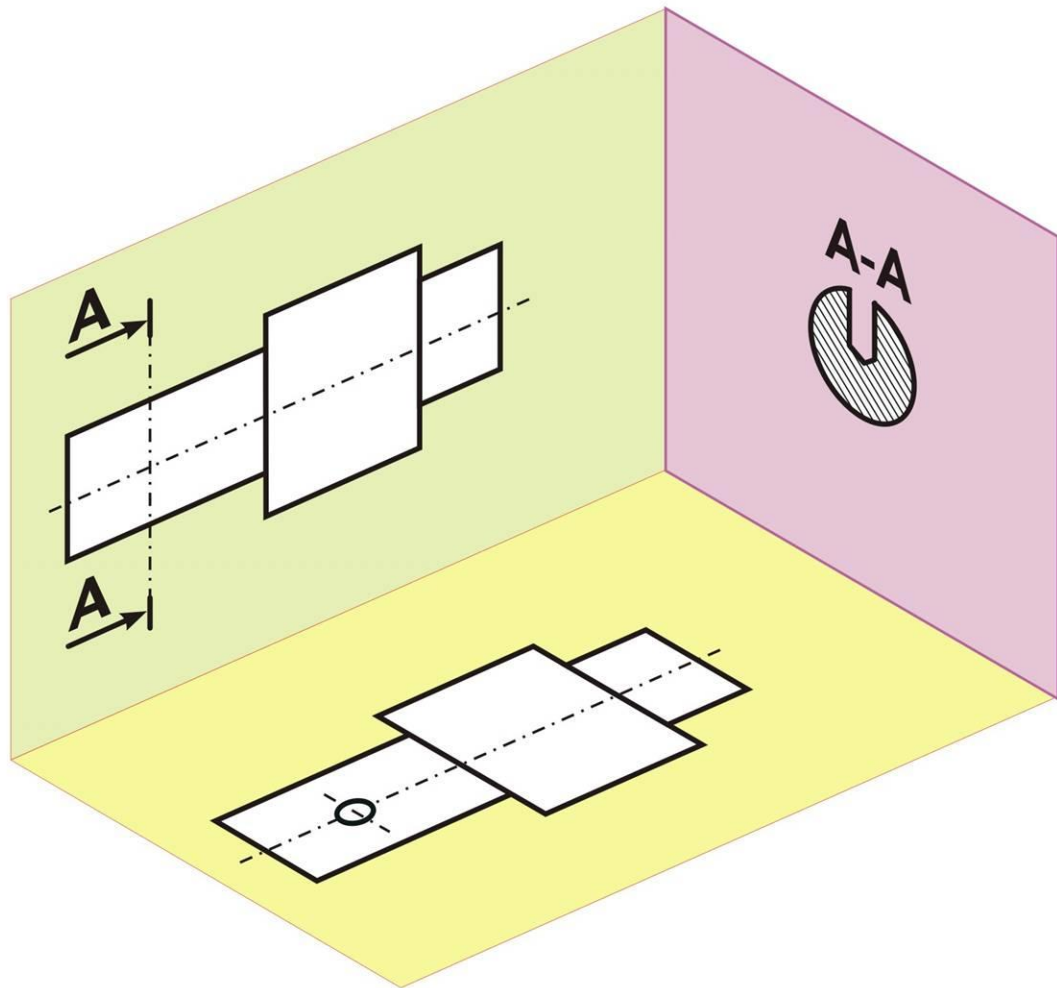

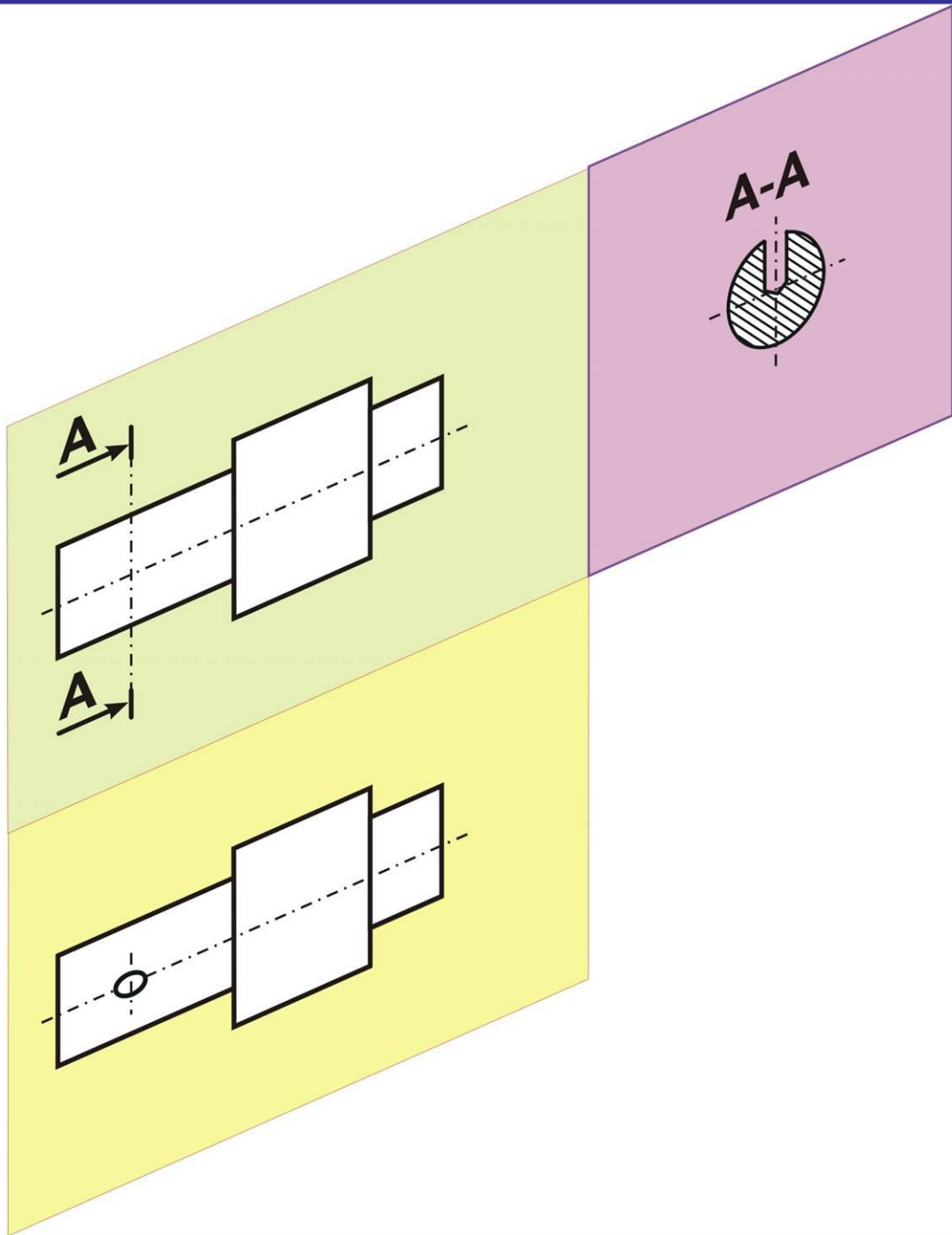

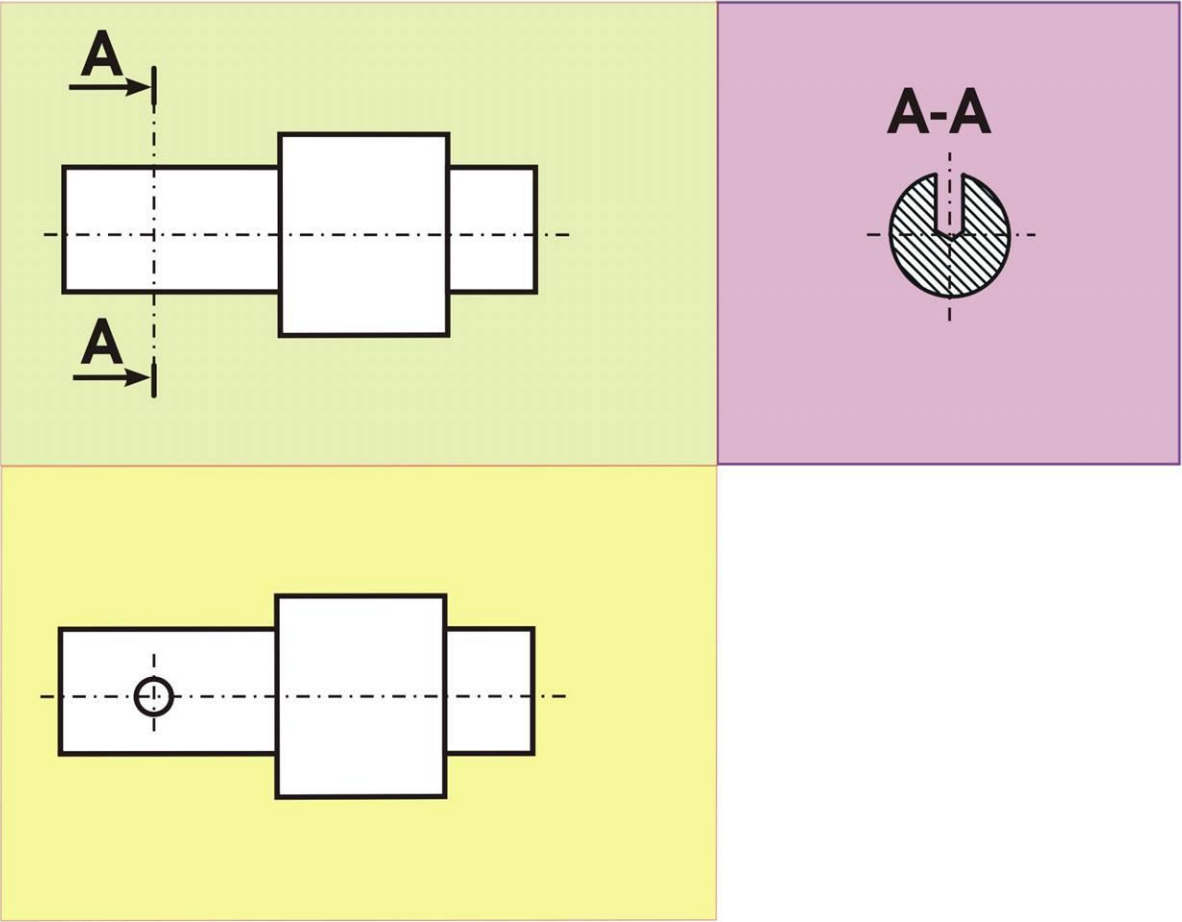

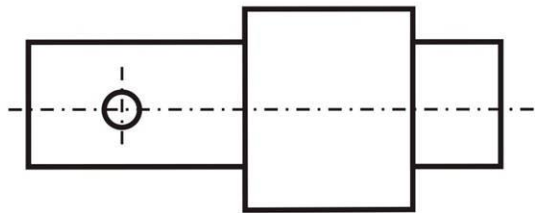
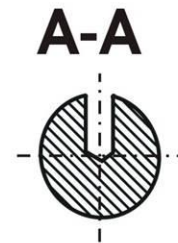
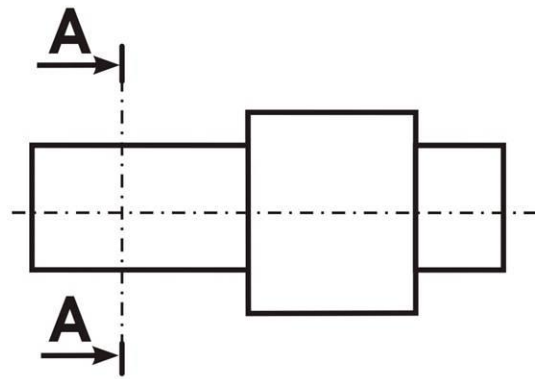

# „Széteső” szelvények ábrázolása

Ábrázolási előírás: A „széteső” szelvényrészeket össze kell kötni

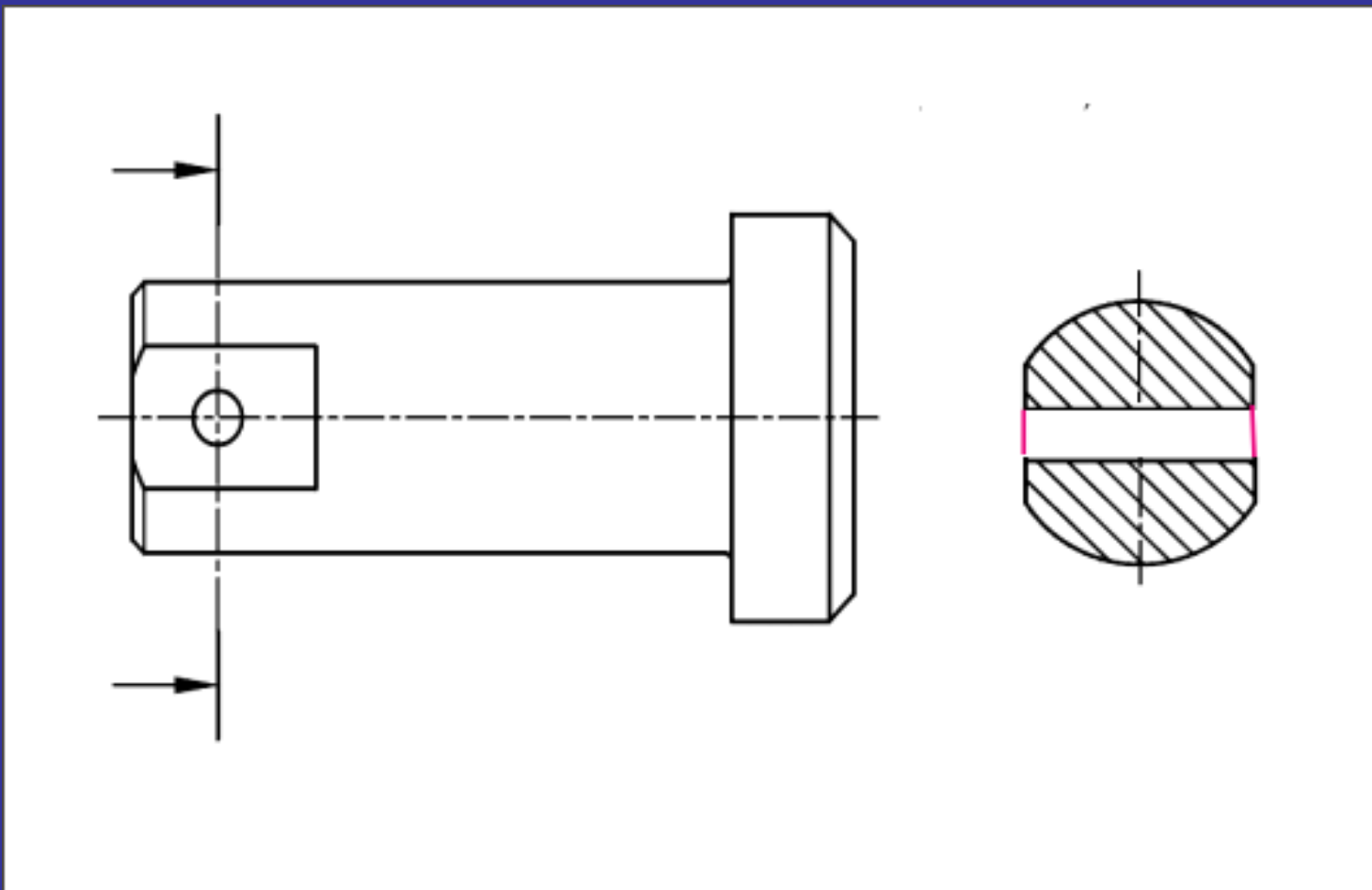

# A SZELVÉNYEK ELHELYEZÉSI MÓDJAI



# Szelvény a nézet közelében, pontvonalal azonosítva

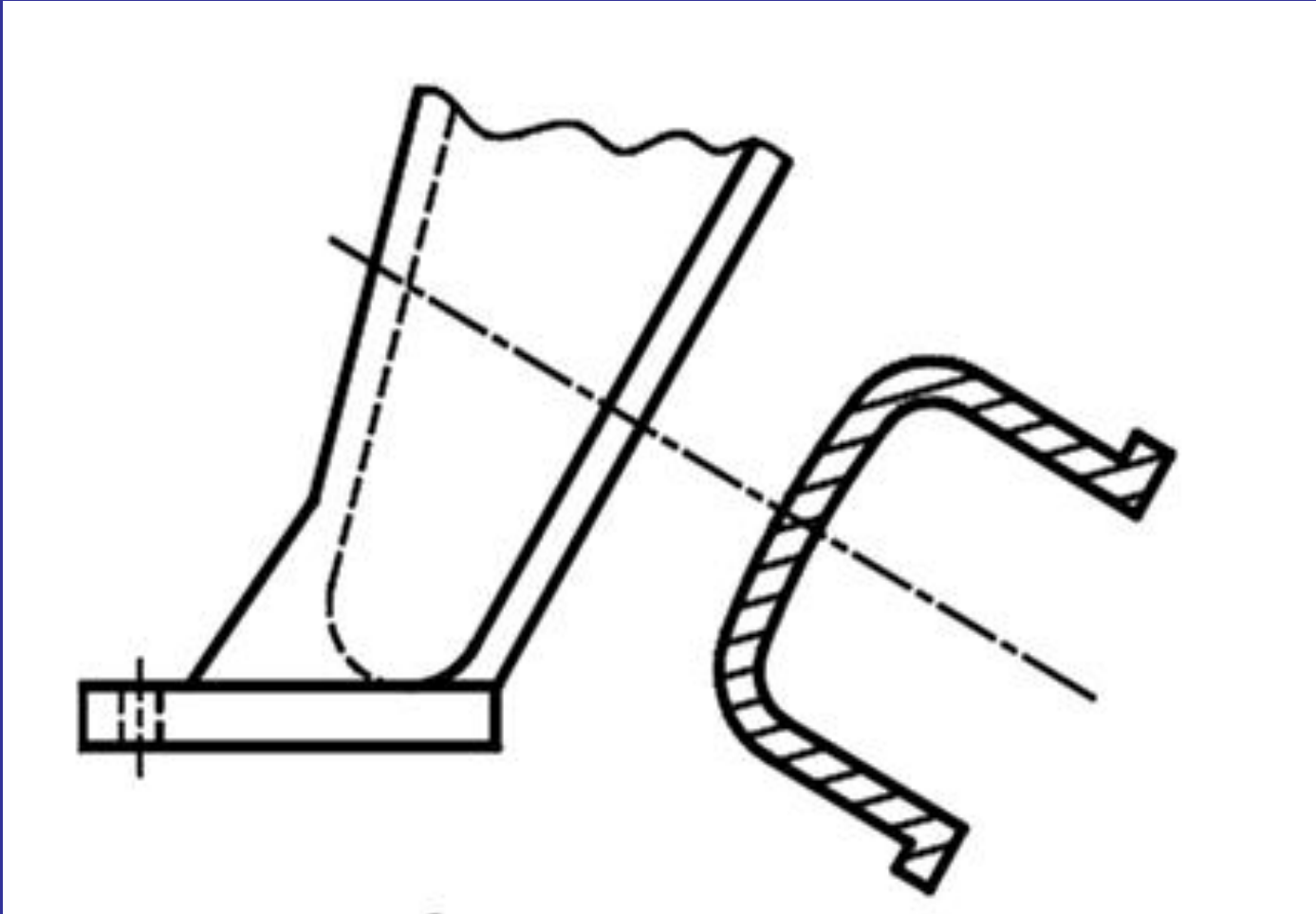

# Szelvény betűkkel azonosítva

(lehet elforgatva is)

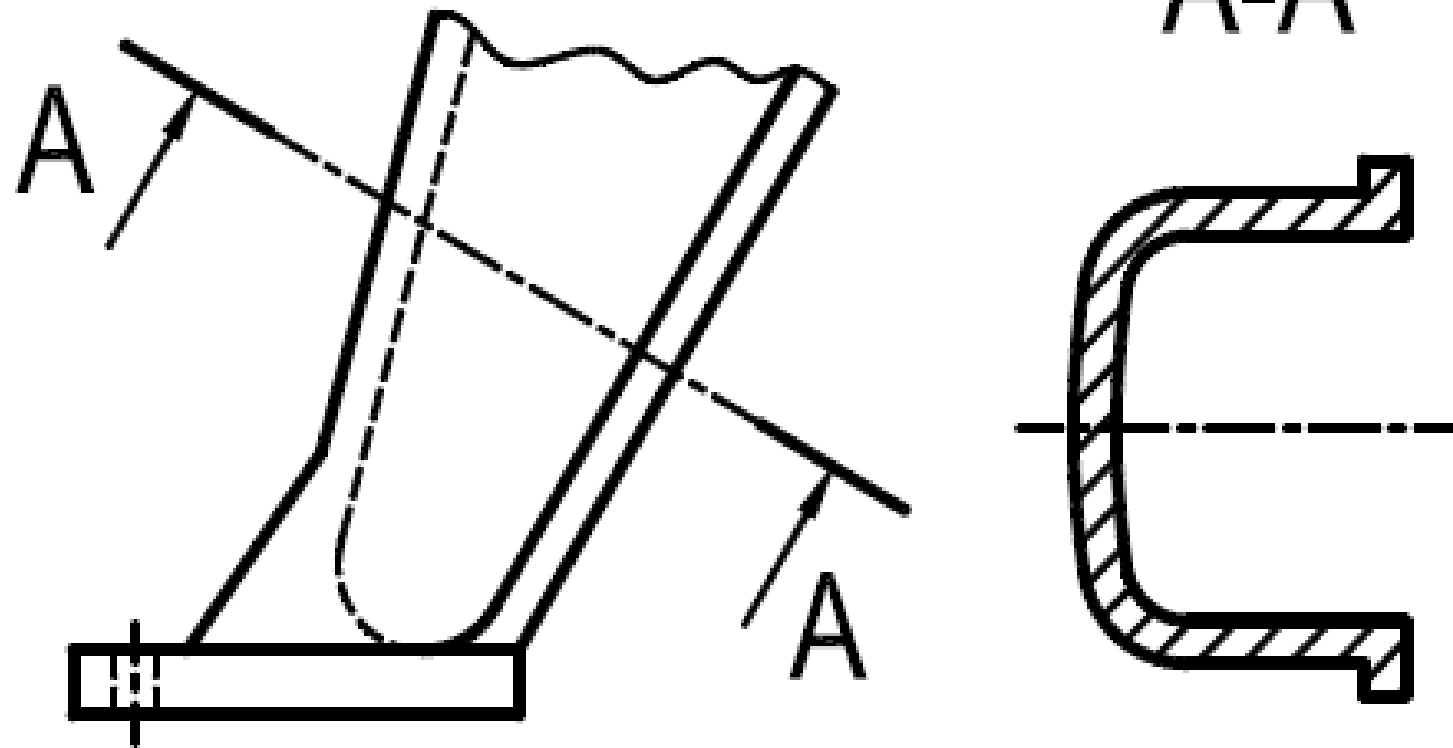

# Beforgatott szelvény

Vékony folytonos vonallal kontúrozva, vonalkázva  
(Azonosításra nincs szükség)

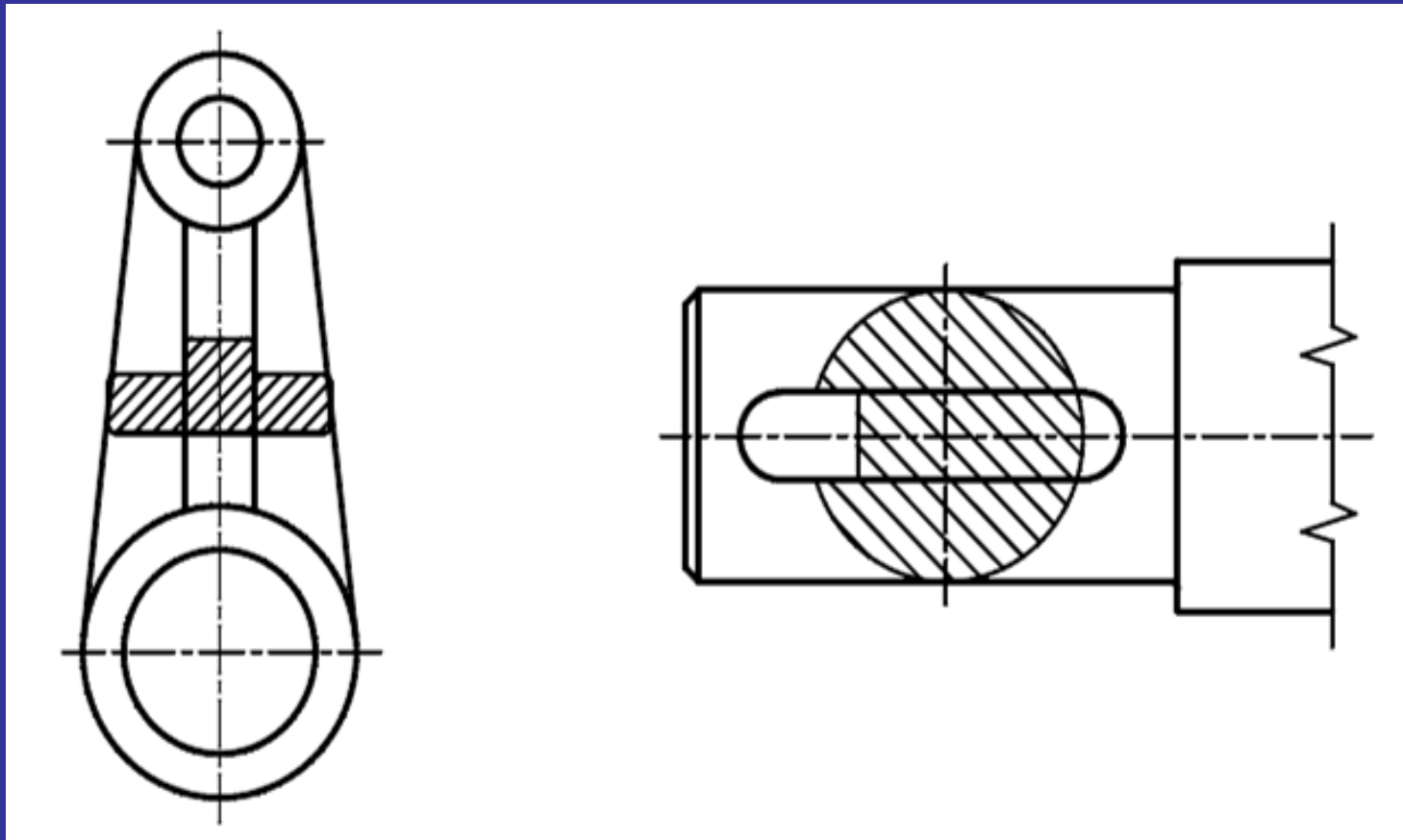

# Szelvénytípusok I.

Azonosítani kell, ha a szelvény helyzete nem egyértelmű

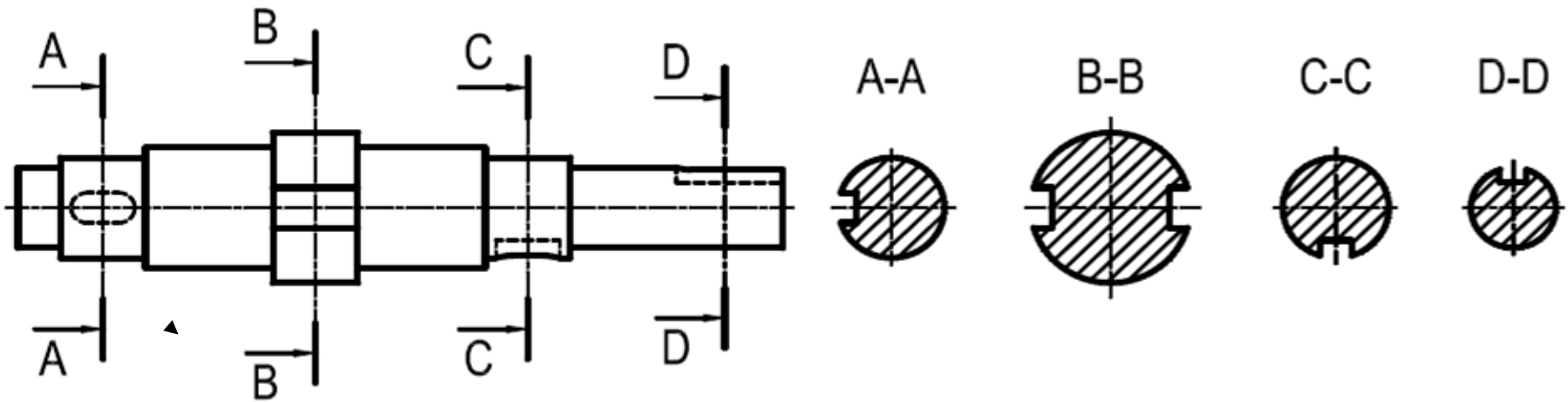

# Szelvénytípusok II.

Azonosítani kell, ha a szelvény helyzete nem egyértelmű

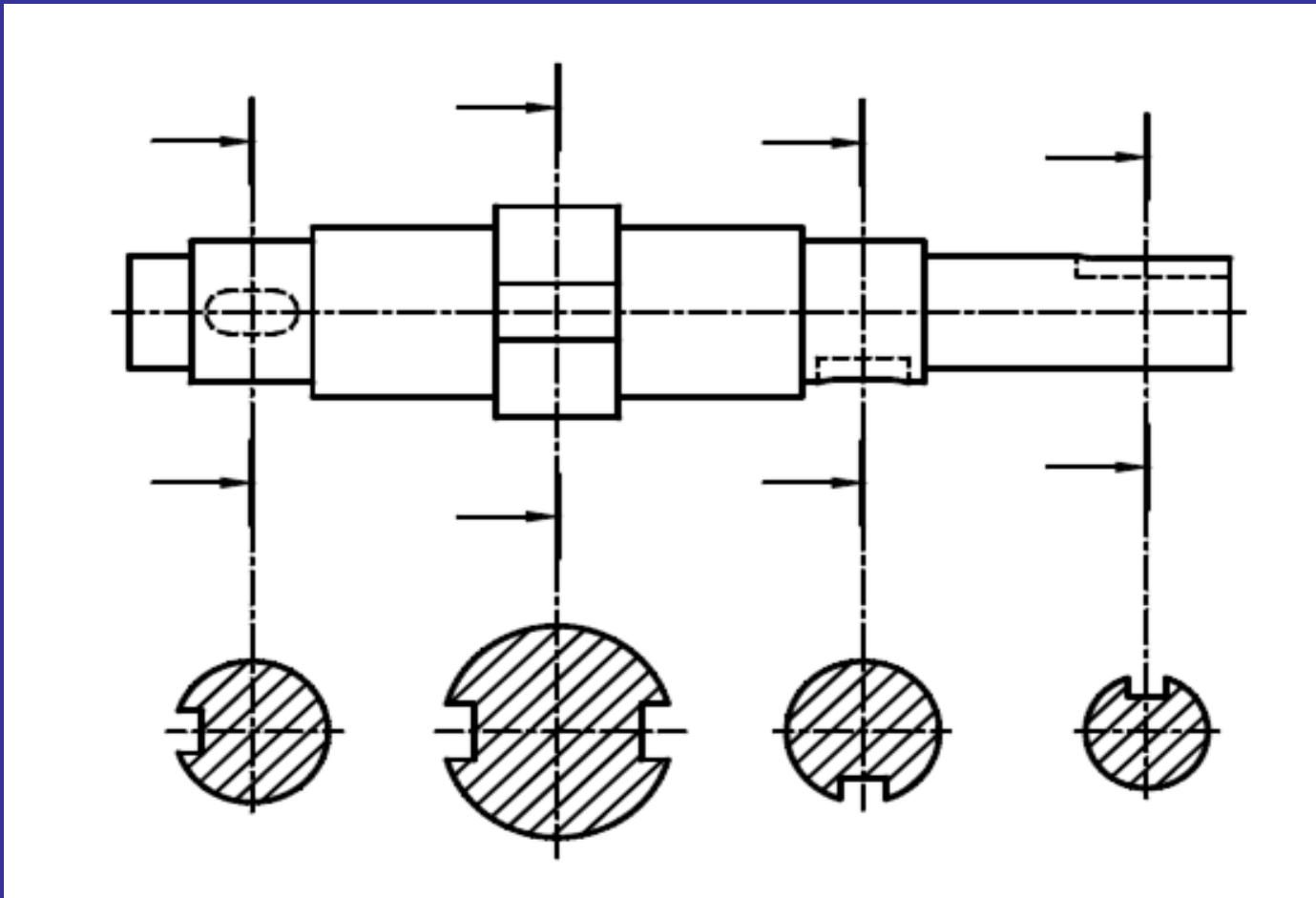

**A MŰSZAKI RAJZOKON  
ALKALMAZANDÓ  
VONALVASTAGSÁGOK**

**Vastag vonalak**

# A vonal rajzolata

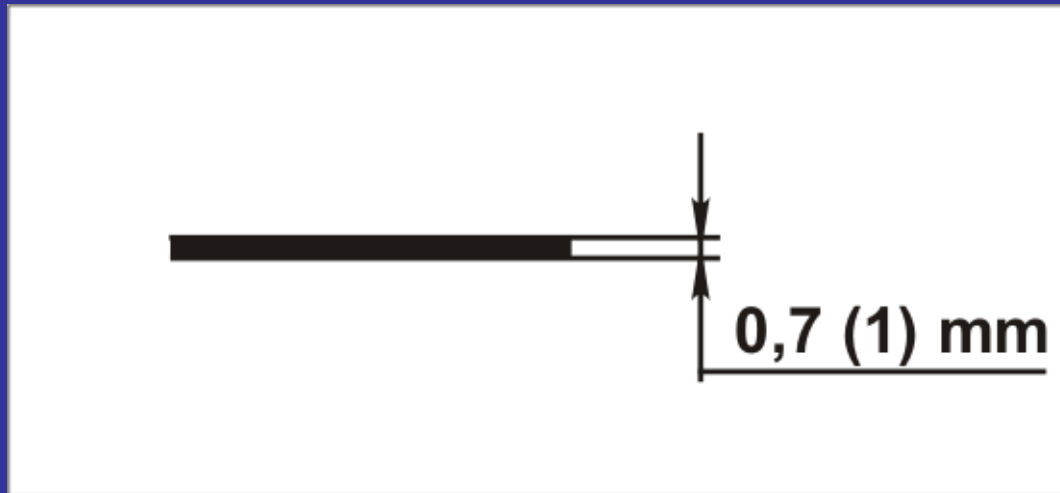



# Kontúrvonalak

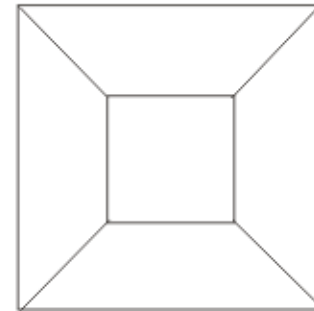
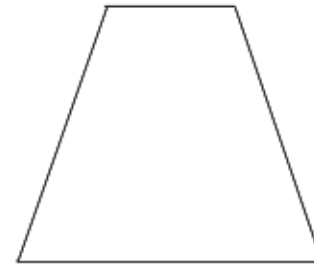
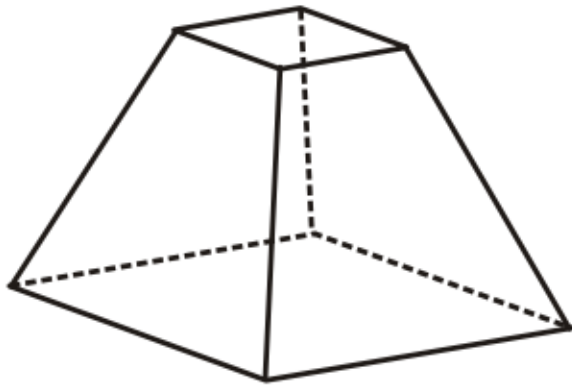

# Kontúrvonalak

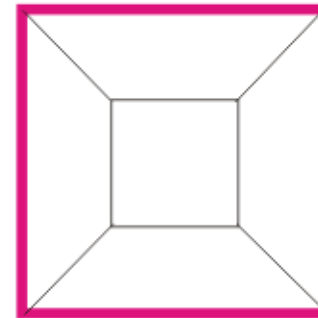
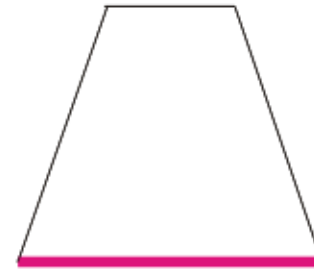
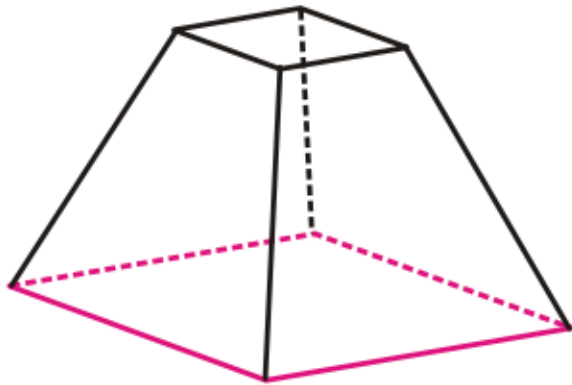

# Felületek határvonalai

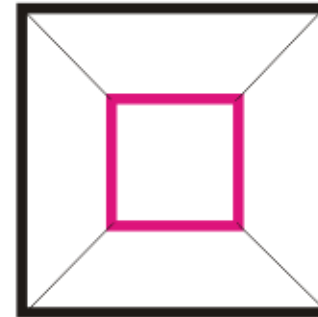
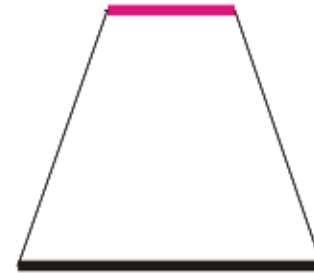
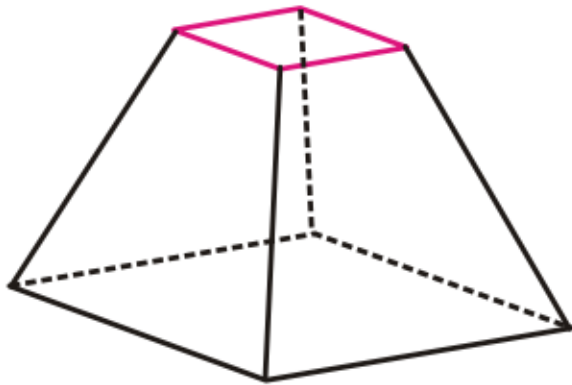

# Az adott nézeten látható élek

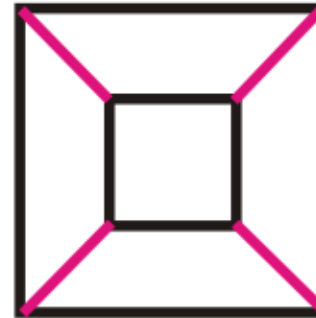
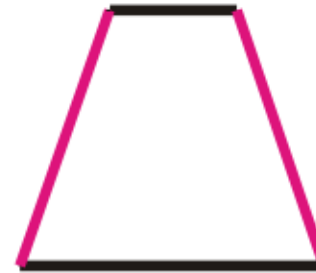
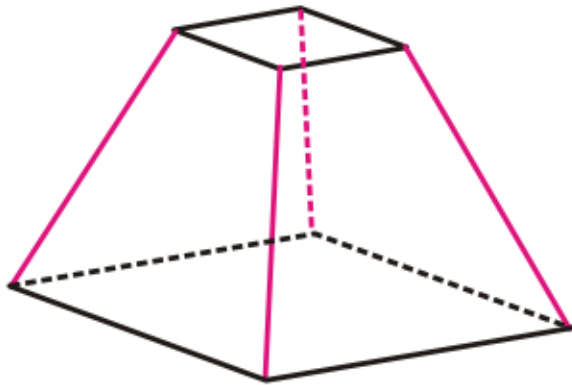

# Az adott nézeten látható élek

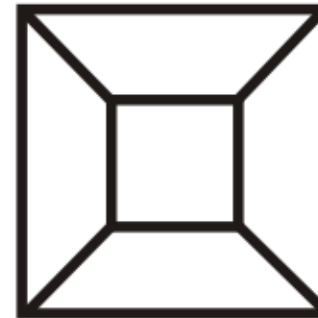
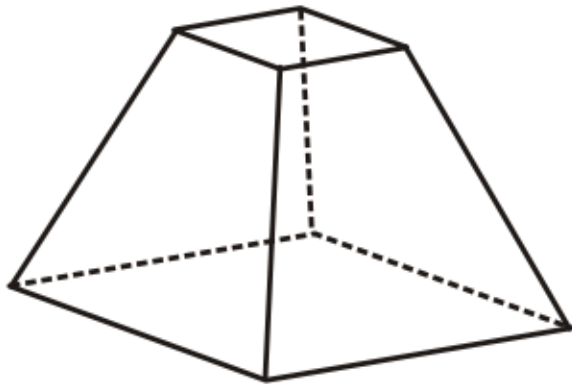

# A nézési iránnyal párhuzamos felületek éle

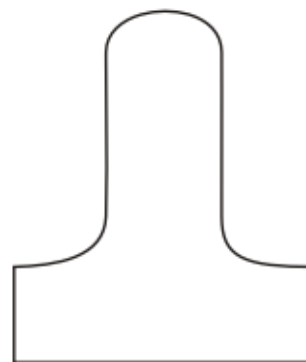
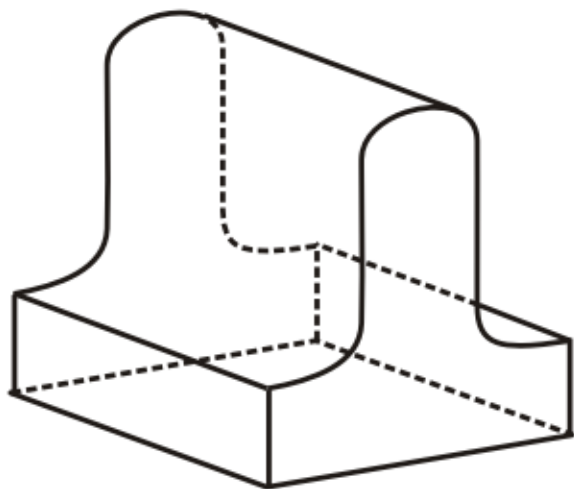

# A nézési iránnyal párhuzamos felületek éle

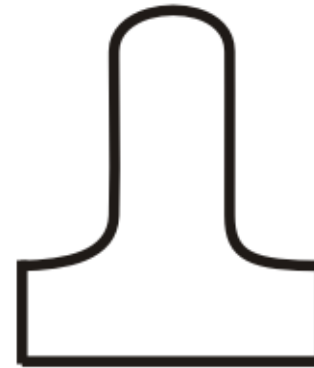
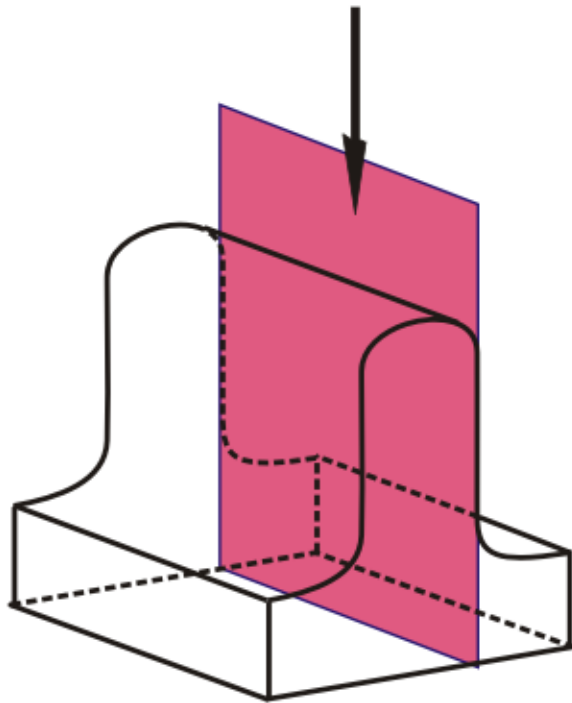

# A nézési iránnyal párhuzamos felületek éle

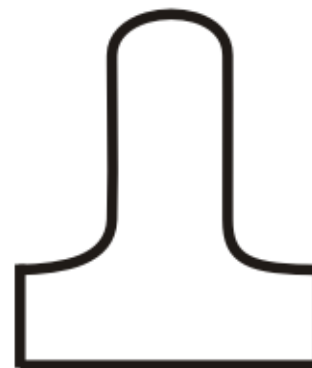
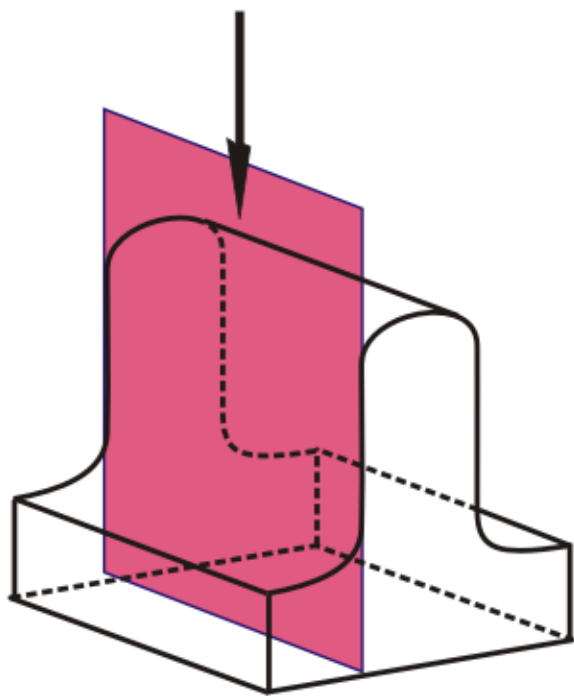



# A nézési iránnyal párhuzamos felületek éle

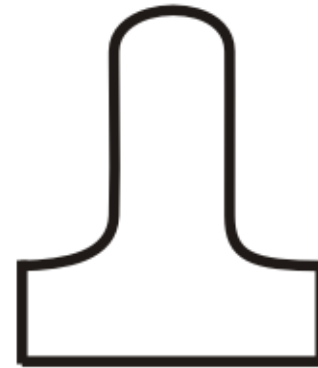
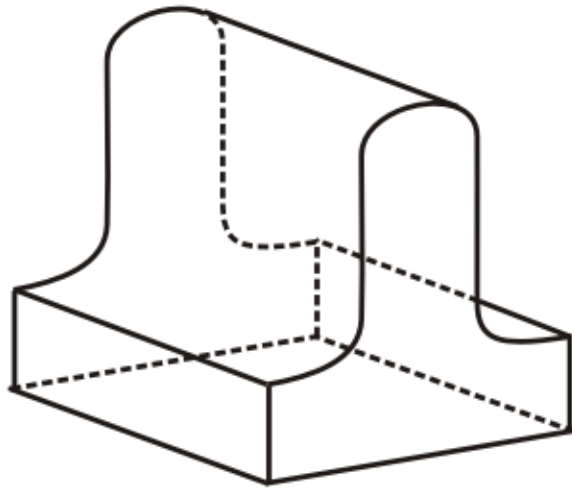

# Éles vonalú (nem legömbölyített) áthatások

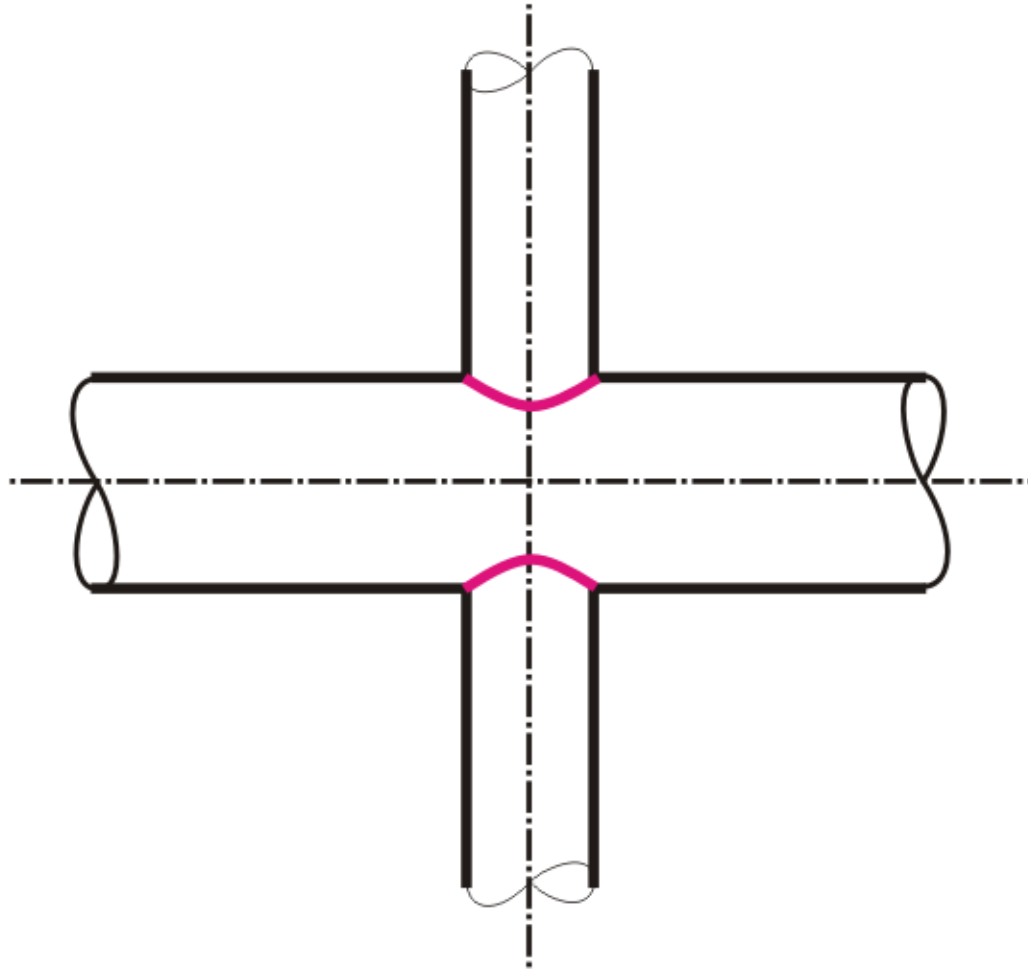

# Ismétlődő elemek külső burkolóvonalala

Menetes orsó

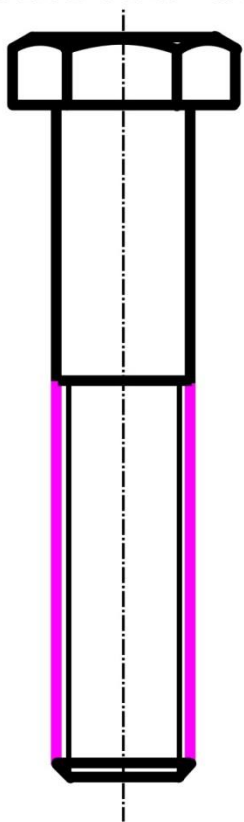

Fogaskerék

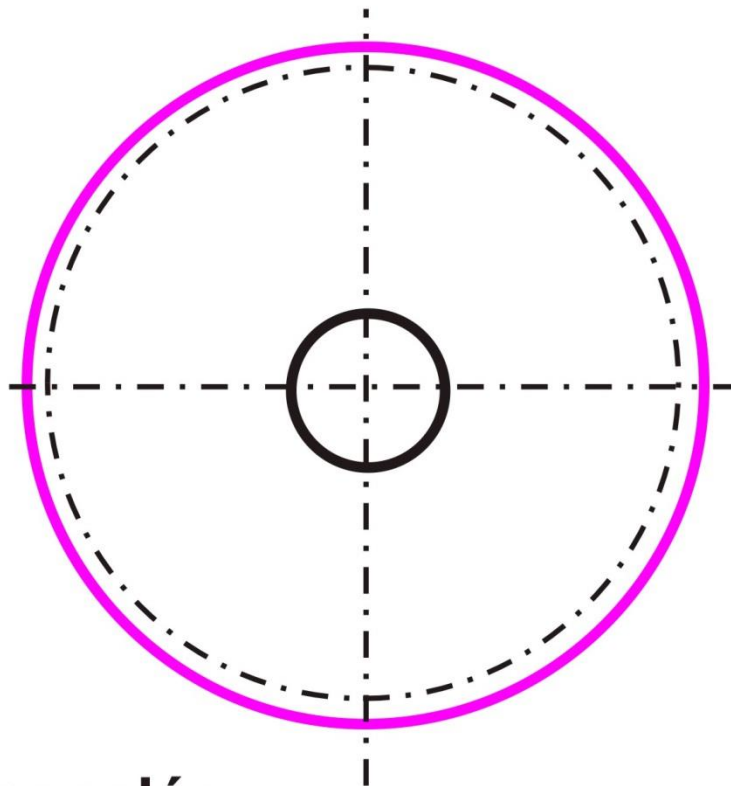

Fogasléc



# Metszetek nyomvonalának végei

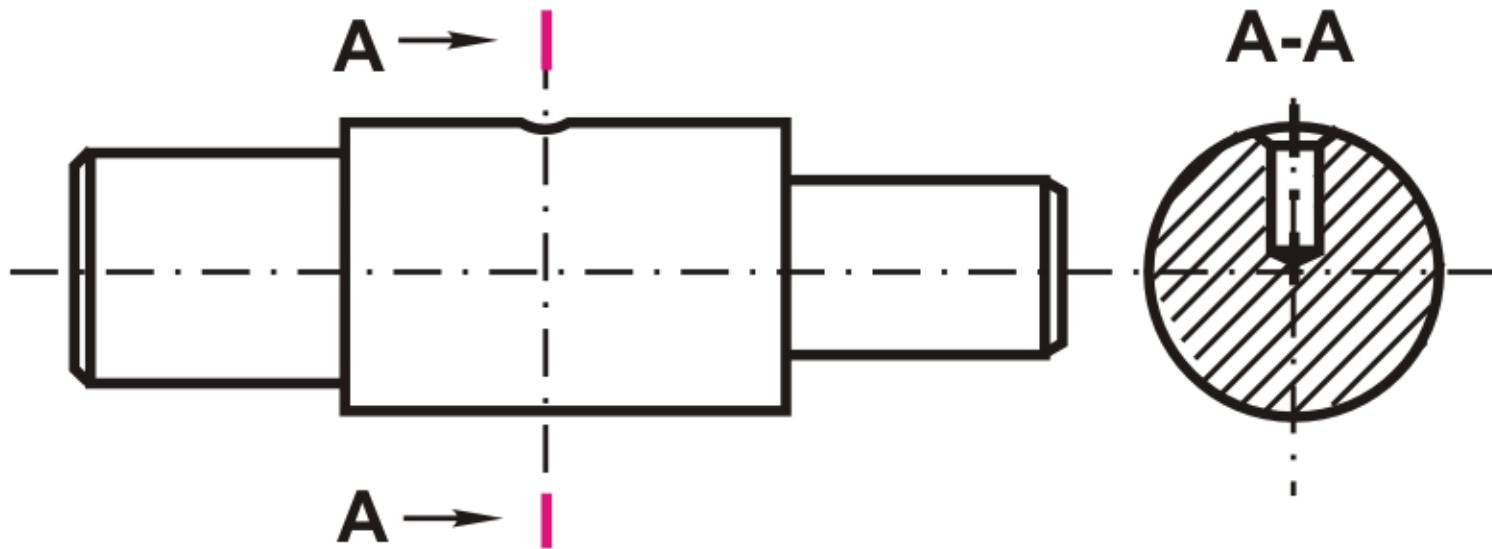

# Vékony vonalak

# A vonal rajzolata

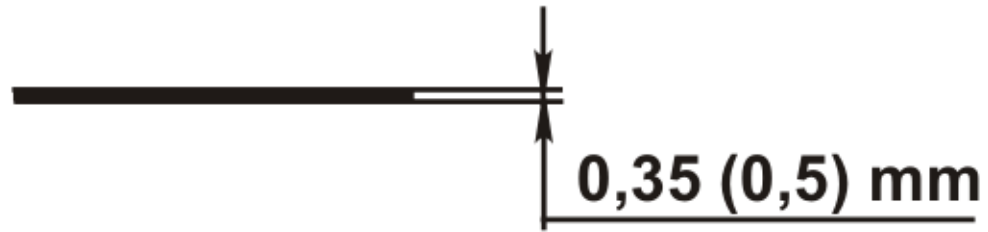

# Tagoló vonalak

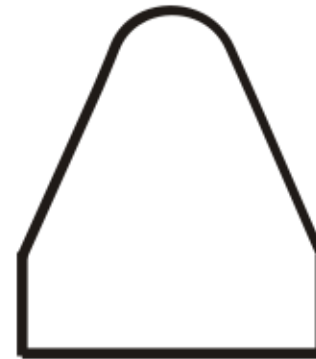
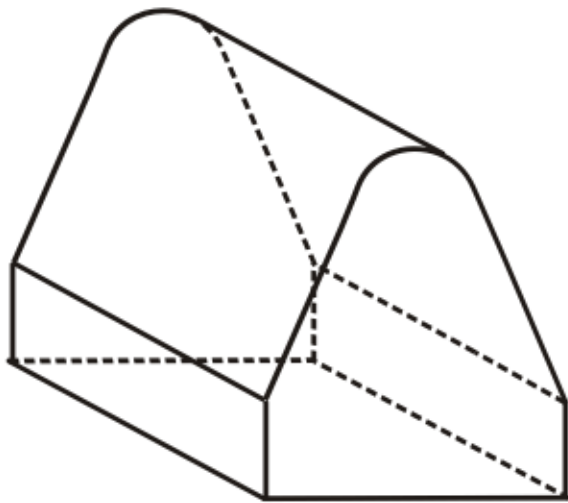

# Tagoló vonalak

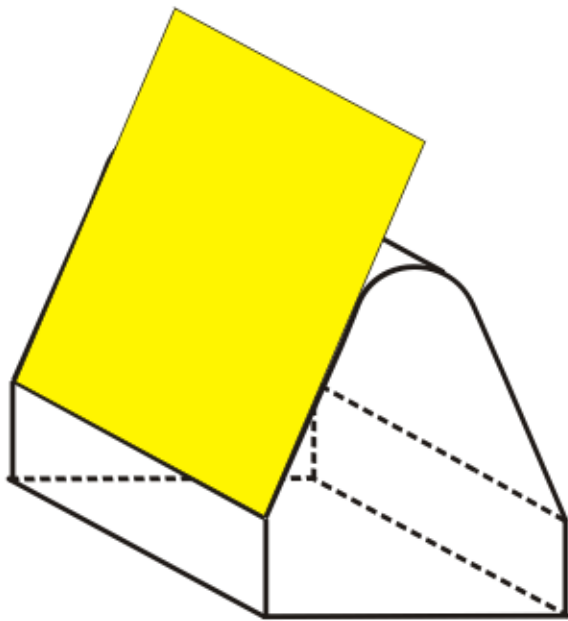



# Tagoló vonalak

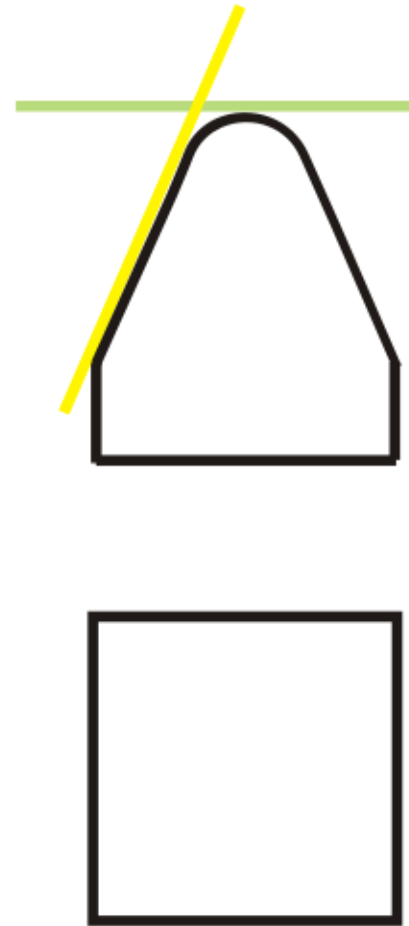
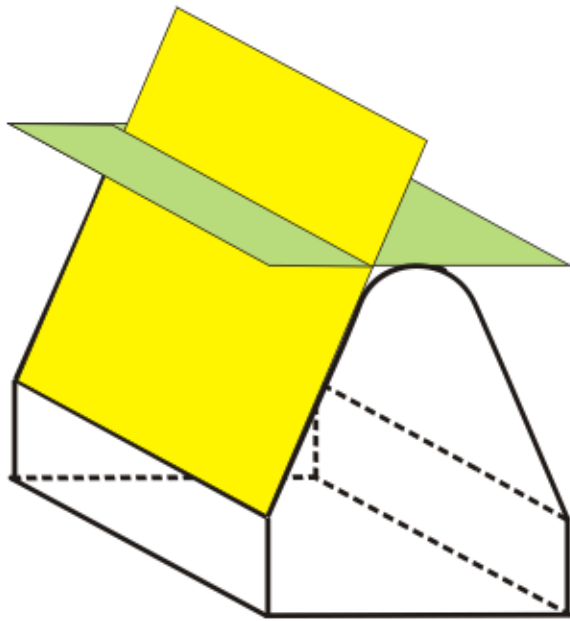

# Tagoló vonalak

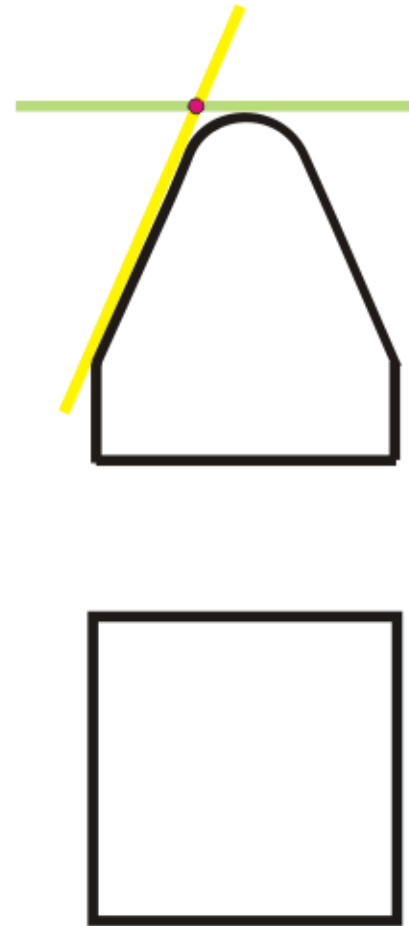
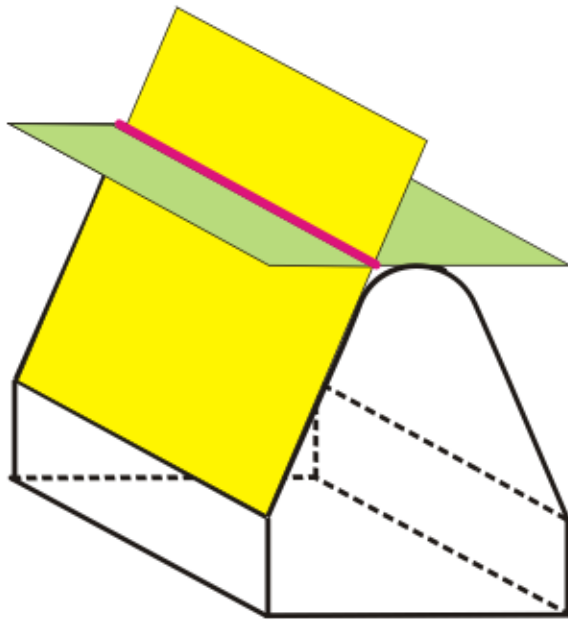

# Tagoló vonalak

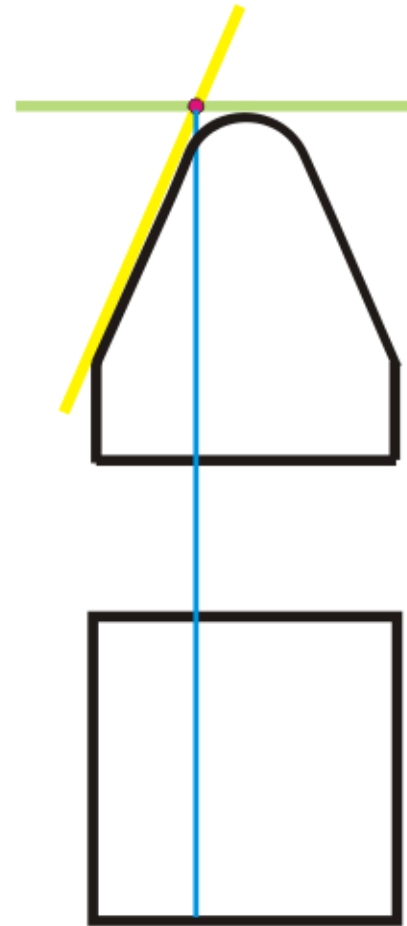
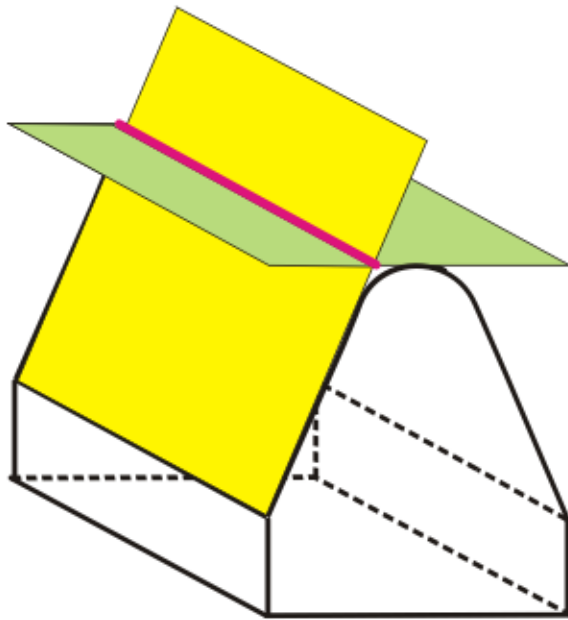

# Tagoló vonalak

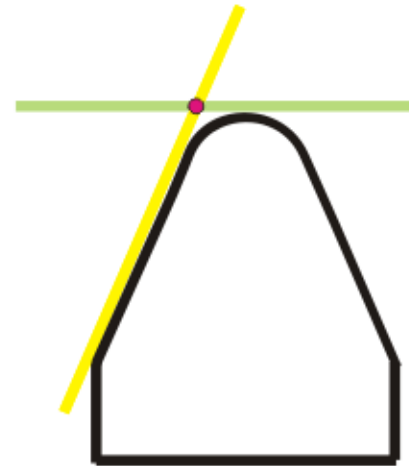
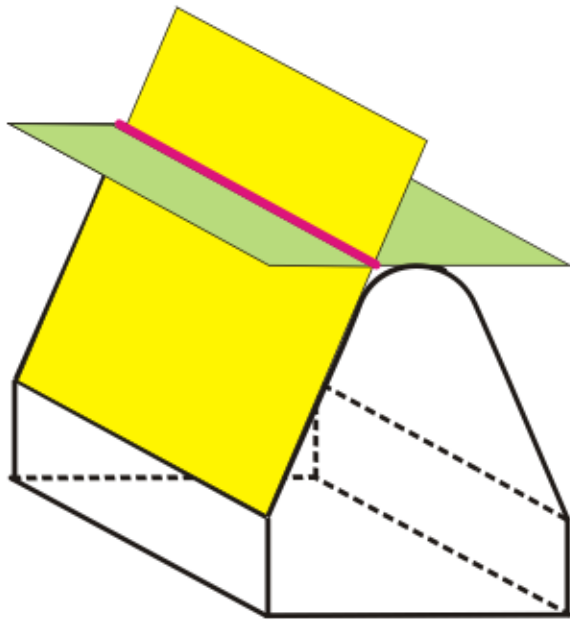

# Tagoló vonalak

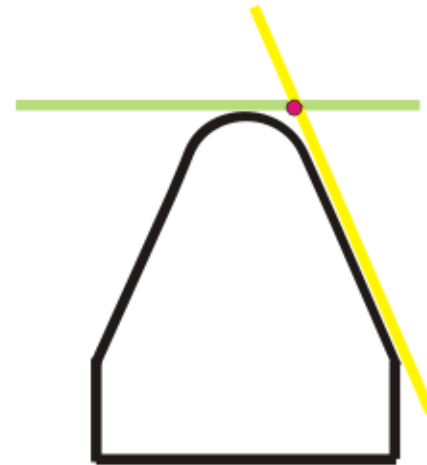
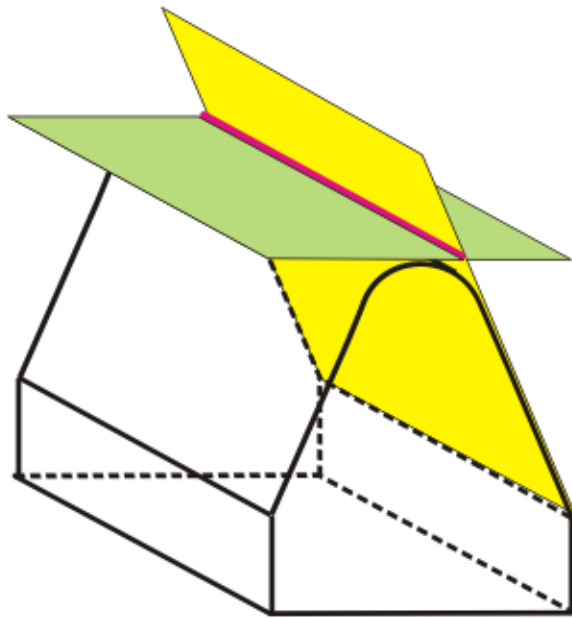

# Tagoló vonalak

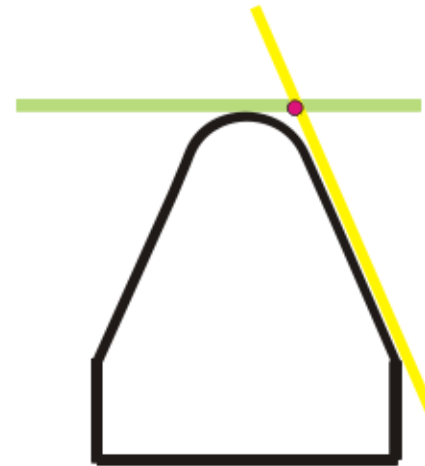
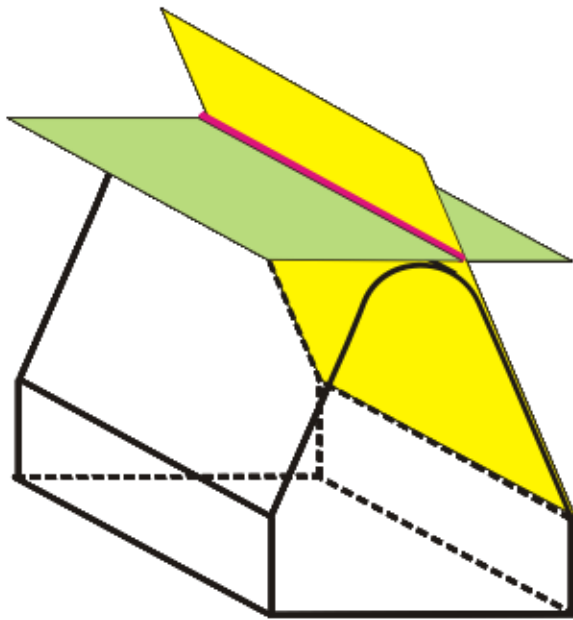

# Tagoló vonalak

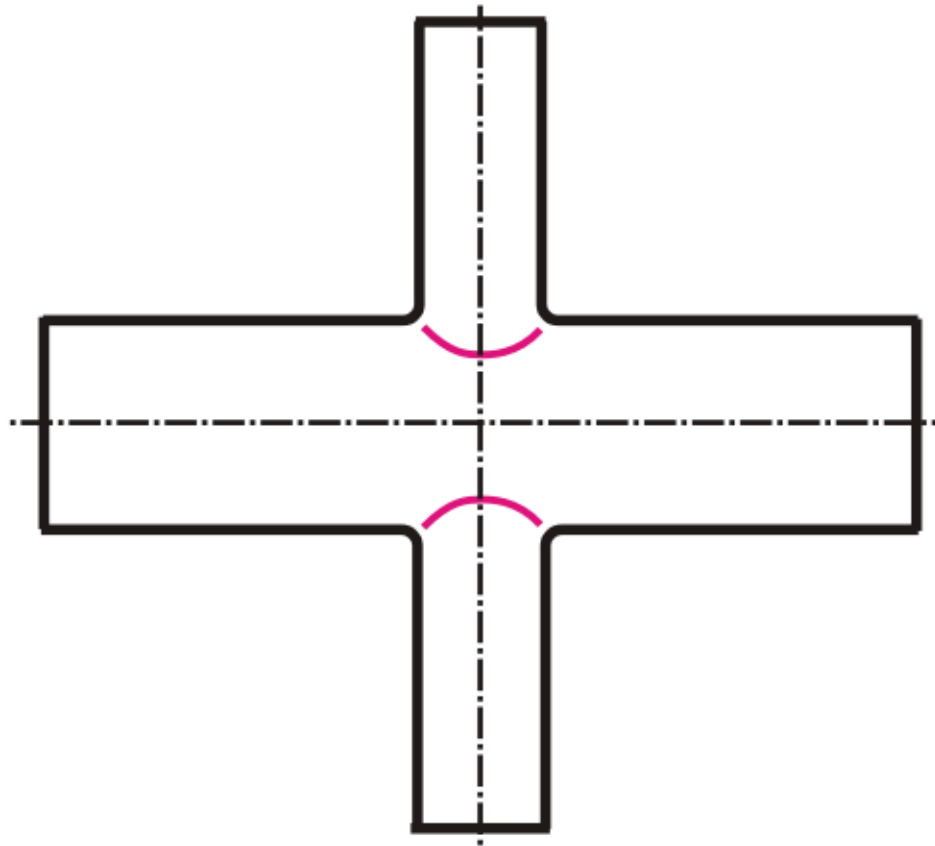

# Méretvonalak

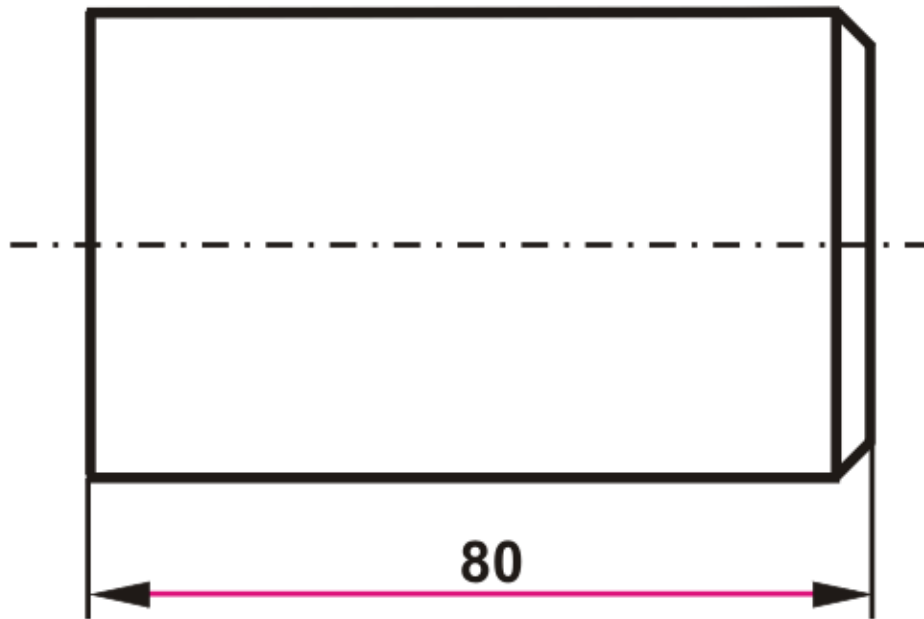



# Méret-segédvonalak

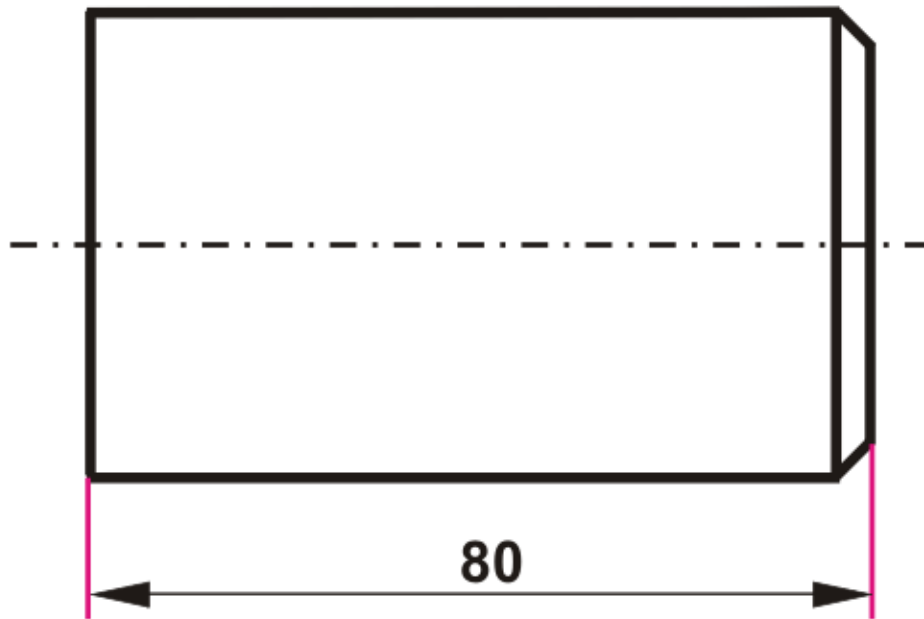

# Mutatóvonalak

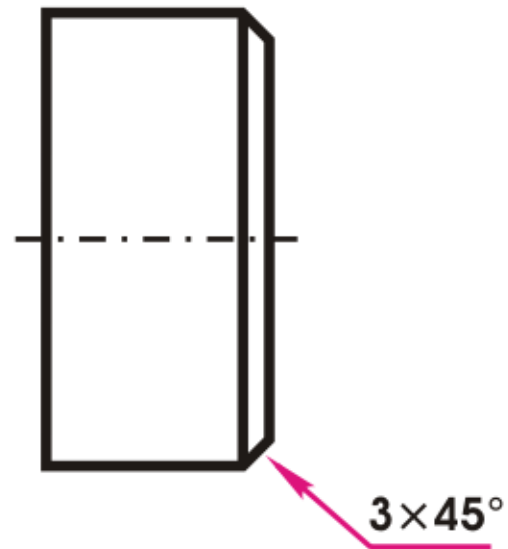
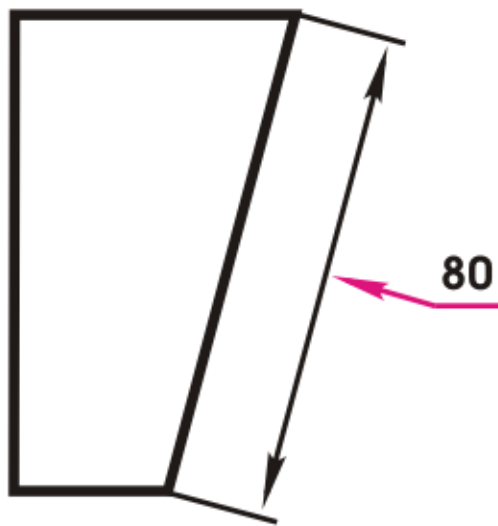

# Vonalkázás (sraffozás)

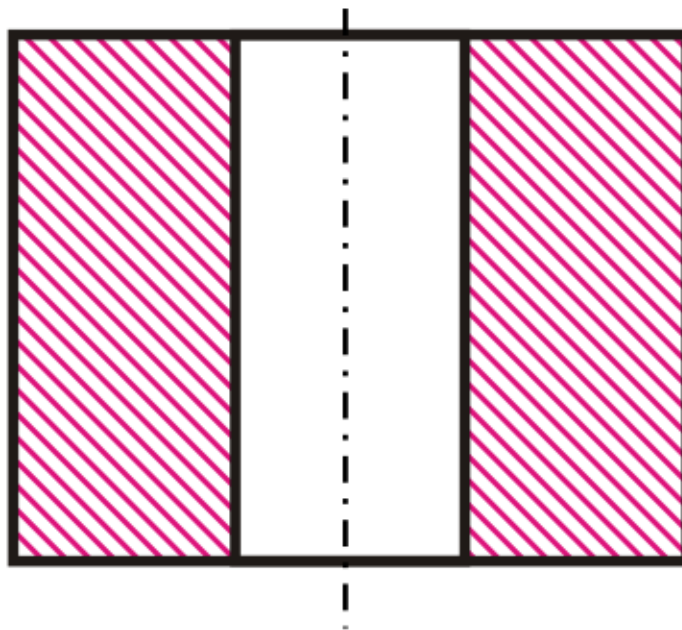

# Ismétlődő elemek belső burkolóvonalala

Menetes orsó

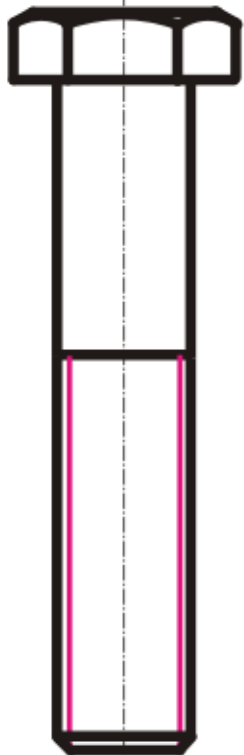

Fogaskerék

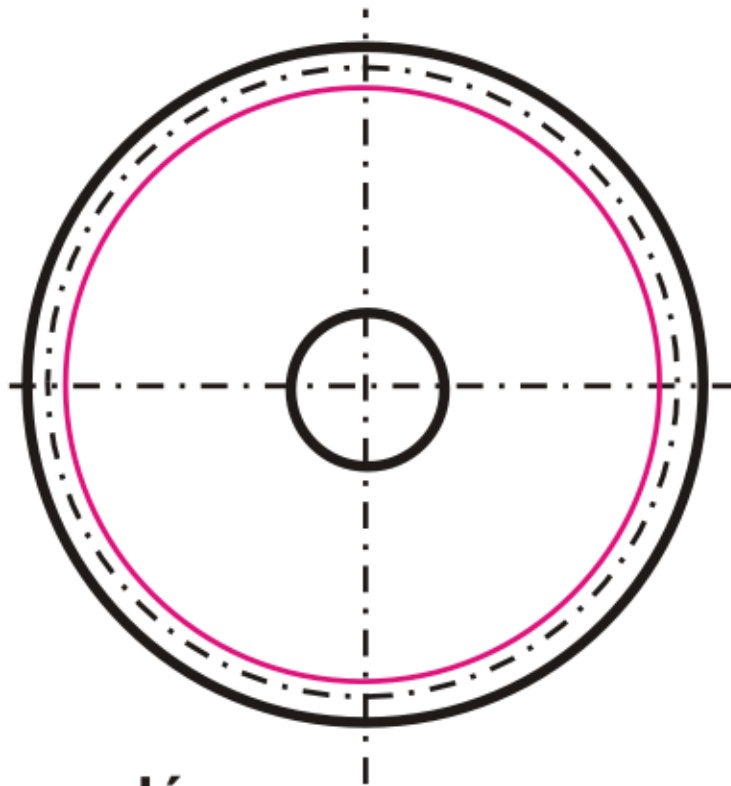

Fogasléc



**Pont-vonalak**

# A pont-vonalak rajzolata

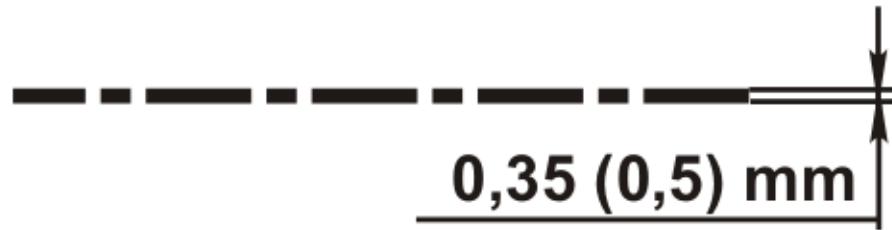

# Forgástestek tengelye (középvonala)

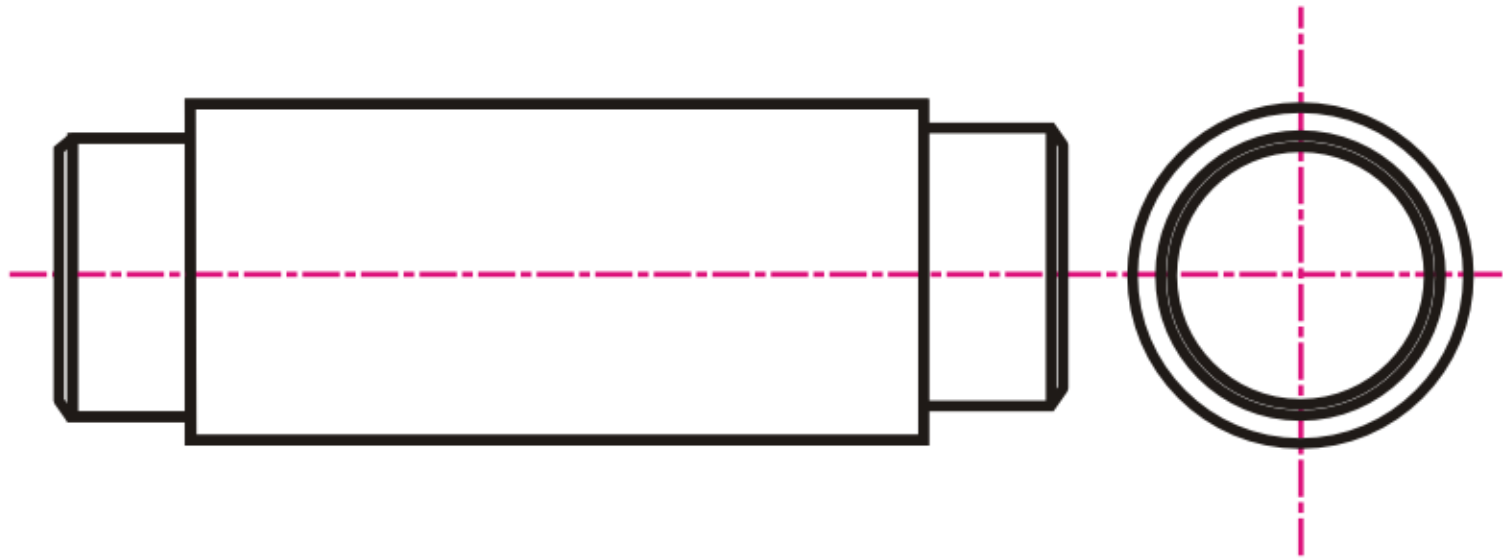

# Szimmetrikus alkatrészek középvonala

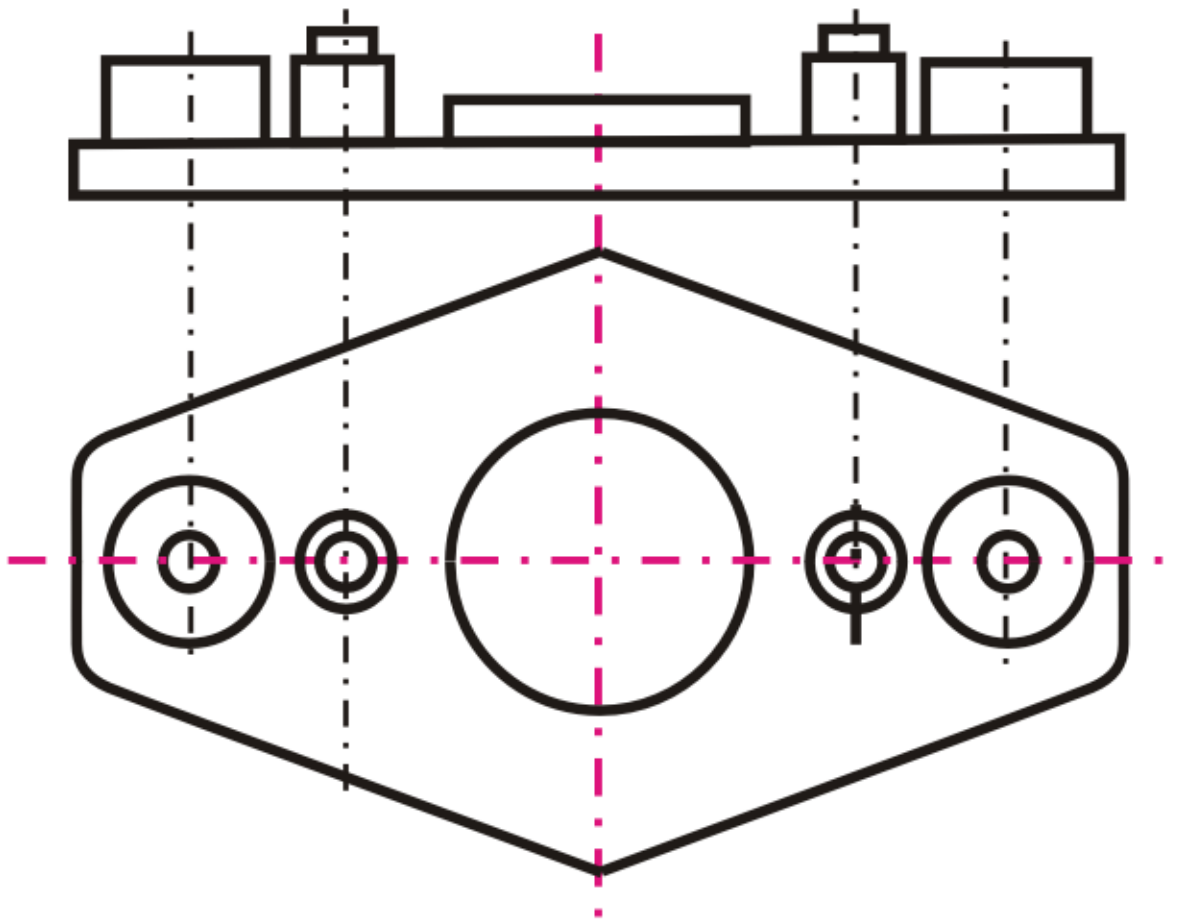



# Osztókörök középvonala

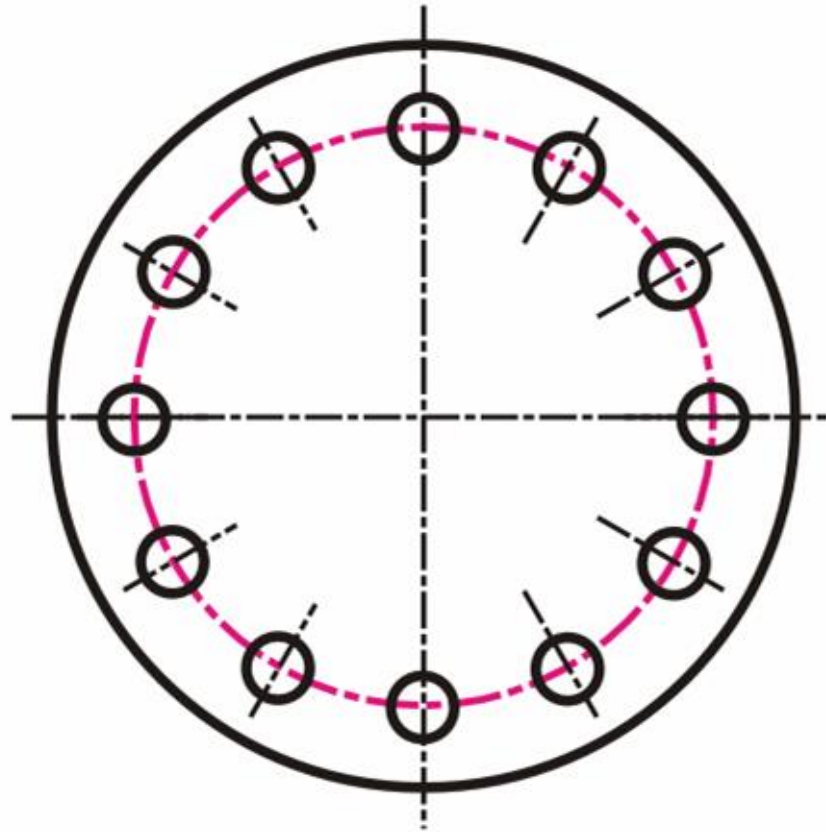

# Furatok középvonala és szimmetria-tengelyei

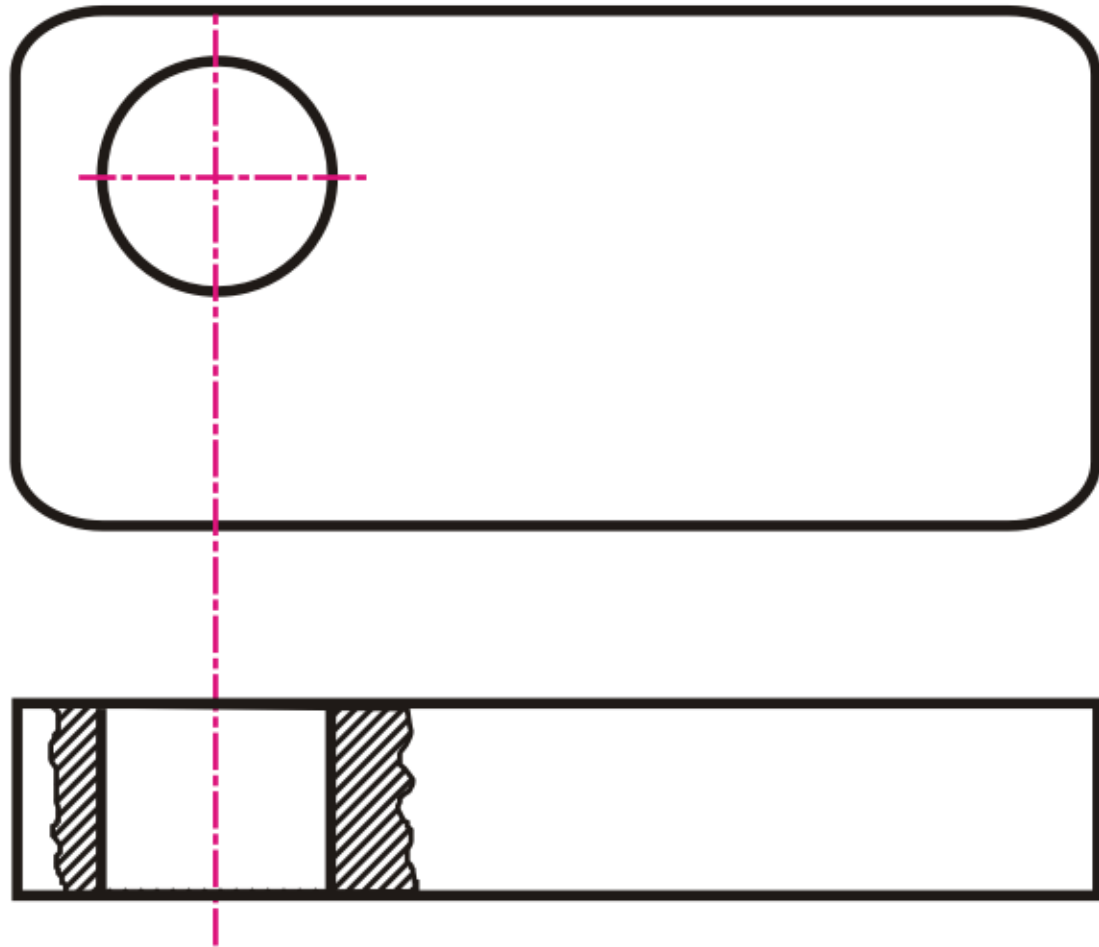

# Szelvények nyomvonalára

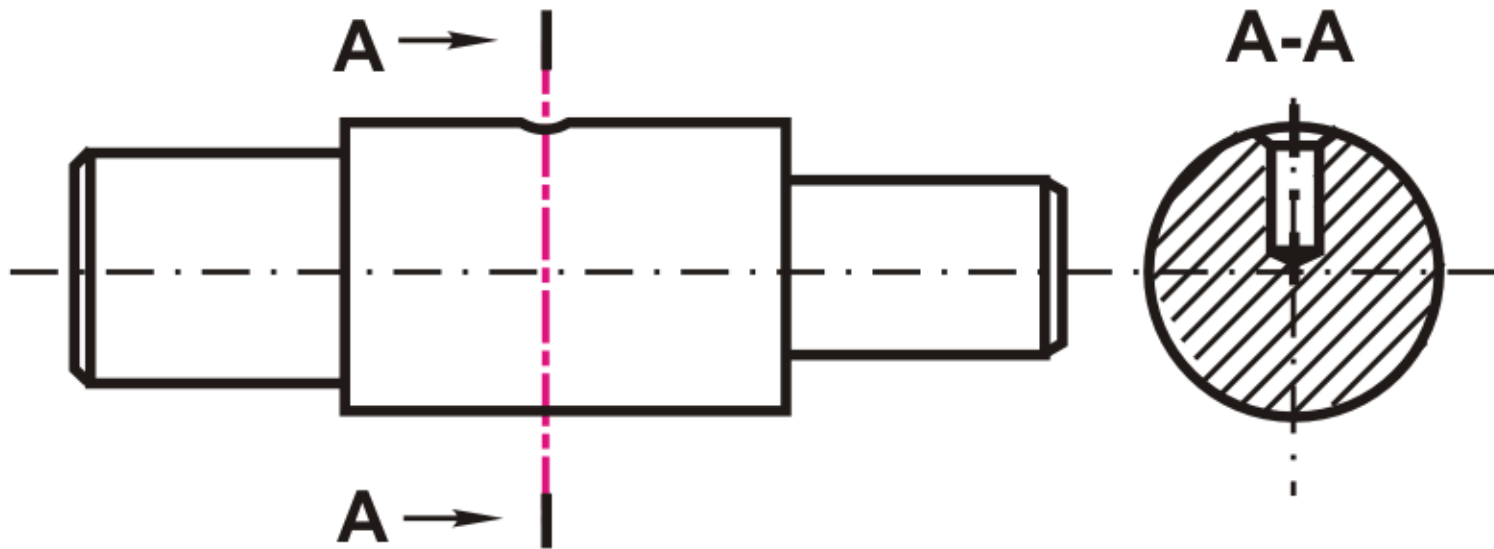

# Kétpont-vonalak

# A két-pont-vonalak rajzolata

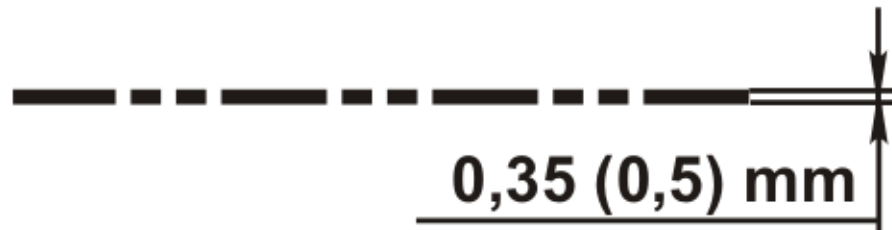

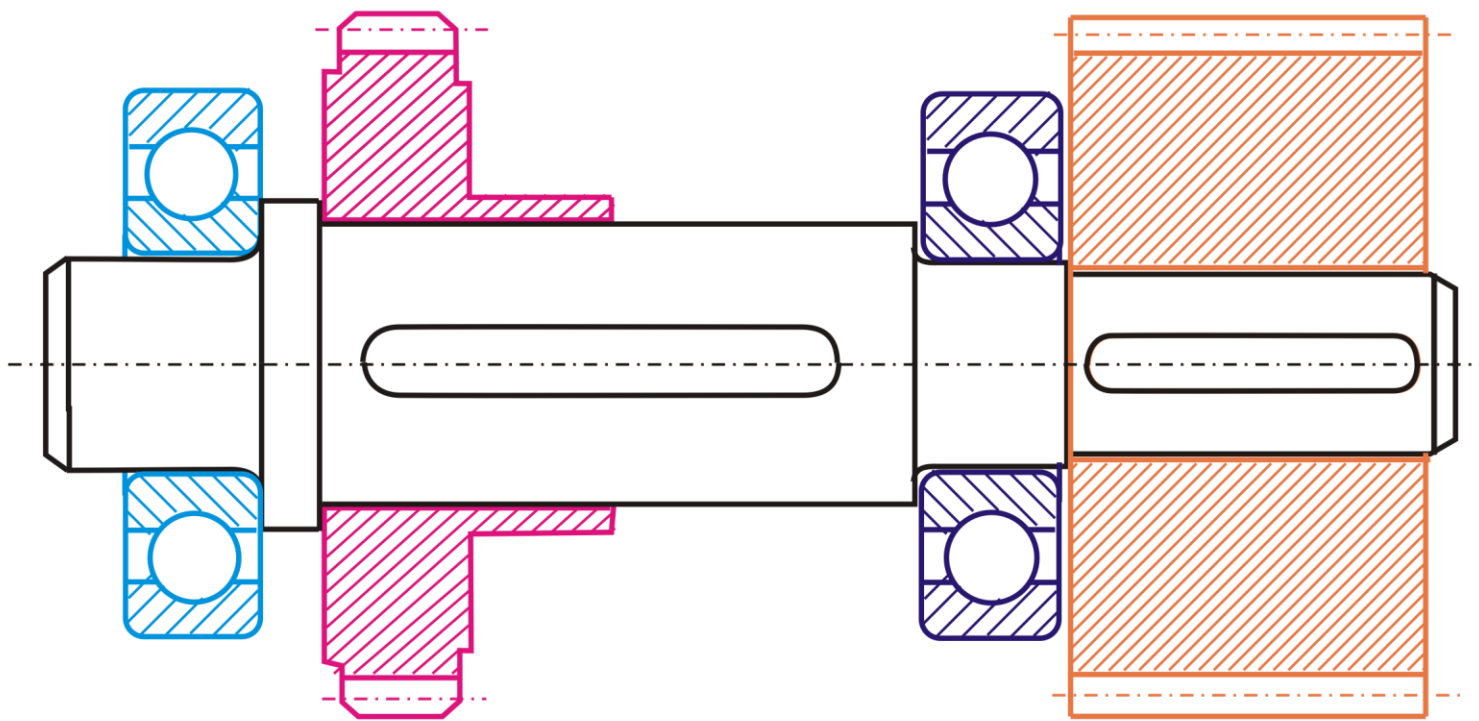

# Mozgó alkatrészek szélső helyzetei

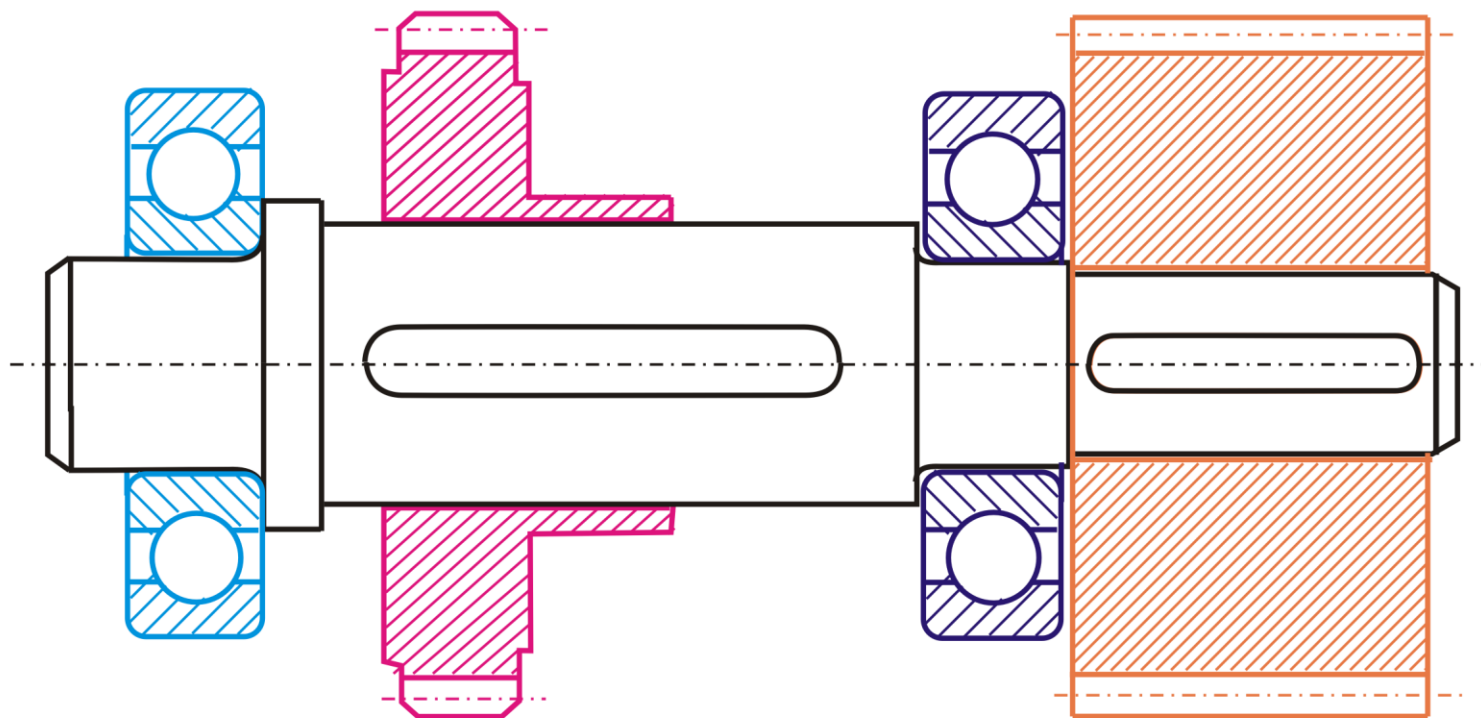

# Mozgó alkatrészek szélső helyzetei

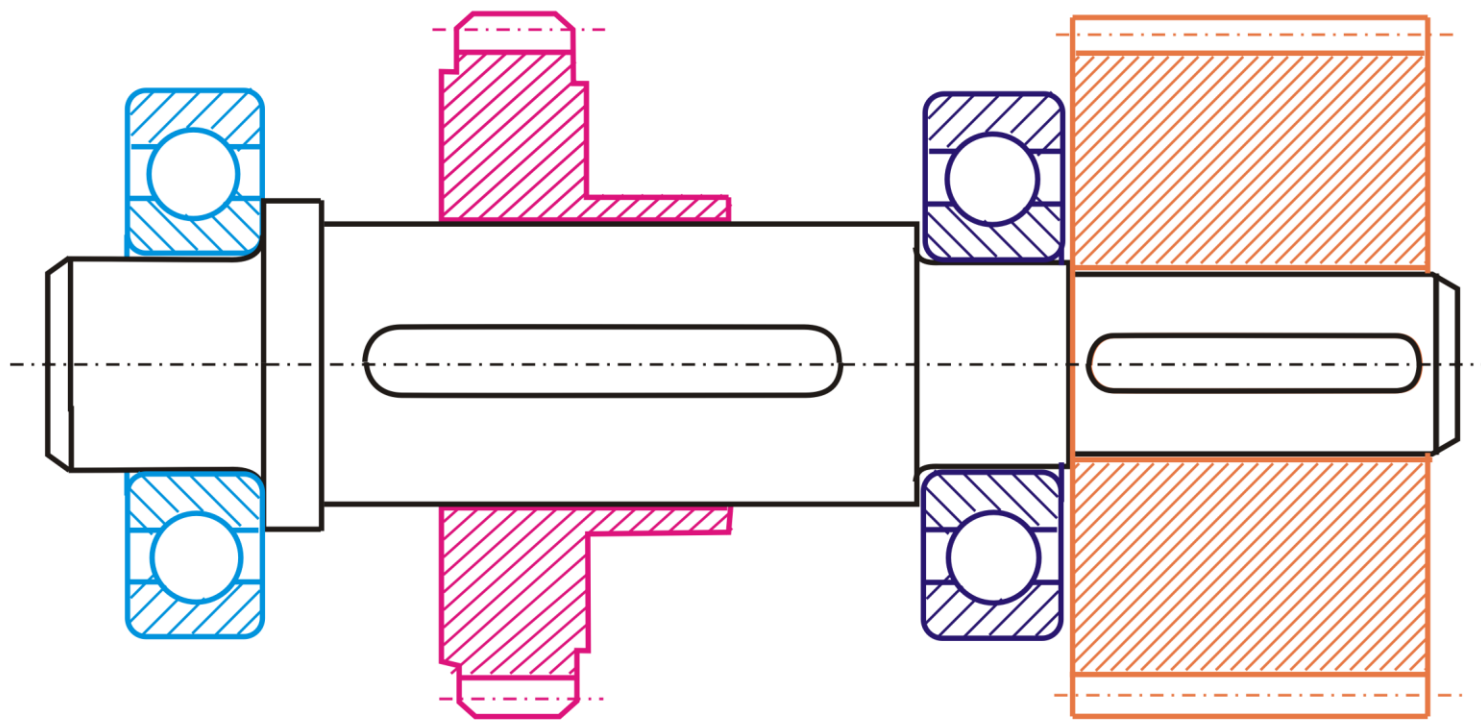



# Mozgó alkatrészek szélső helyzetei

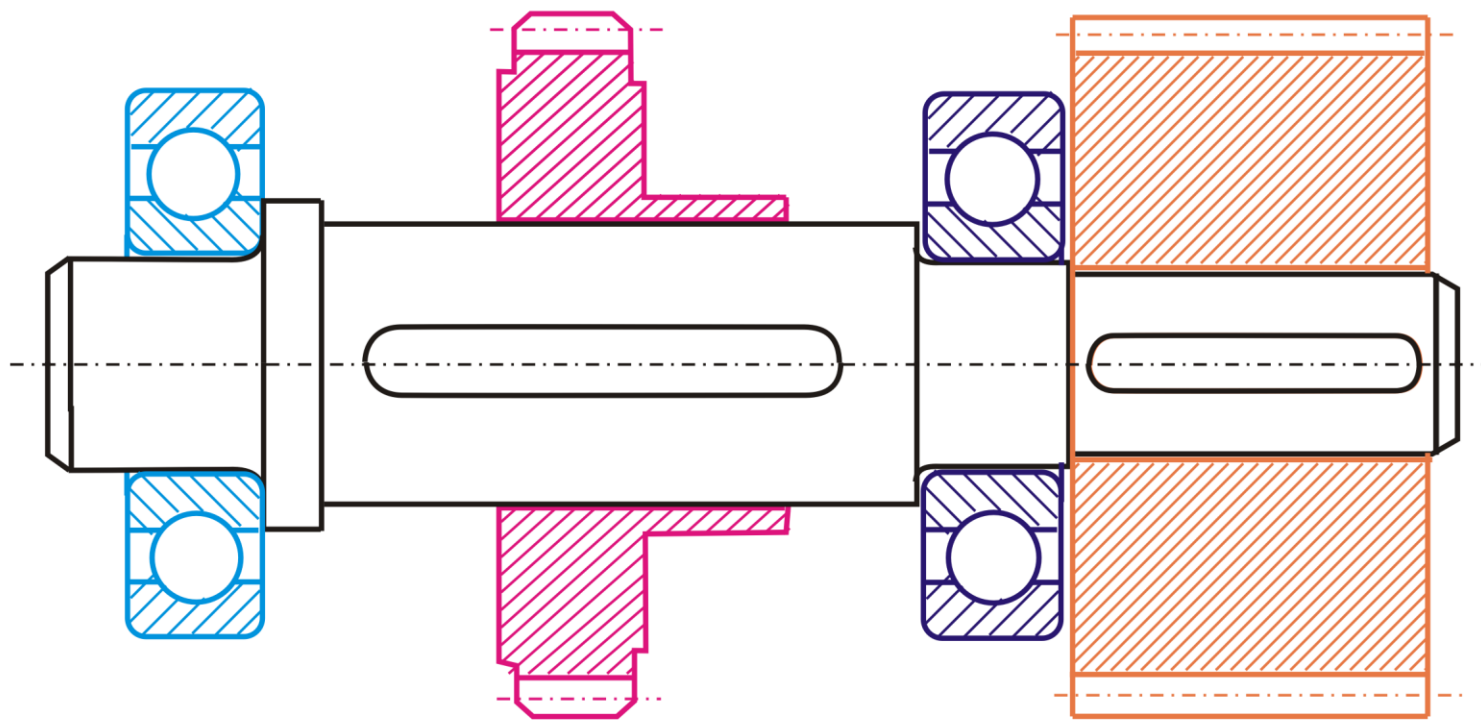

# Mozgó alkatrészek szélső helyzetei

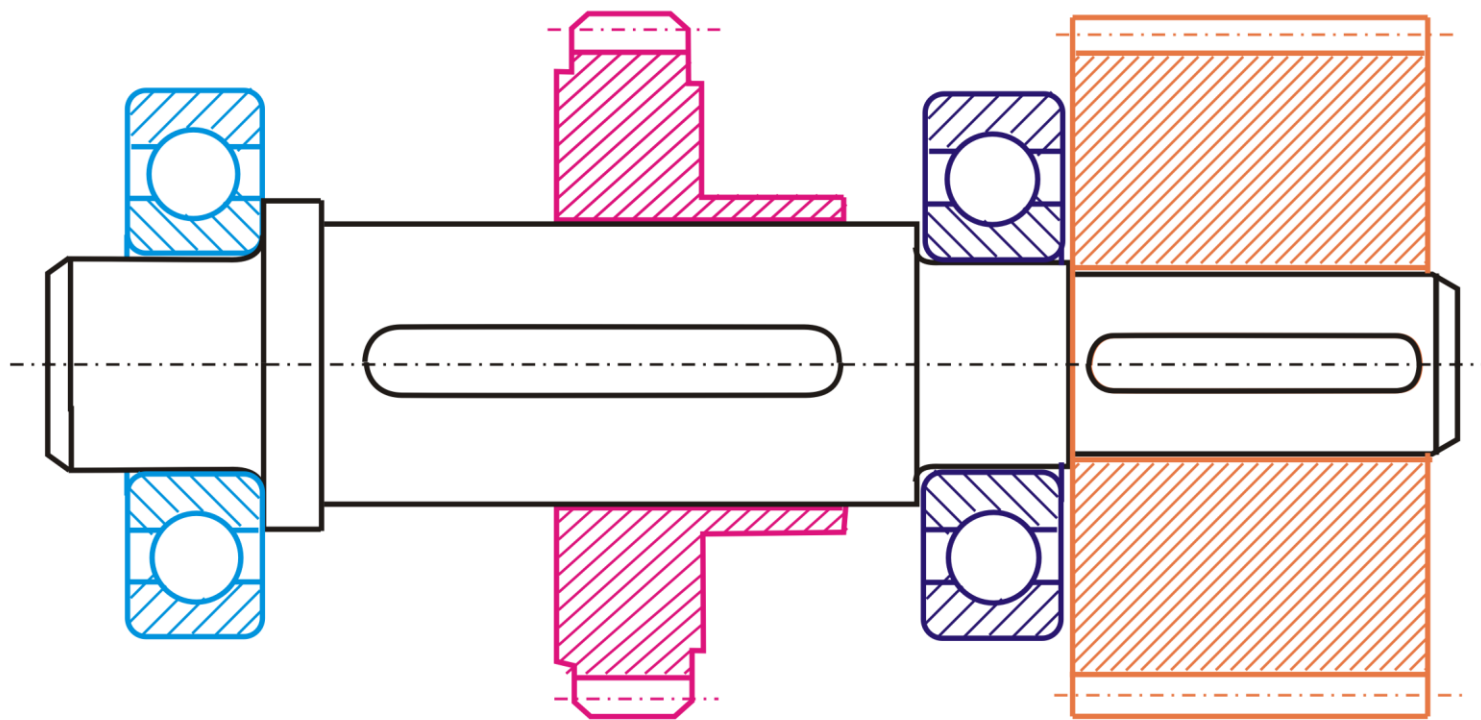

# Mozgó alkatrészek szélső helyzetei

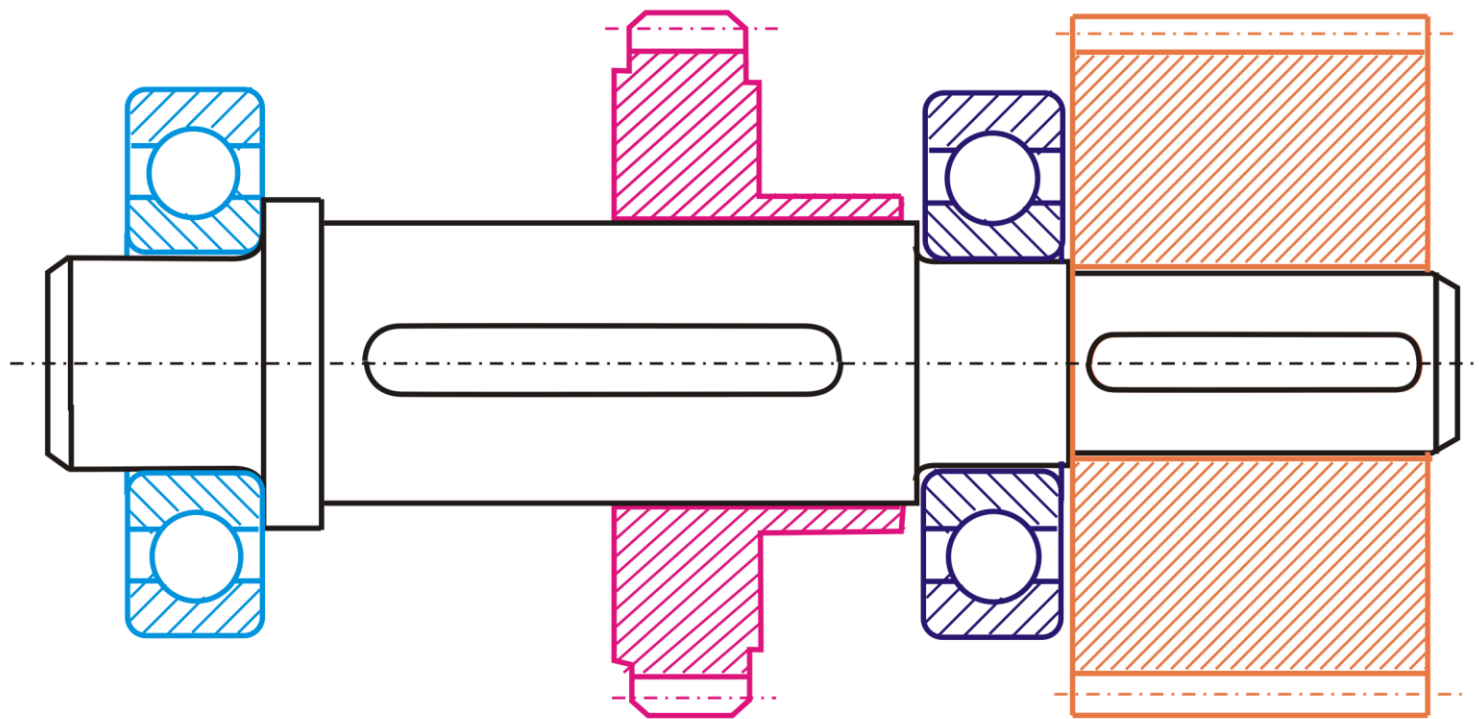

# Mozgó alkatrészek szélső helyzetei

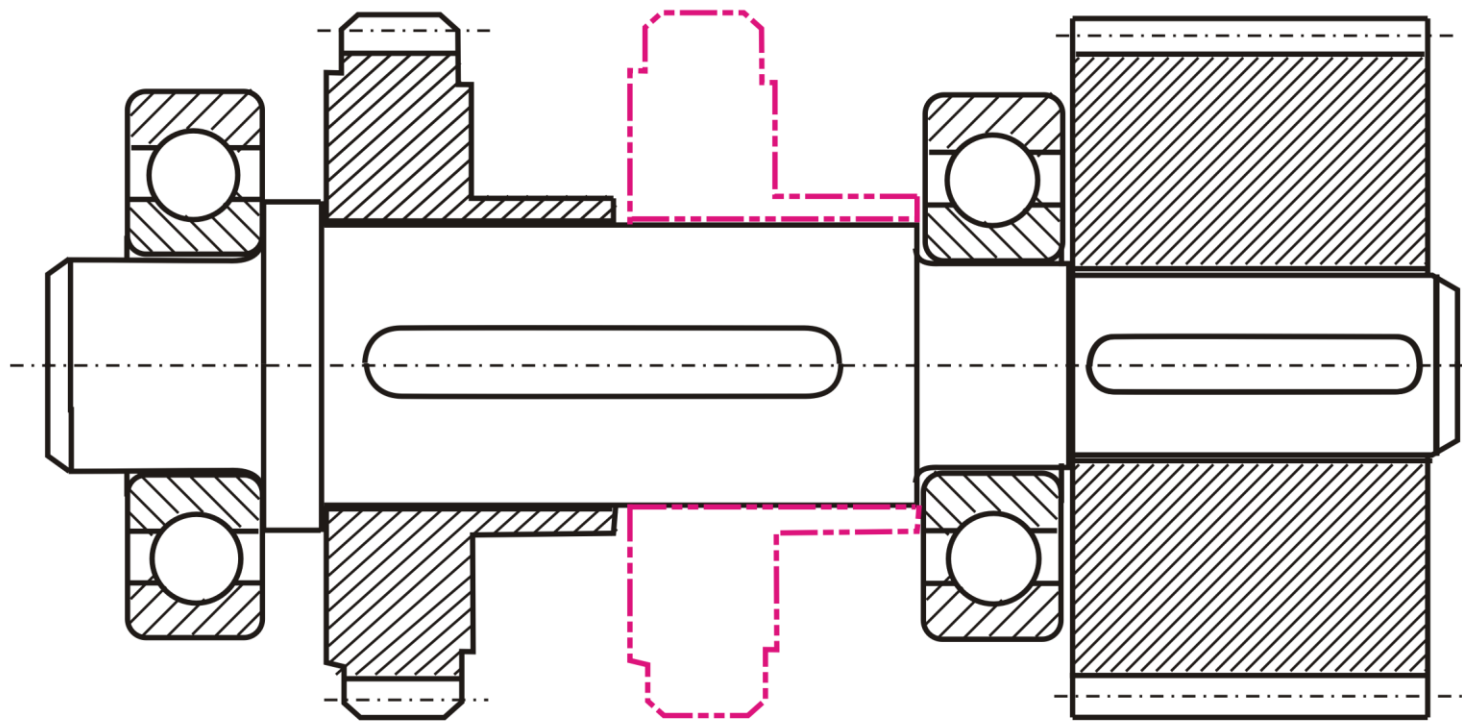

# Csatlakozó alkatrészek körvonalala

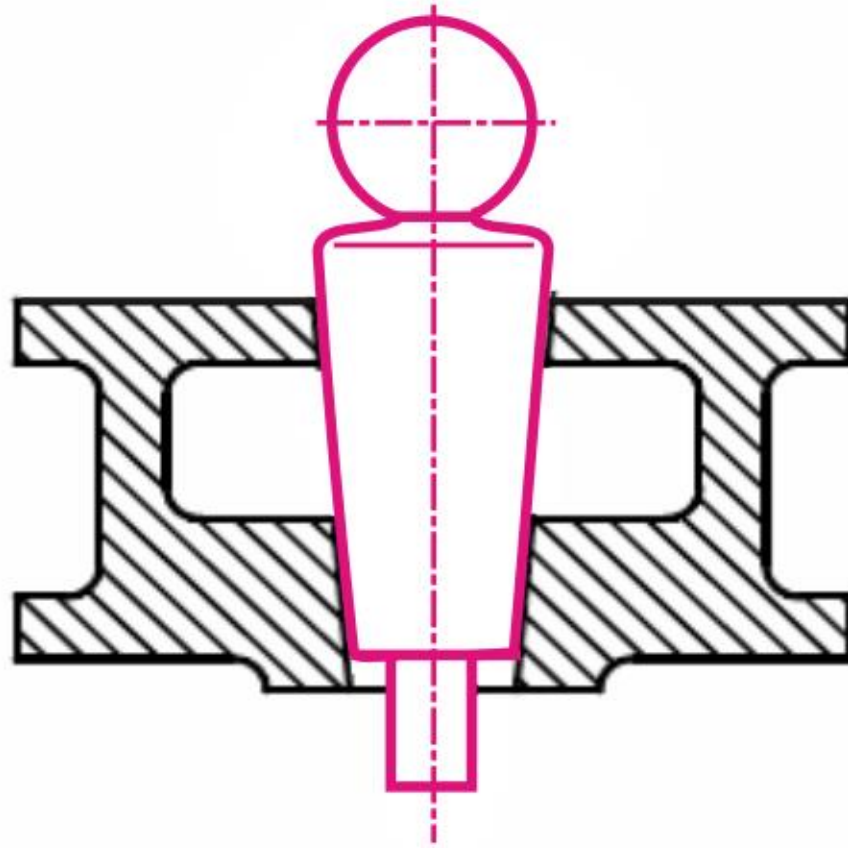

# Csatlakozó alkatrészek körvonalala

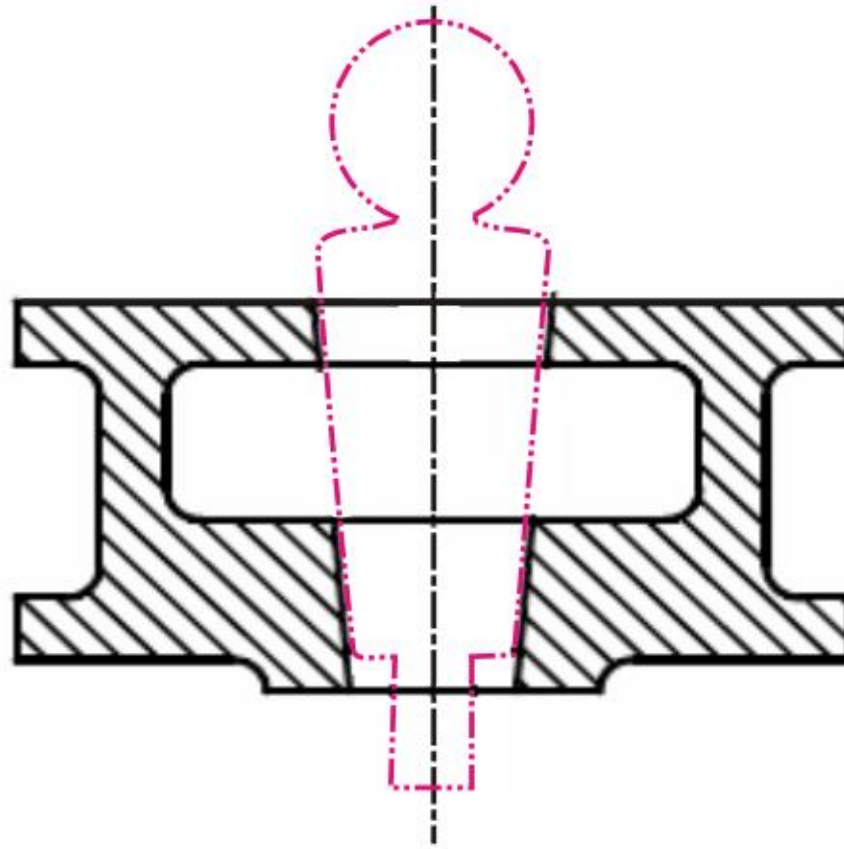

# Alkatrész kiterített (gyártás előtti) alakjának körvonala



# Alkatrész kiterített (gyártás előtti) alakjának körvonalala

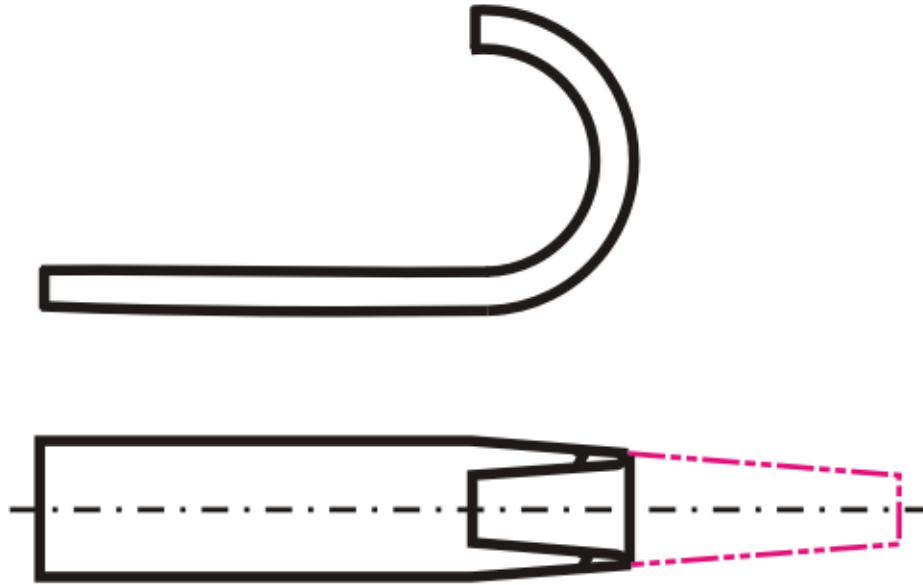



**Szaggatott vonalak**

# A szaggatott vonalak rajzolata

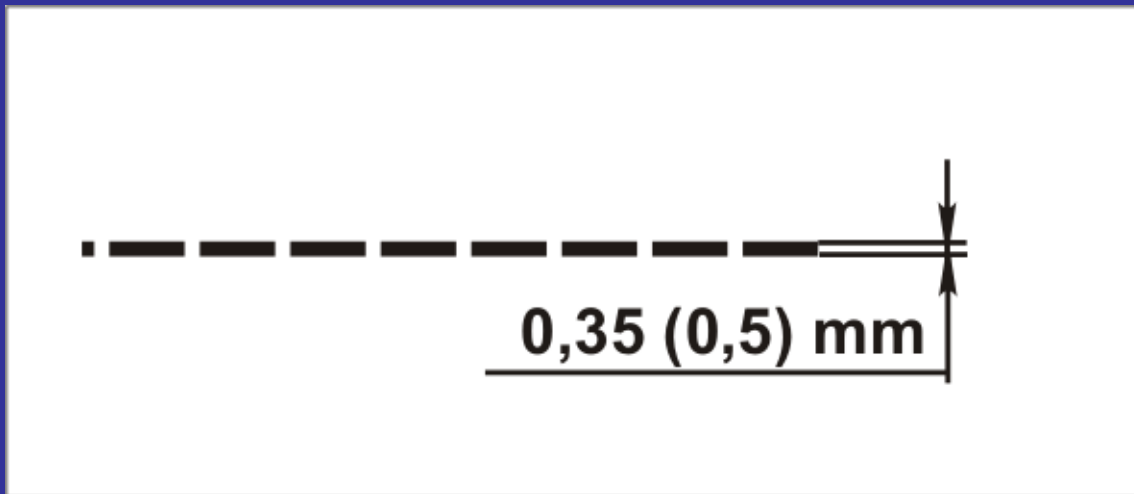

Nem látható, de az egyértelműséghez fontos élek ábrázolása (kerülni kell!)

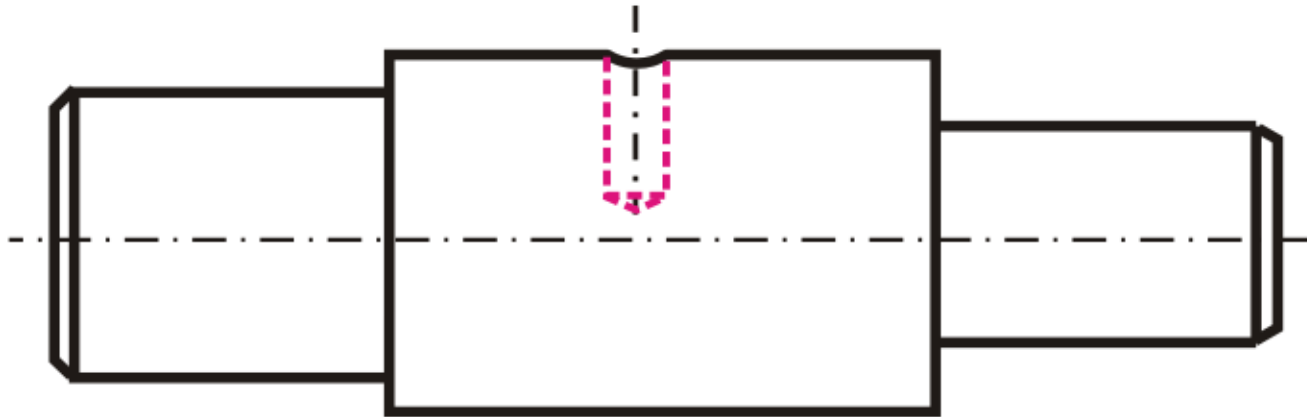

**Szabadkézzel rajzolt (tört)  
vonalak**

# A törtvonalalak rajzolata



# Alkatrész elhagyott részének határa

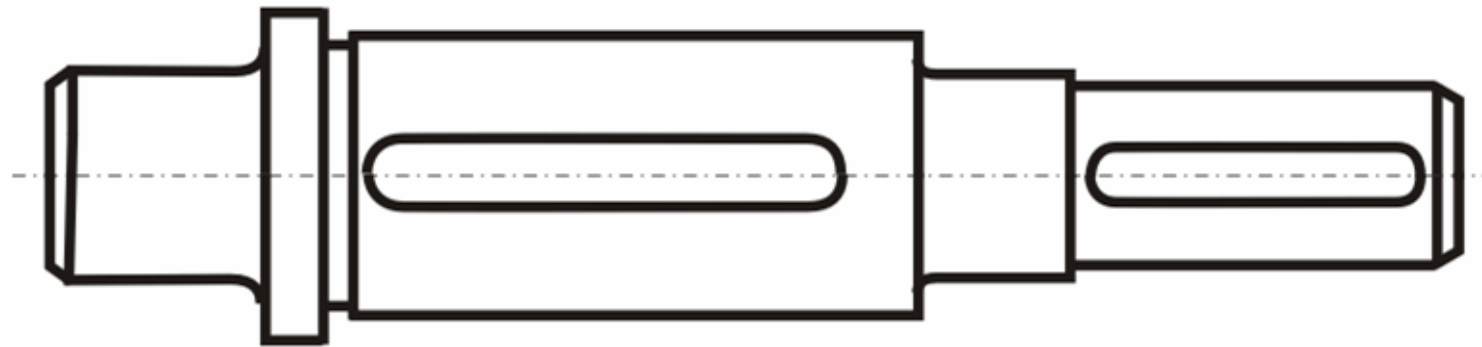

# Alkatrész elhagyott részének határa

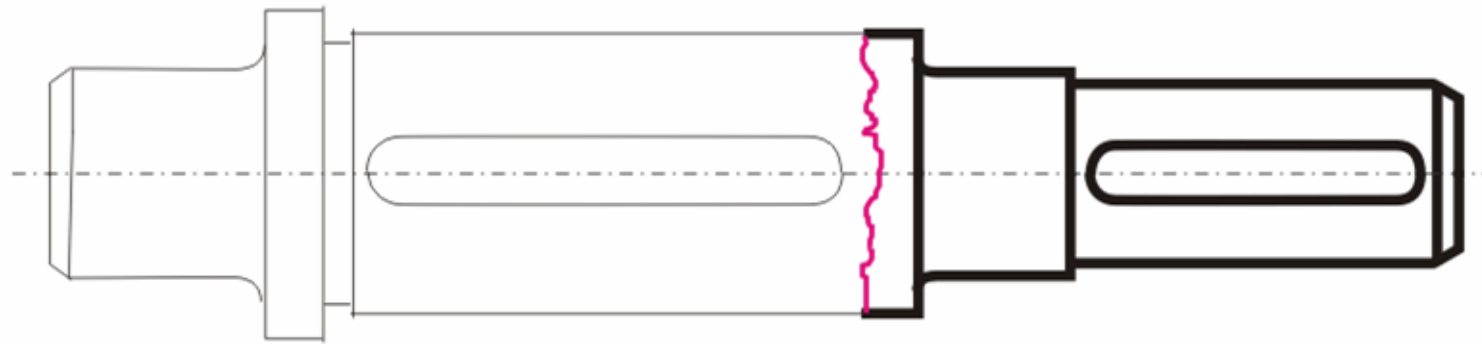

# Alkatrész elhagyott részének határa

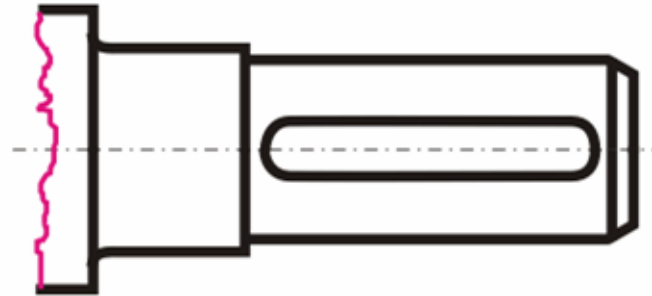



# Kitörés határa

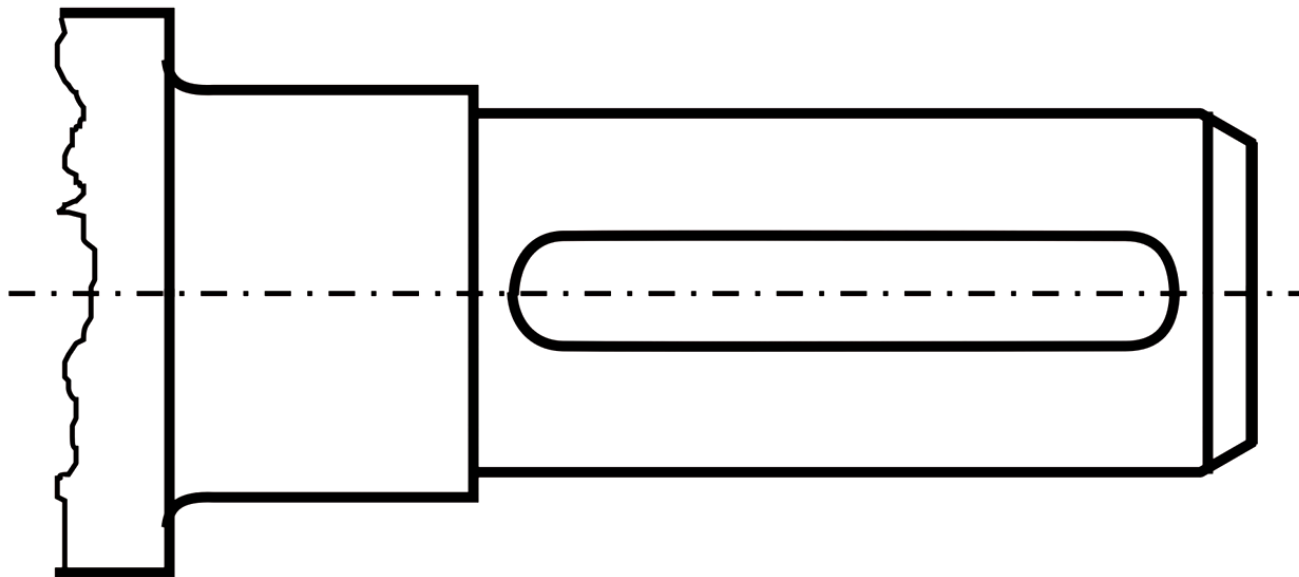

# Kitörés határa

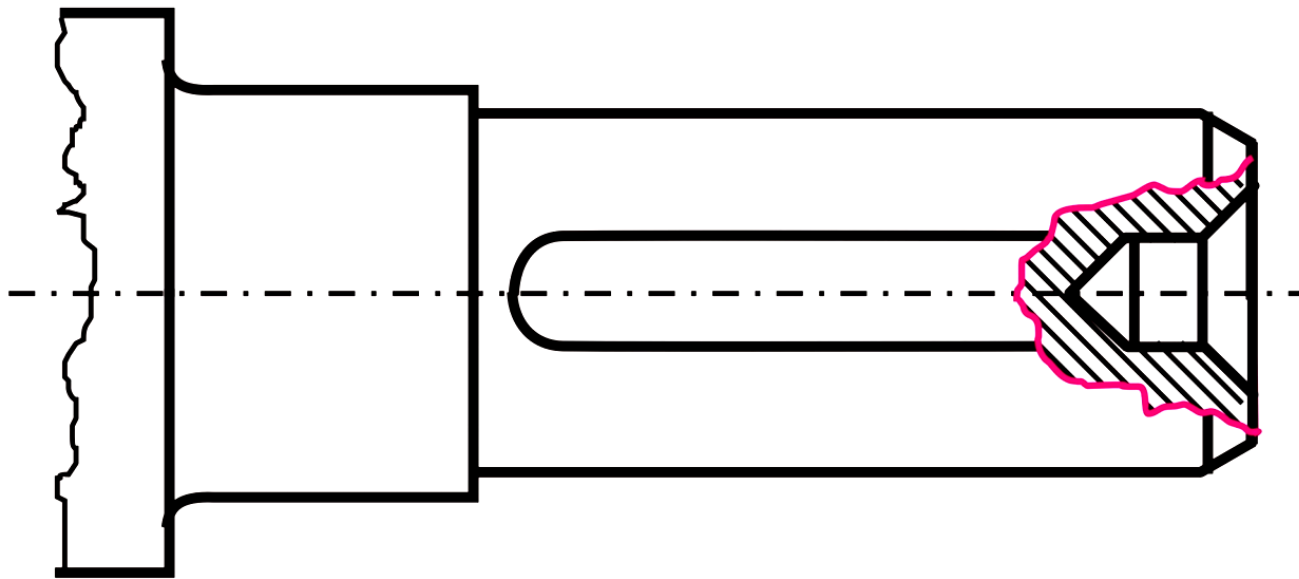

# Résznézet határvonala

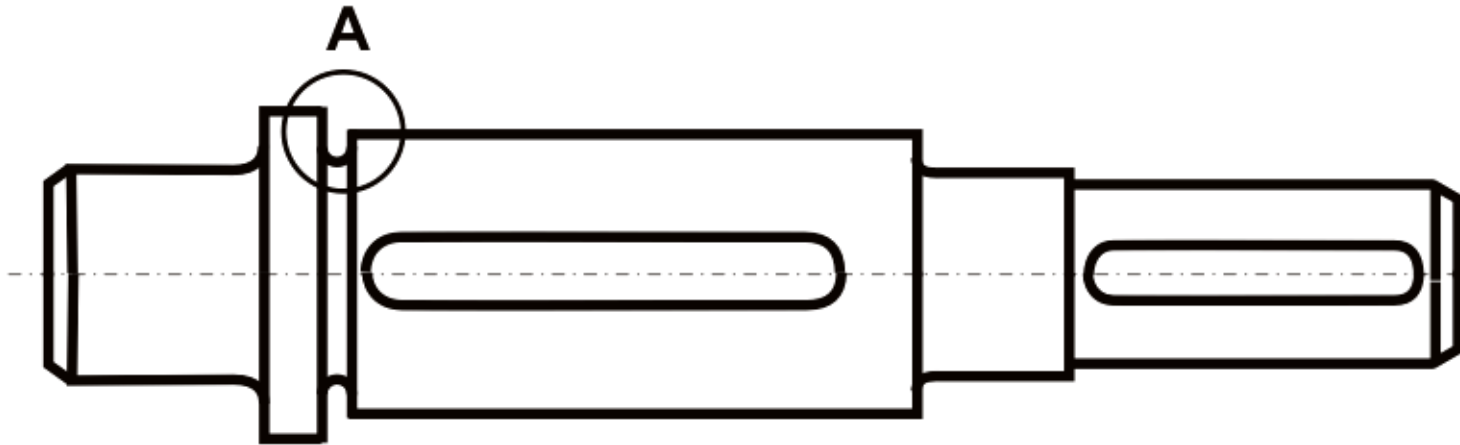

A (2:1)

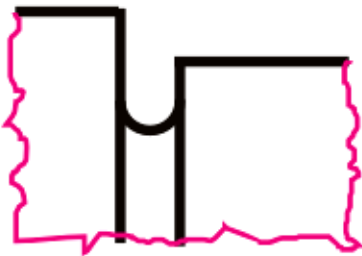

# RAJZOLÁSI EGYSZERÜSÍTÉSEK

# Szimmetrikus tárgyak egyszerűsített ábrázolása

# Félnézet

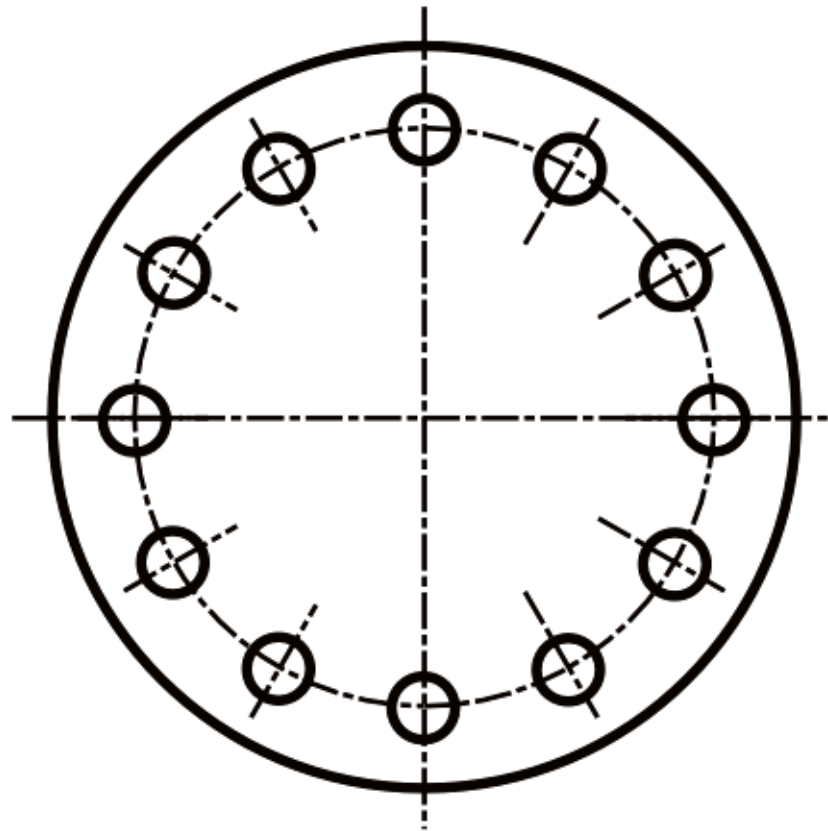

# Félnézet

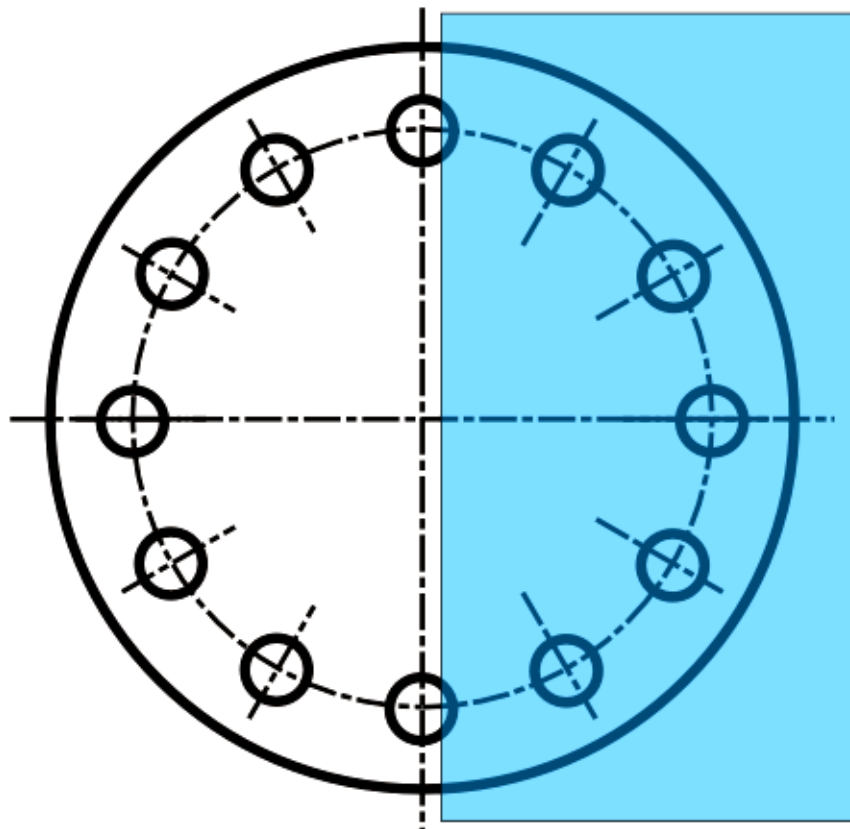

# Félnézet

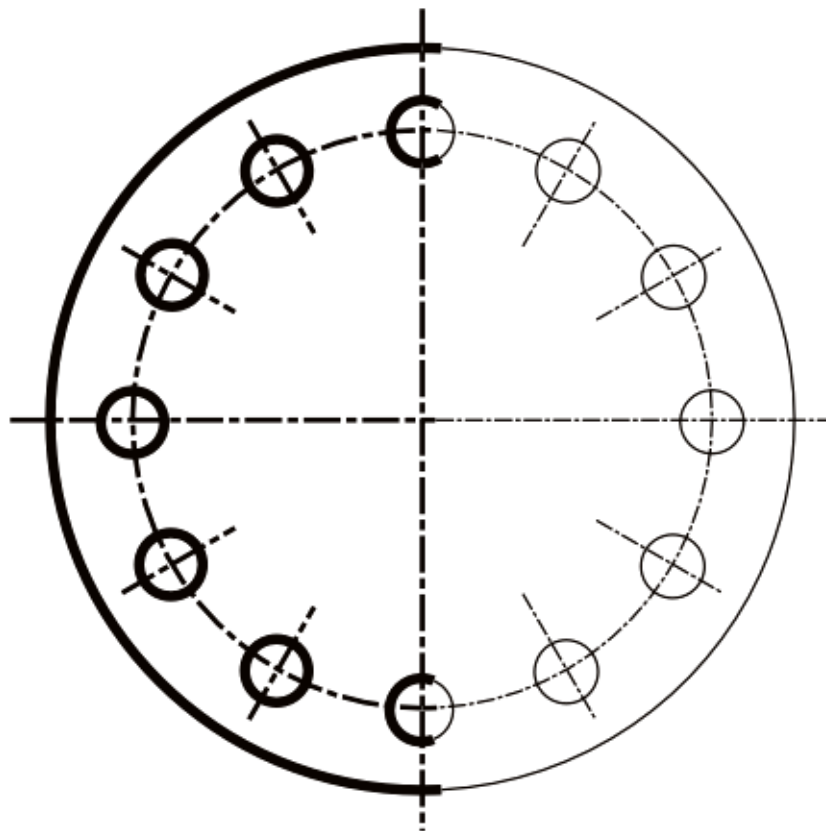



# Félnézet

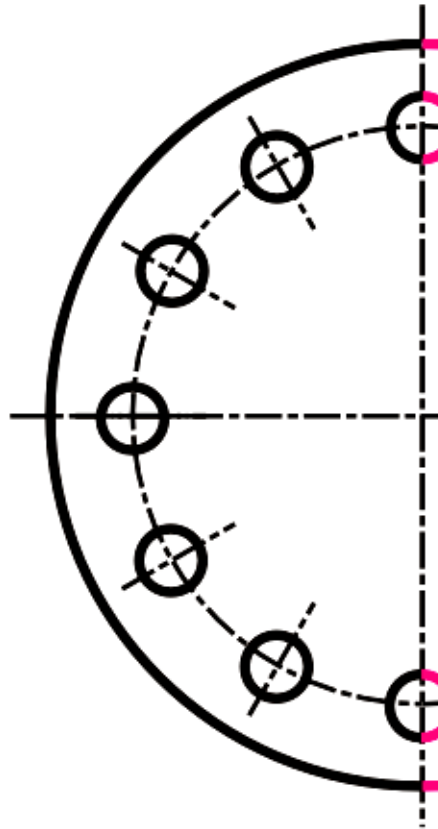

# Félnézet

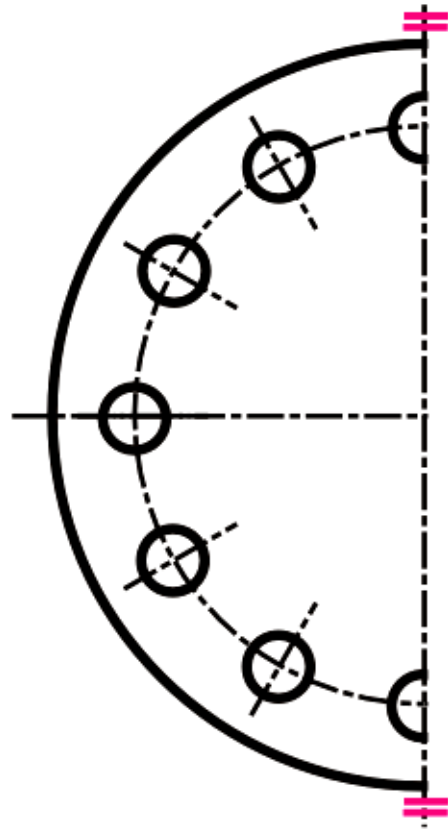

# Ismétlődő elemek „ritkített” ábrázolása

# Ismétlődő furatok

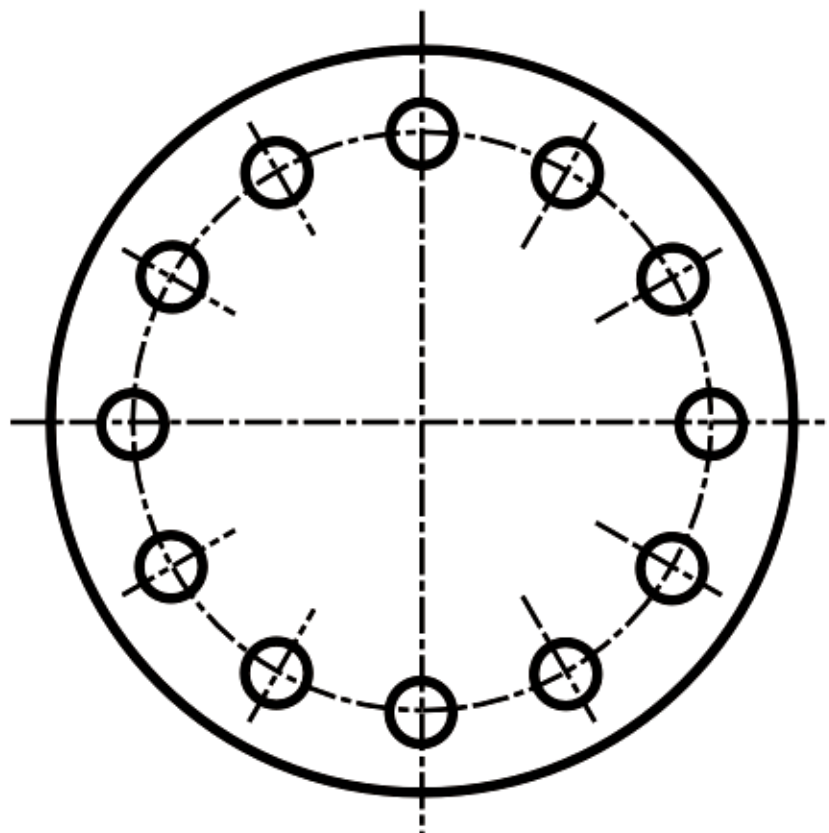

# Ismétlődő furatok

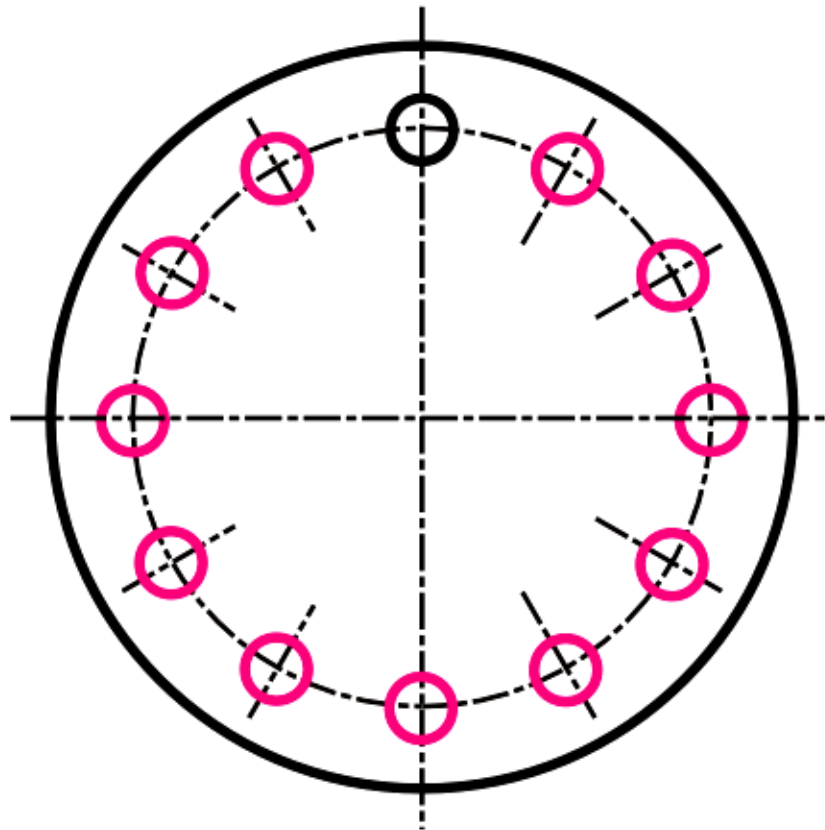

# Ismétlődrő furatok

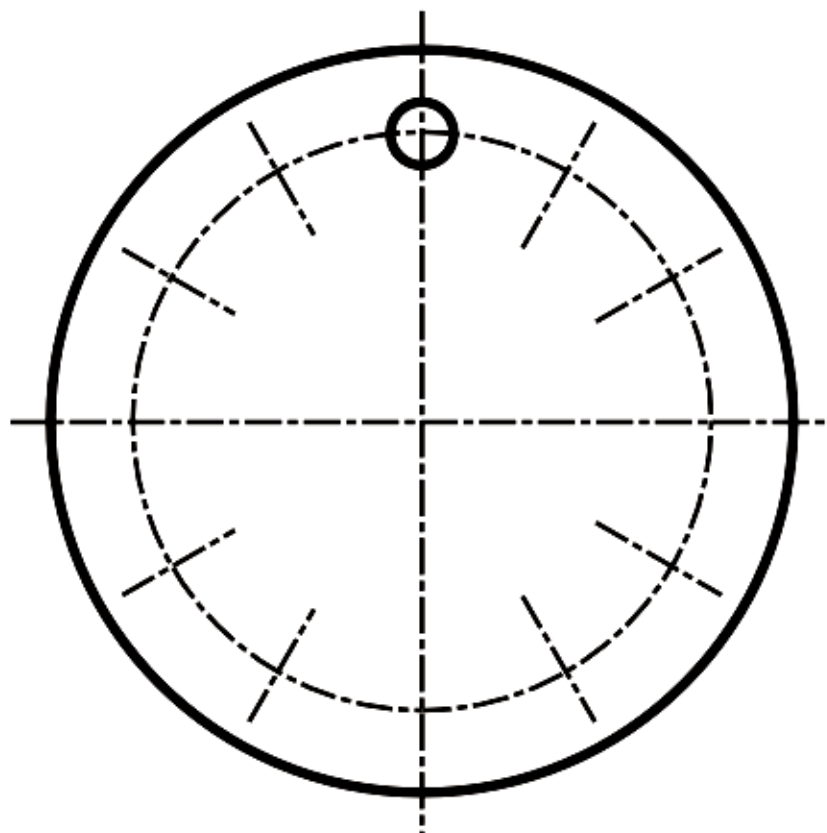

# Ismétlődő mintázat

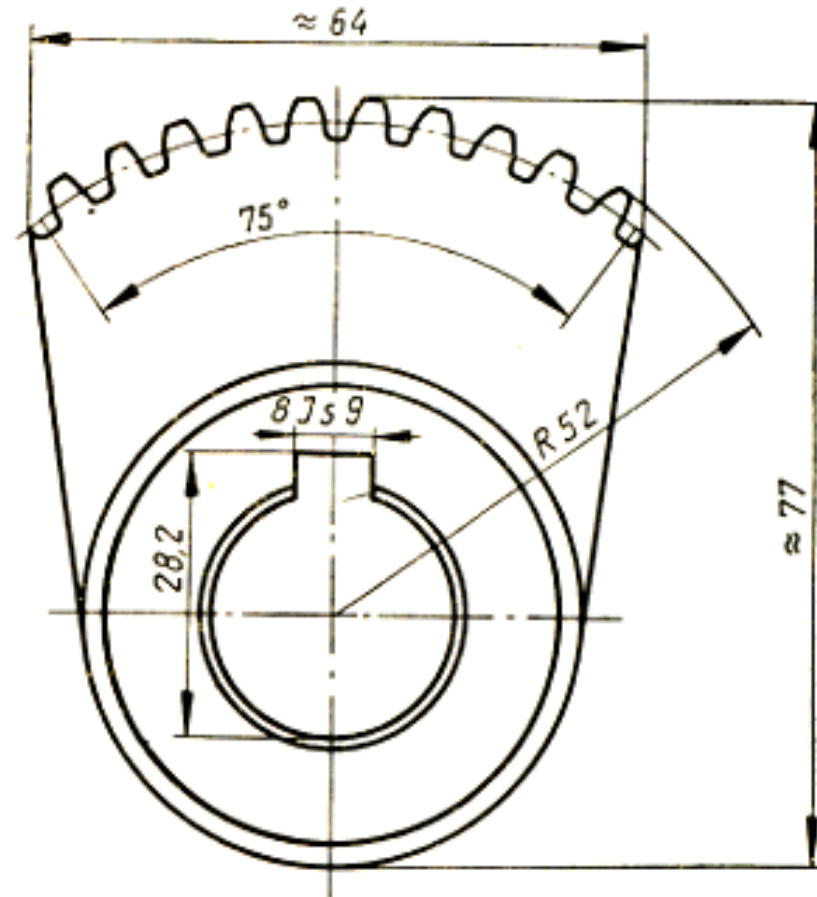

# Ismétlődő mintázat

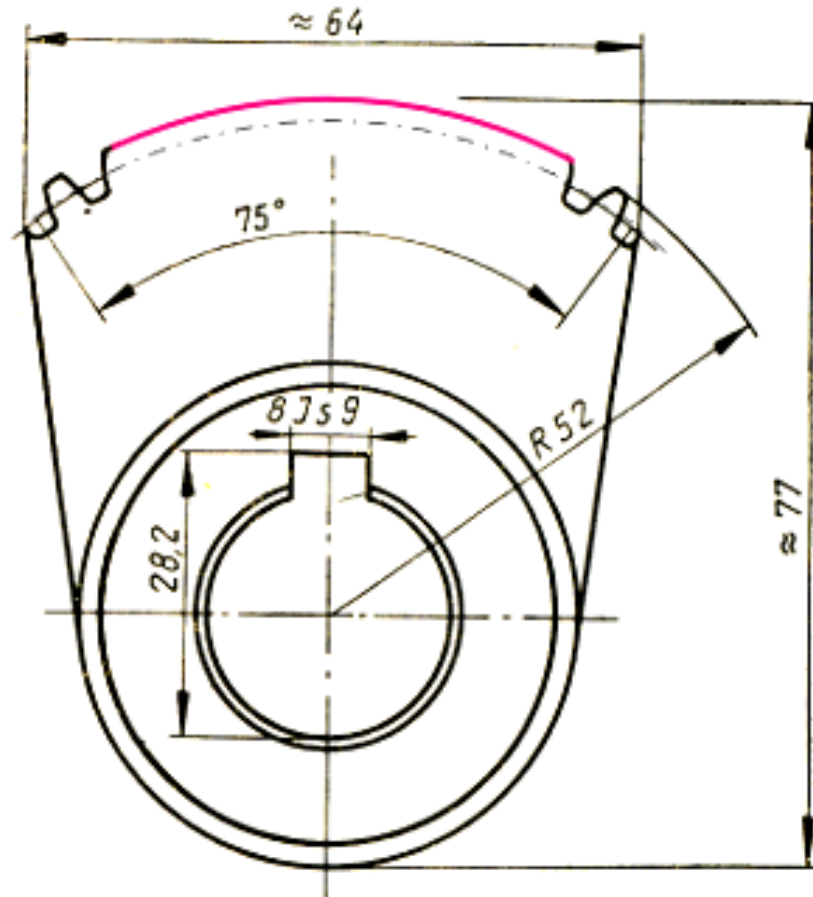



# Ismétlődő mintázat

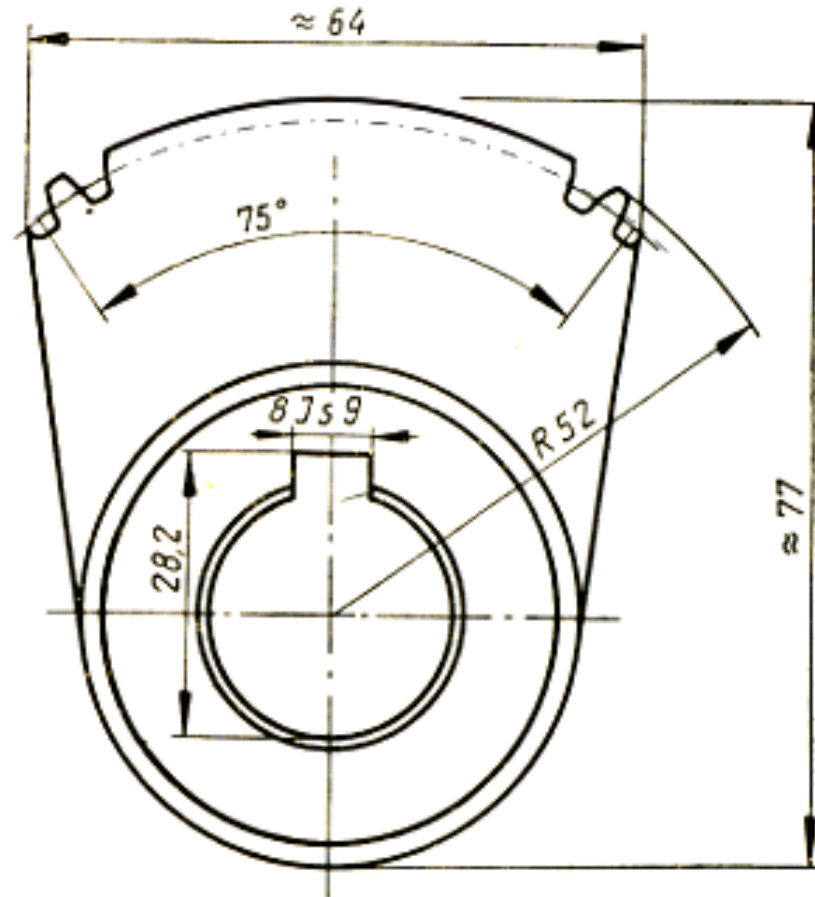

# **Semmitmondó részletek elhagyása**

# Hosszú alkatrészek „kitörése”



# Hosszú alkatrészek „kitörése”

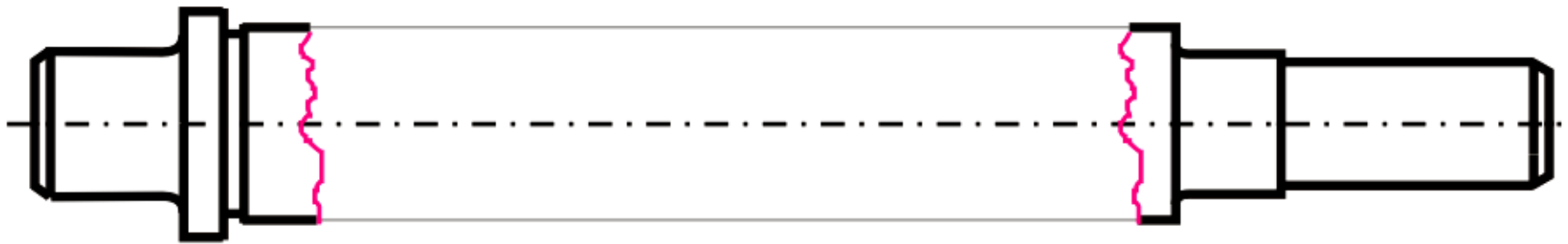

# Hosszú alkatrészek „kitörése”

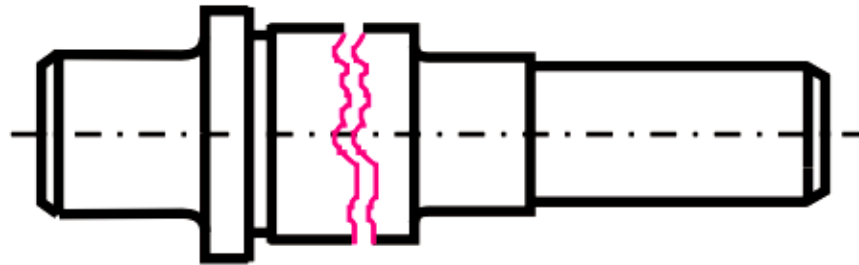

# Sík felületek ábrázolása

# Sík felület ábrázolása

(ha a vetületek nem elegendőek a sík jelleg érzékeltetésére)

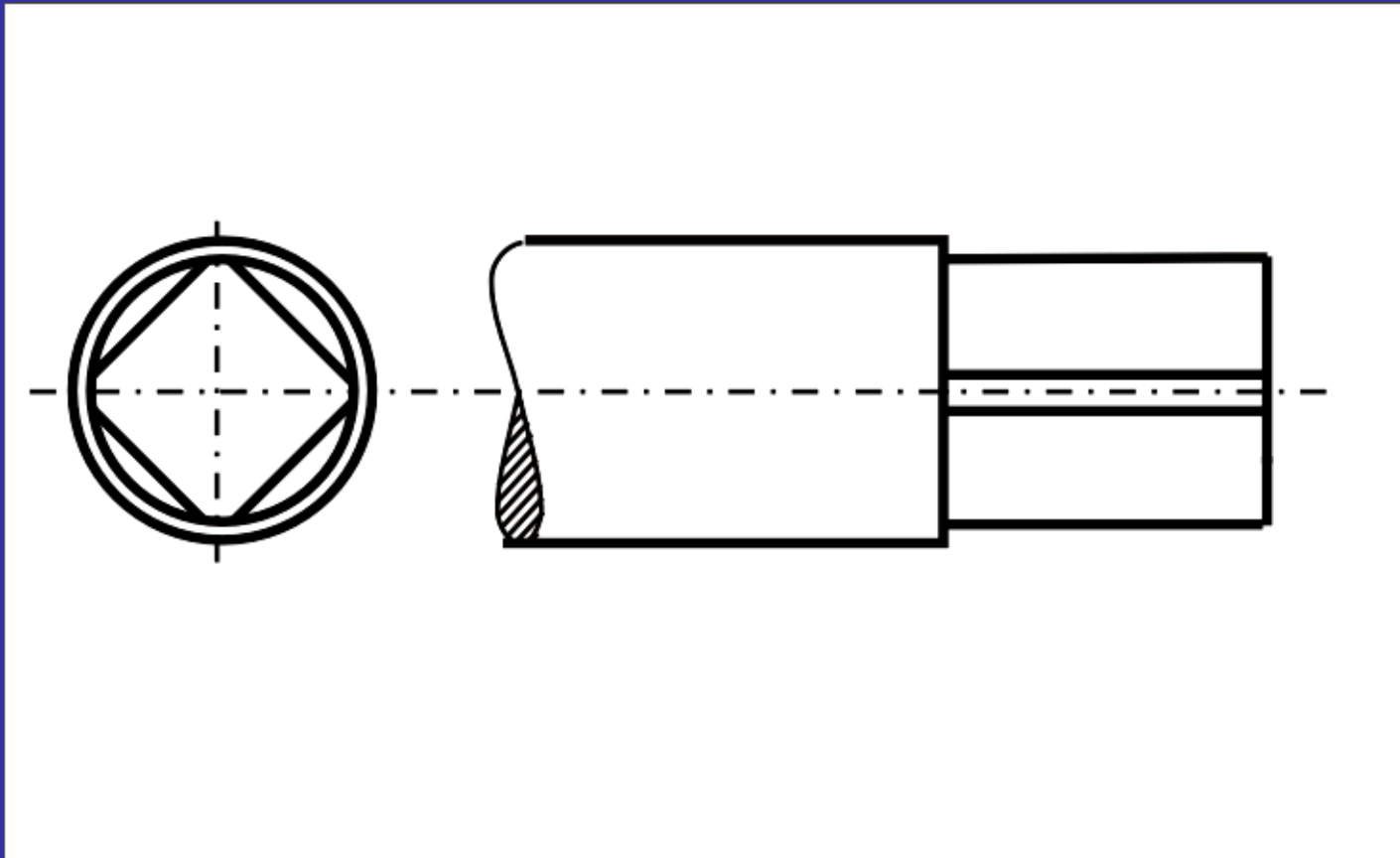

# Sík felület ábrázolása

(ha a vetületek nem elegendőek a sík jelleg érzékeltetésére)

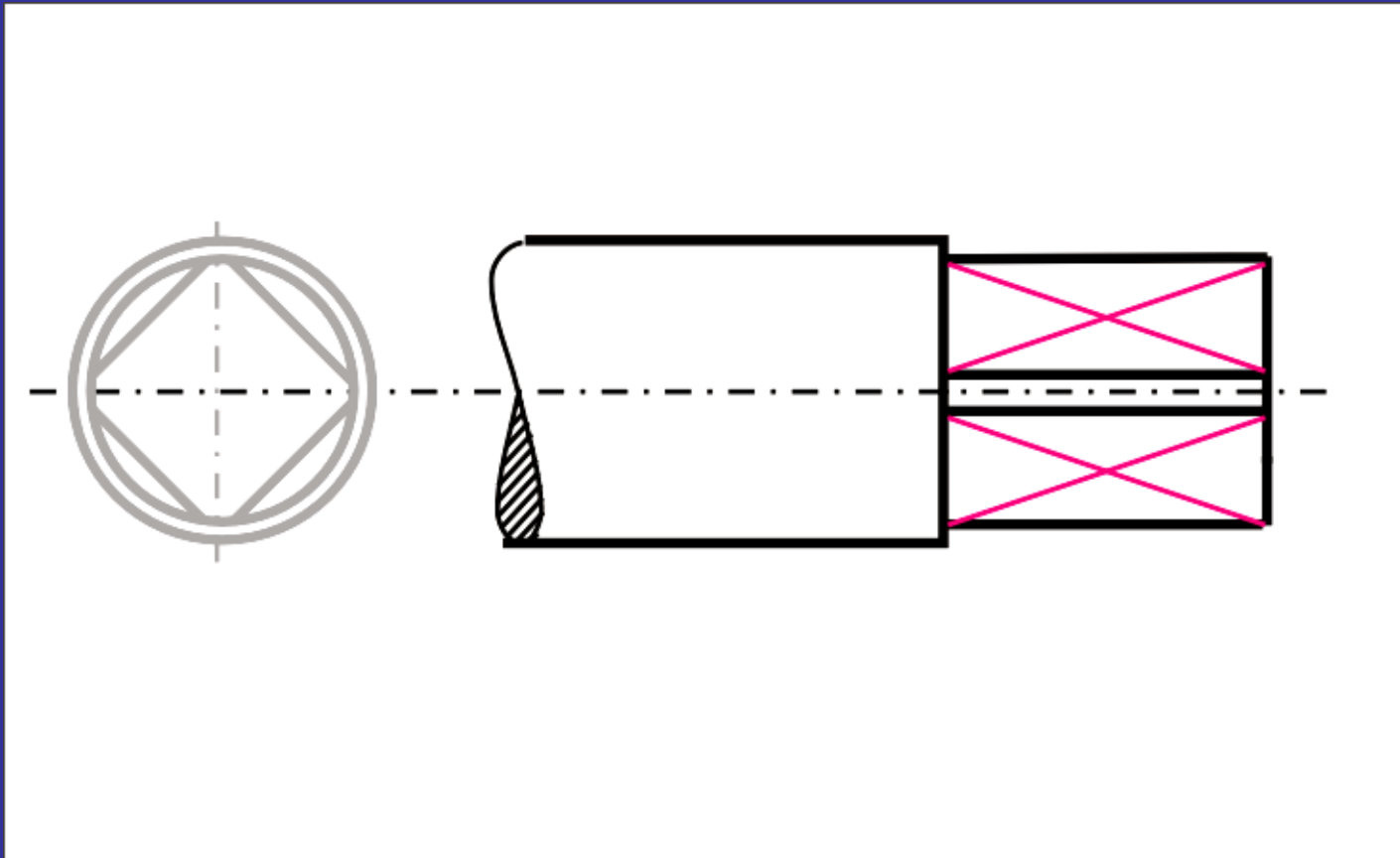



# Sík felület ábrázolása

(ha a vetületek nem elegendőek a sík jelleg érzékeltetésére)

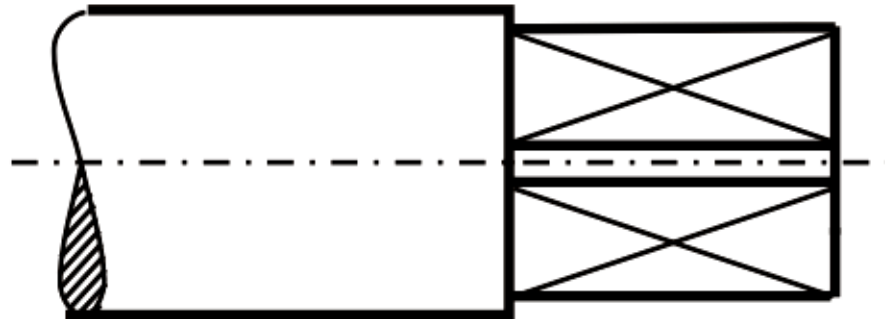

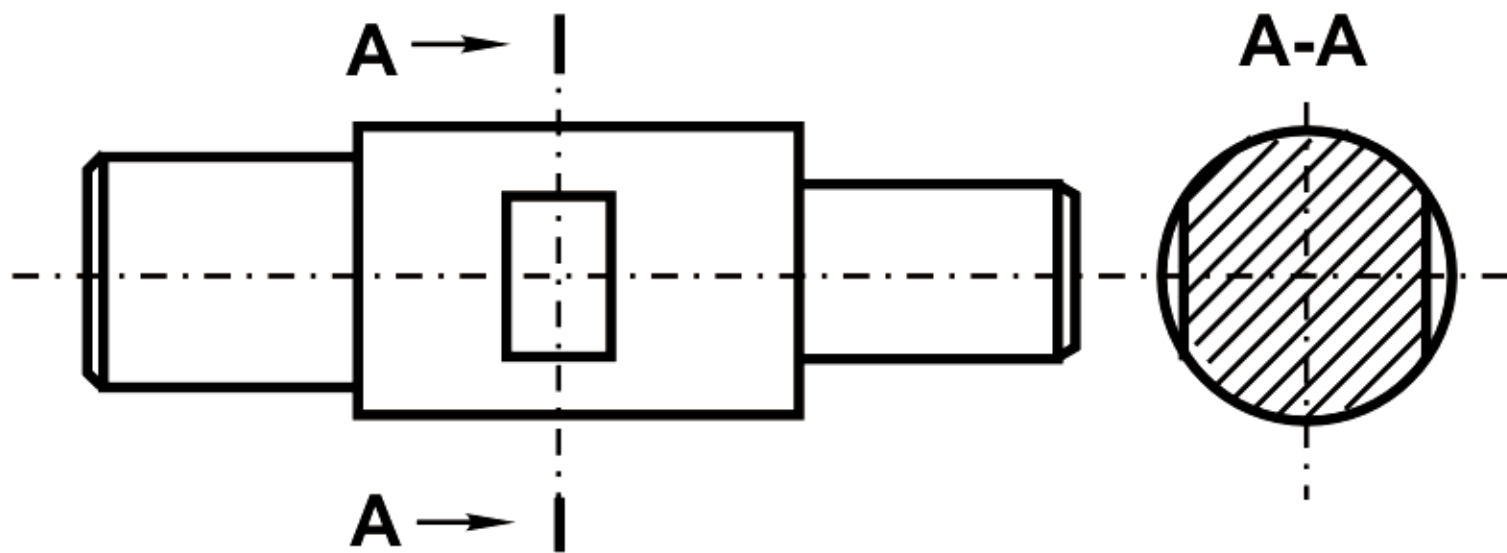

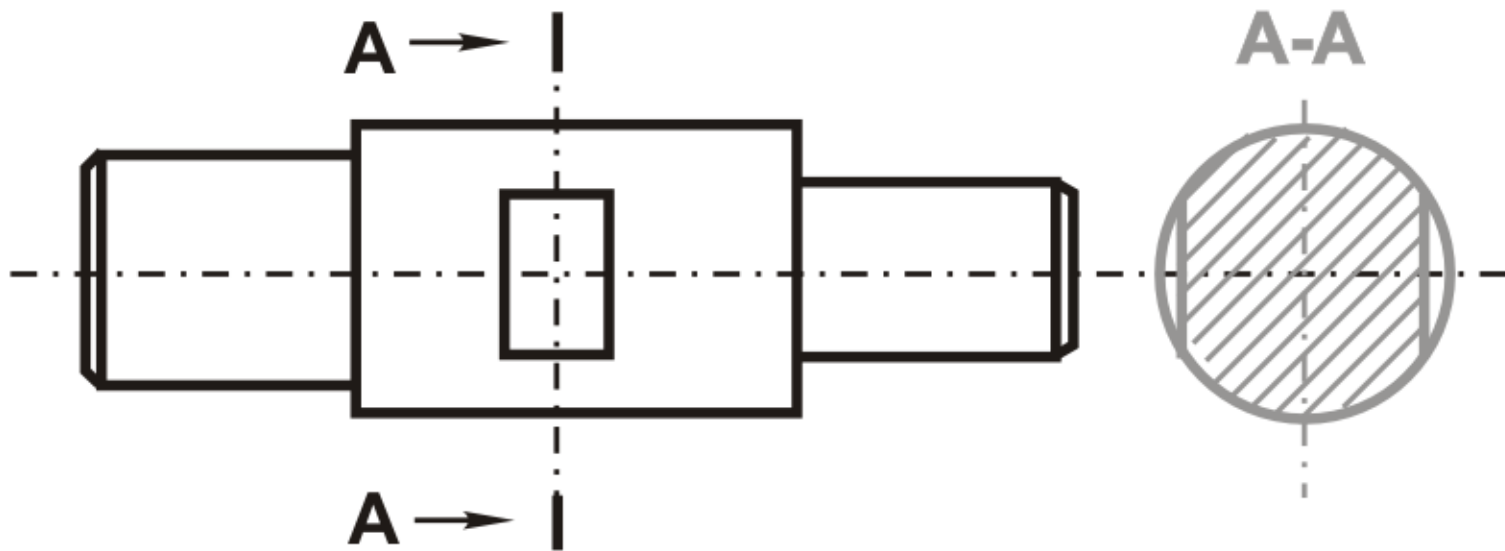

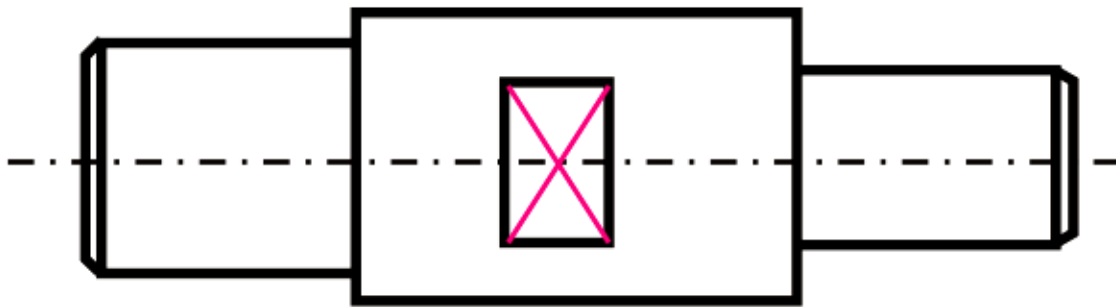

# A MÉRETMEGADÁS SZABÁLYAI

# A MÉRETMEGADÁS JELEI

# A méretmegadás alapsémája

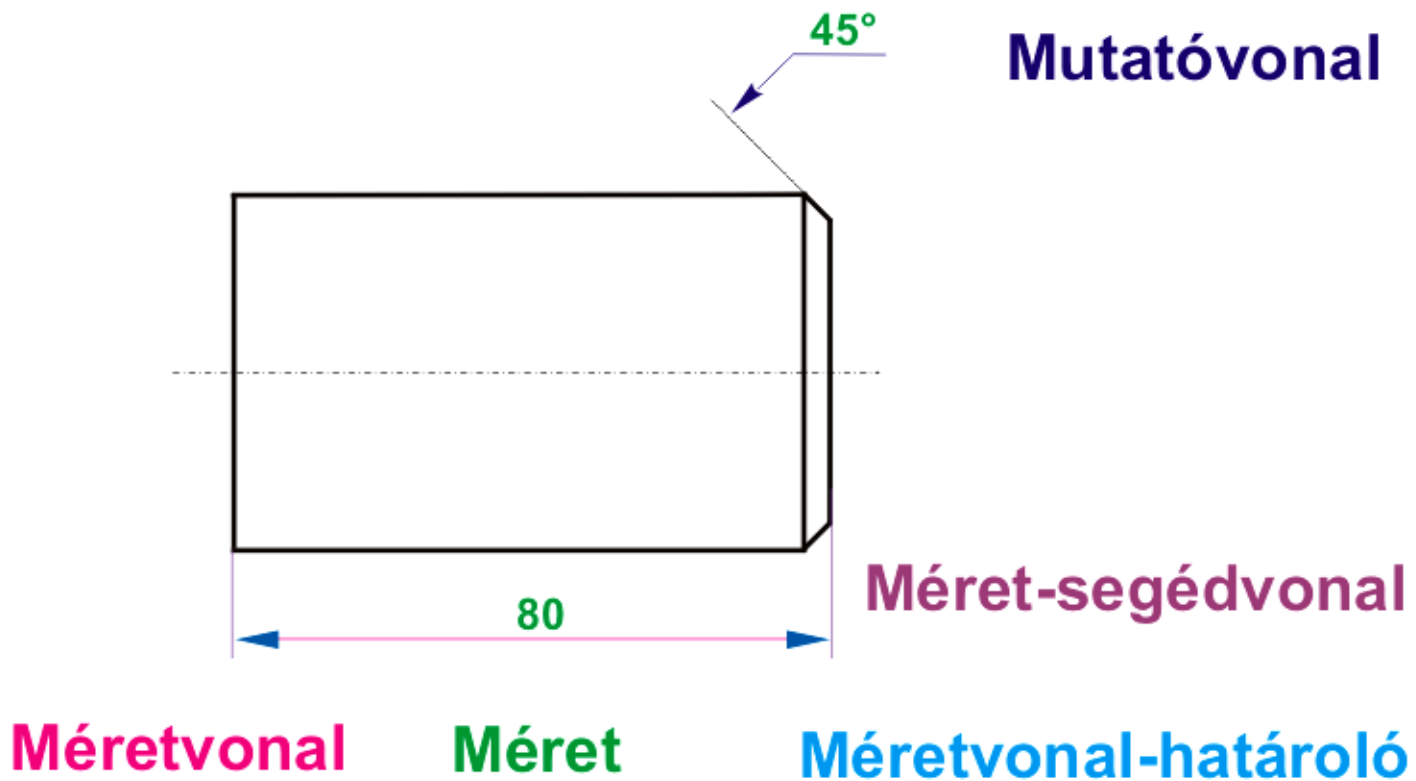

# A méretvonal

**Formája:** vékony vonal (0,35 mm)

**Célja:** a méretezett szakasz geometriai ábrázolása



# A méretvonalak párhuzamosak a méretezett szakasszal

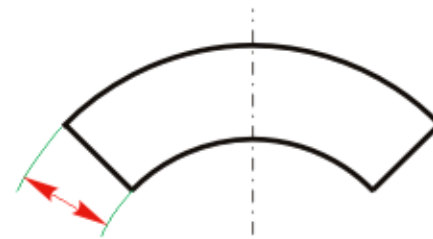
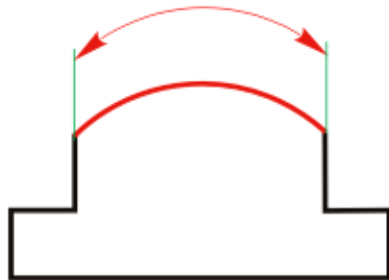
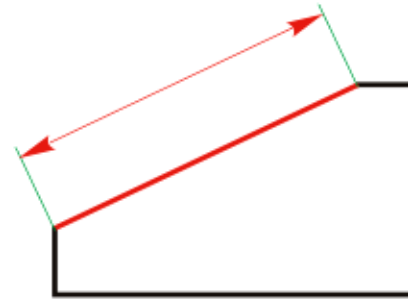
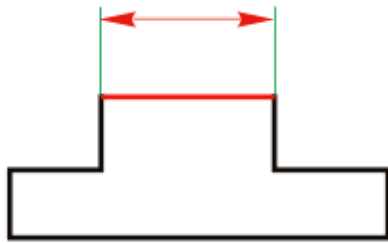

# A méretvonalak nem metszhetik egymást

TILOS!

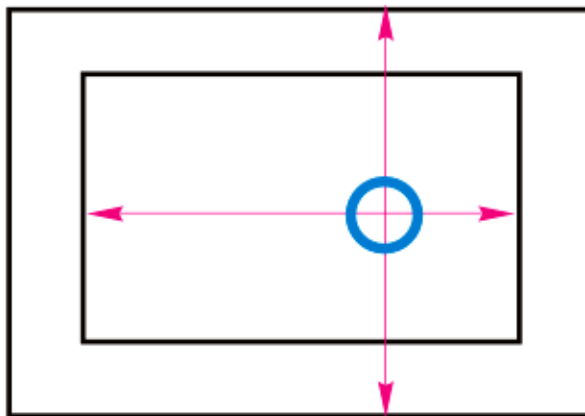

Kivétel

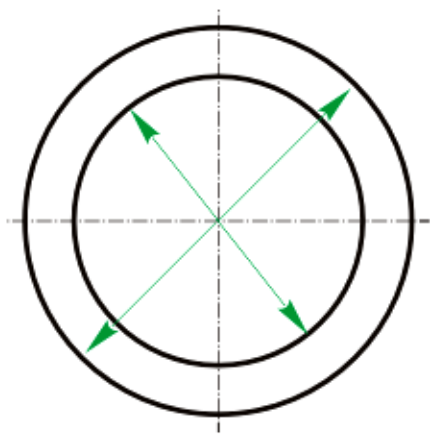

HELYES

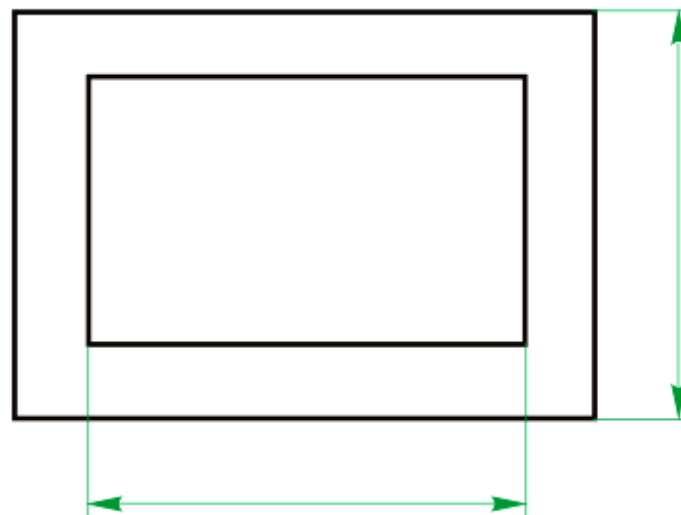

# A méretvonalak távolsága a többi vonaltól

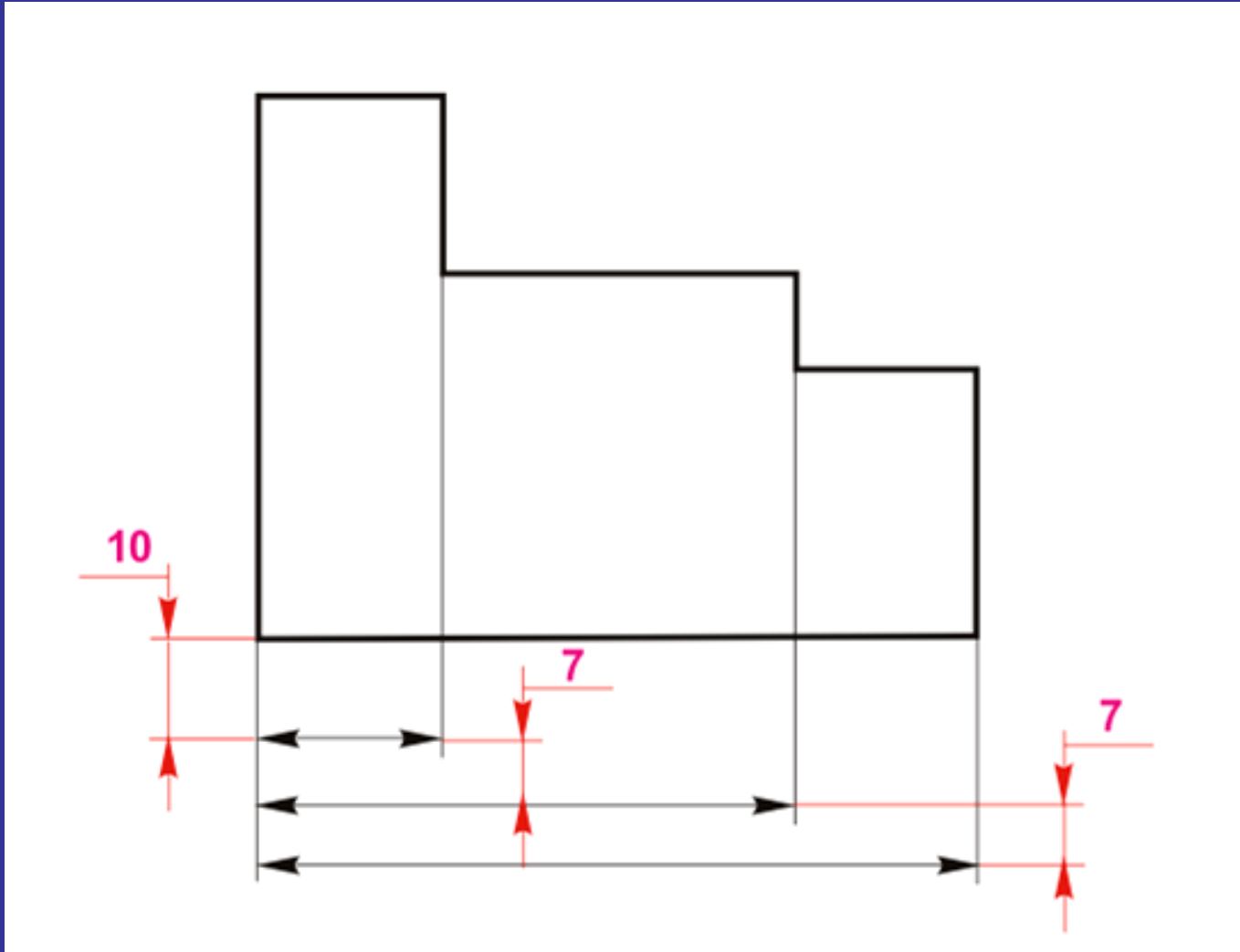

# A méretvonalak végpontjainak lehetséges helyzetei

**Kontúrvonal**



**Méret-segédvonal**

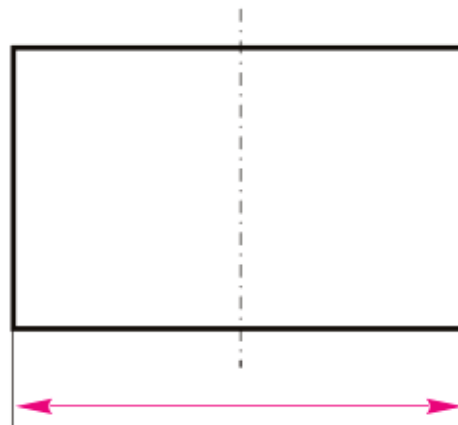

**Középvonal**

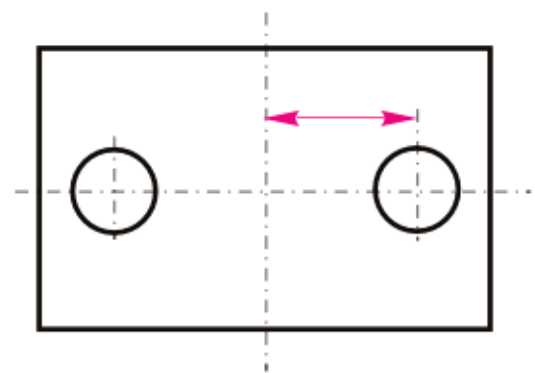

**Kombinációk**

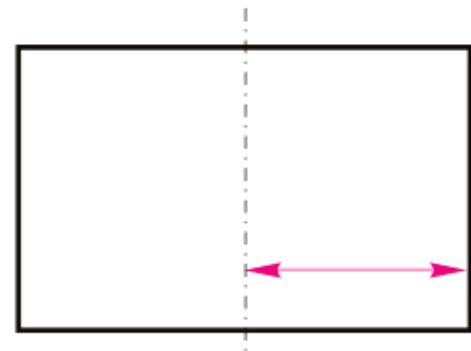
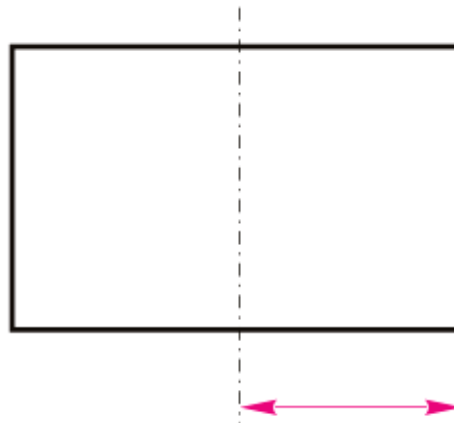
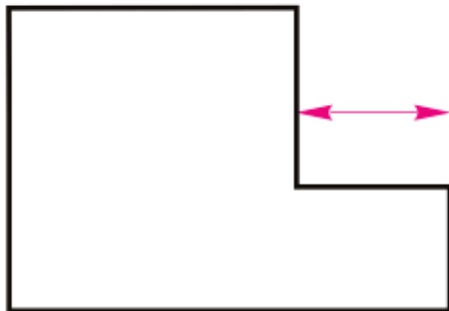

# Méretvonalaként nem használható vonalak

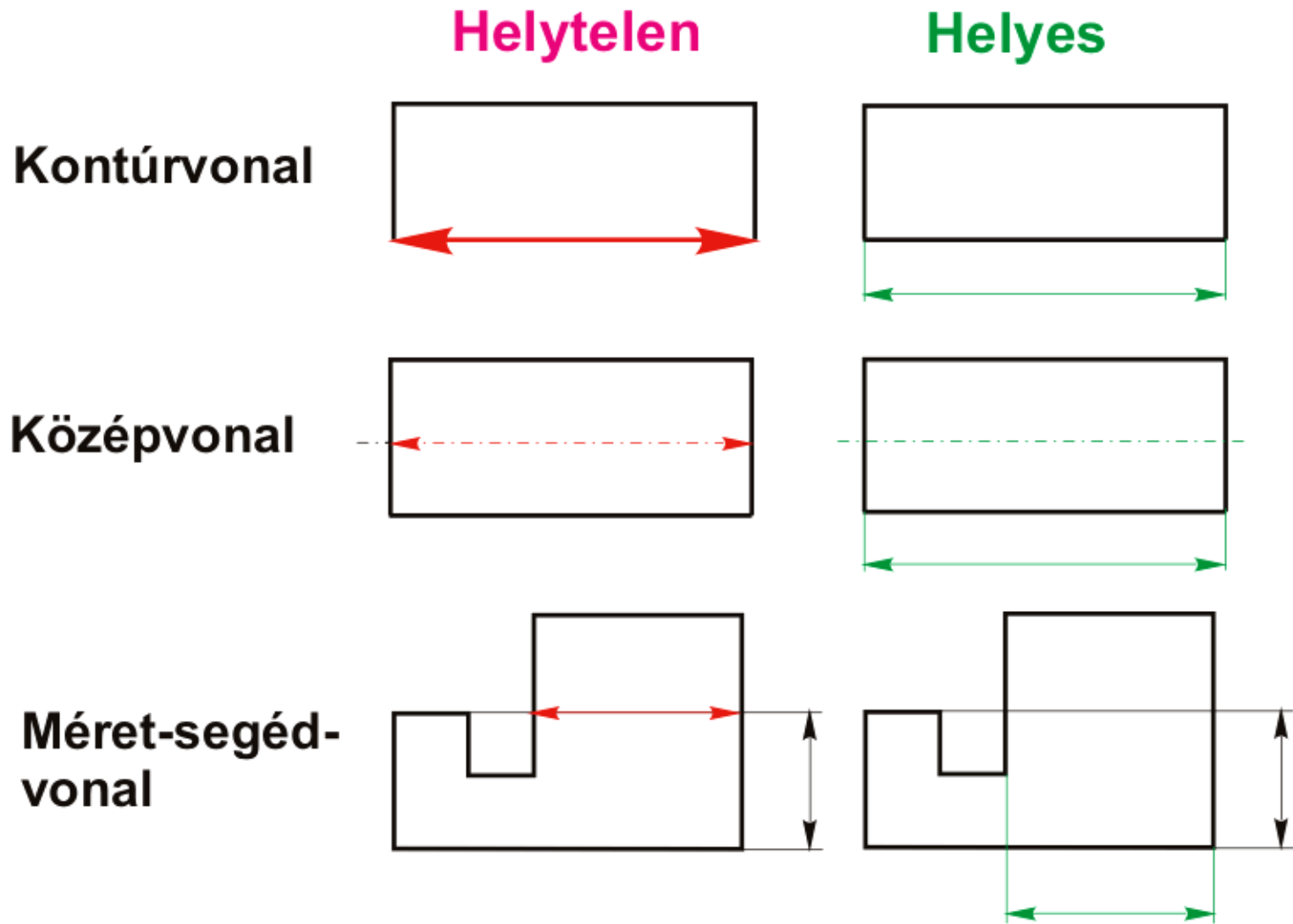

# Íves felültek méretvonalai

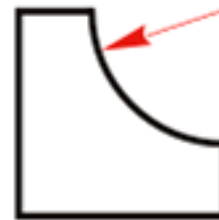
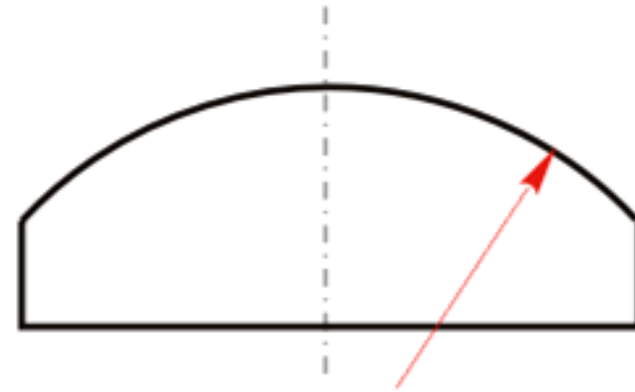
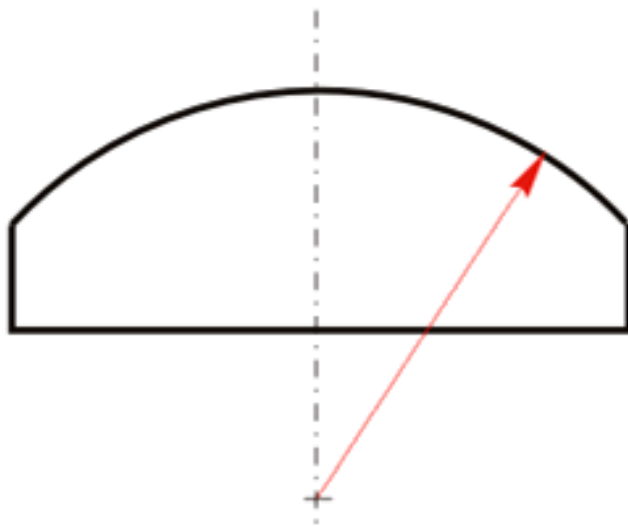

# A méret-segédvonal

**Formája:** vékony vonal

**Célja:** kivetített méretek jelzése

# Méret-segédvonal változatok

## Lekerekített felületek

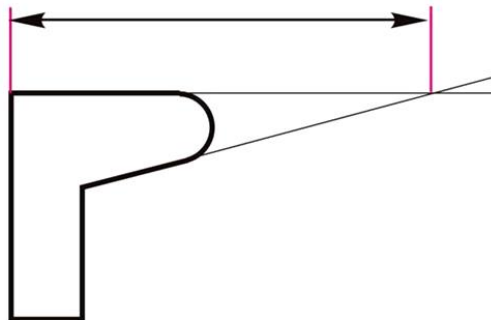

## Íves felületek

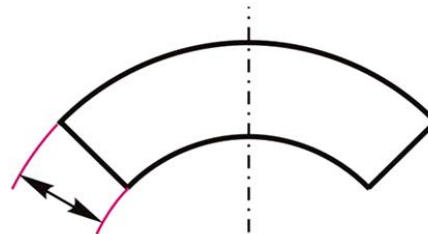

## Szöget bezáró felületek

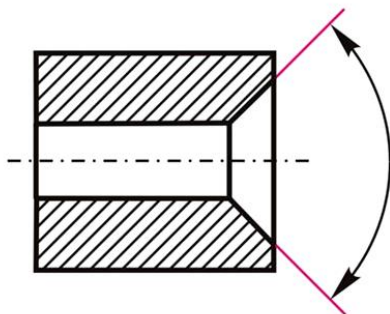

## Átlósan kiemelt méretvonalak

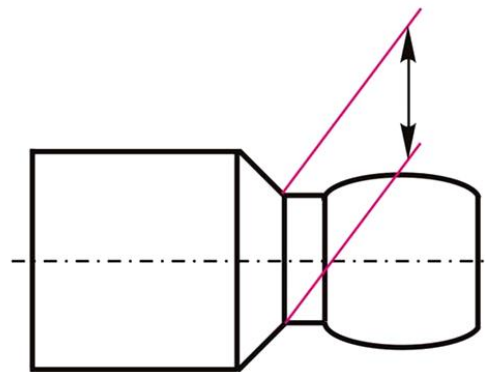



# A méretvonal-határoló

# Méretvonal-határolók változatai

**Kiindulási jel**

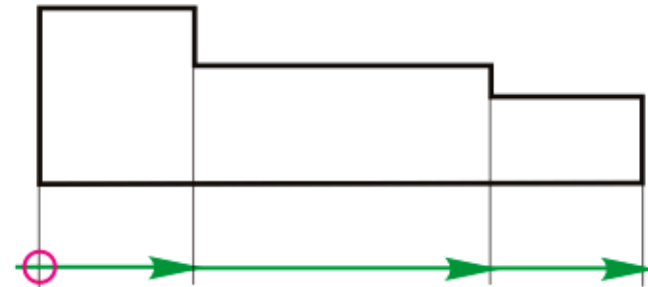

**Nyíl**

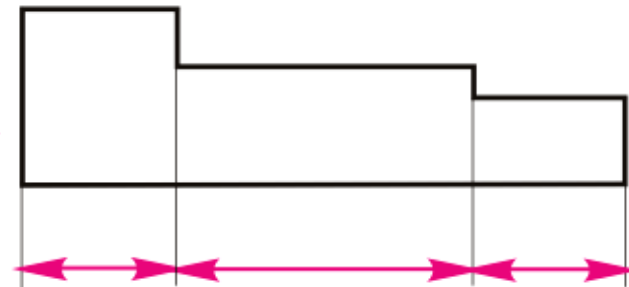

**Ferde vonás**



# A nyíl szokásos formája

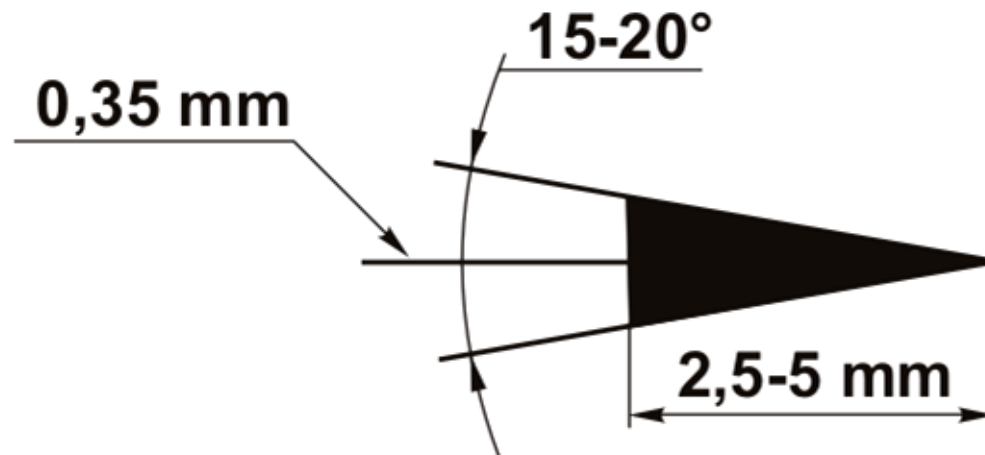

# A nyíl elhelyezési lehetőségei

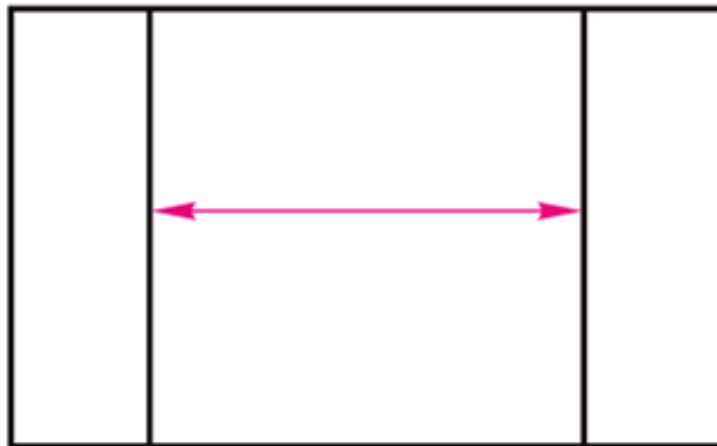
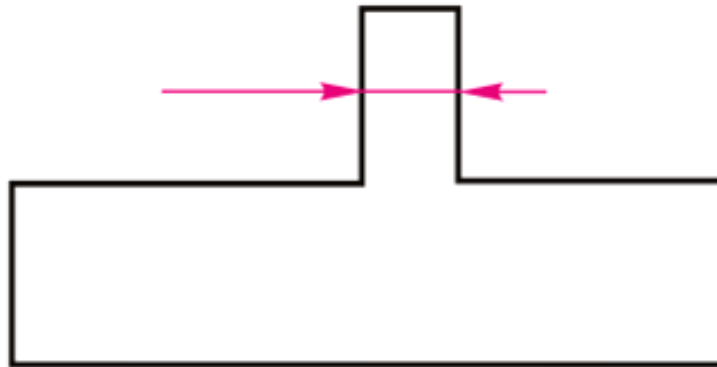

# A nyíllal fedésben lévő rajzi elemek ábrázolása

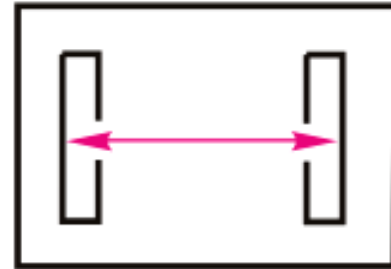
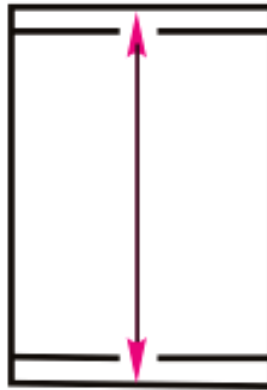
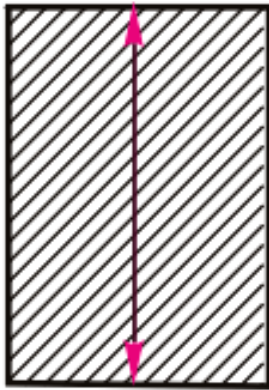

# A mutatóvonal

**Formája:** vékony vonal (0,35 mm)

**Célja:** a kiemelt szöveg (méret) helyzetének jelölése

# A mutatóvonal alakja

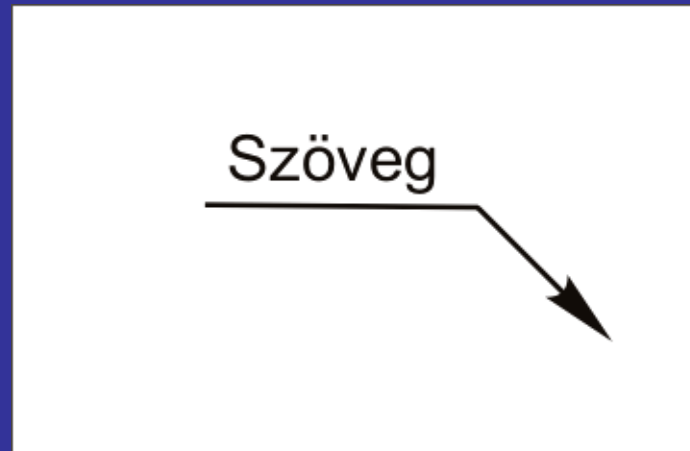

# A mutatóvonal elhelyezésének változatai

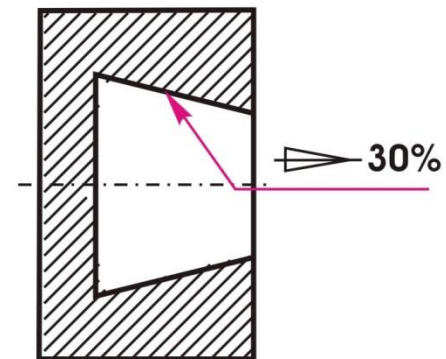
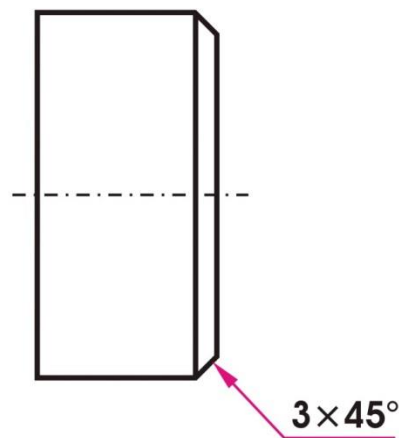
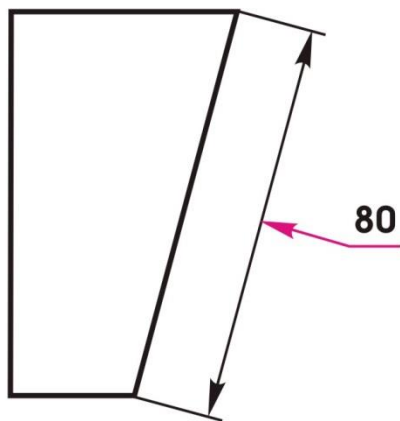



# A méret felirata

Betűnagyság: **3,5 mm**

Méreték mértékegysége: **mm**

Mértékegység **nem** írandó ki

A szöveg (méretszám) a méretvonal felett, középen,  
**balról jobbra, vagy alulról felfelé** legyen olvasható

# A szöveg elhelyezésének változatai I.

Helyes

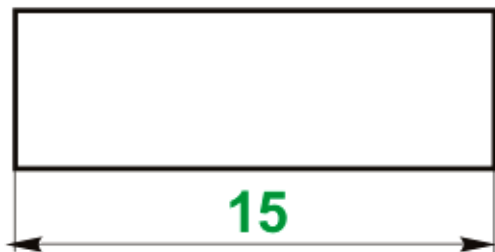

Tiltott!



# A szöveg elhelyezésének változatai II.

**Helyes**

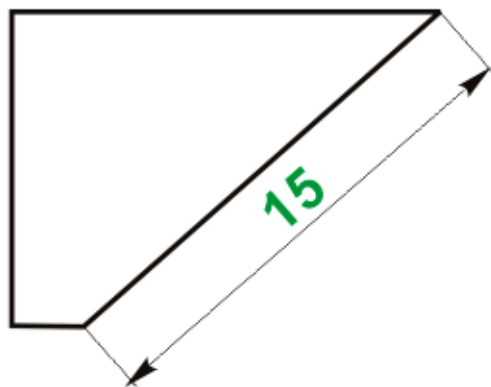

**Tiltott!**

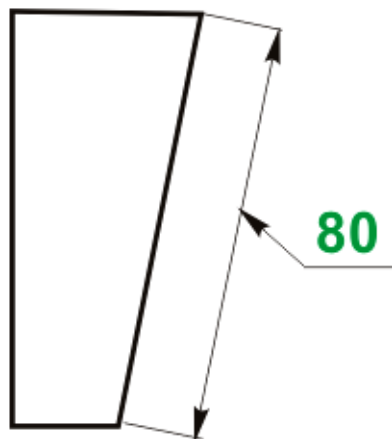
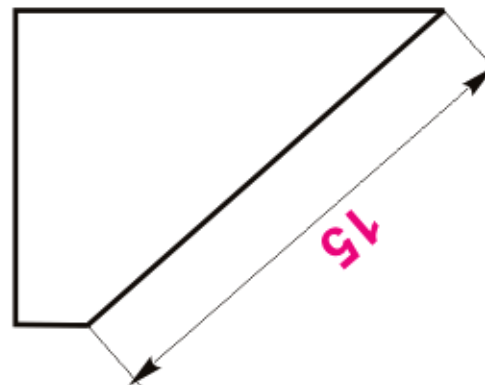

**Az alkatrész alakjára utaló jelek**

# Hengeres, lekerekített és négyzetes hasáb alakú alkatrészek

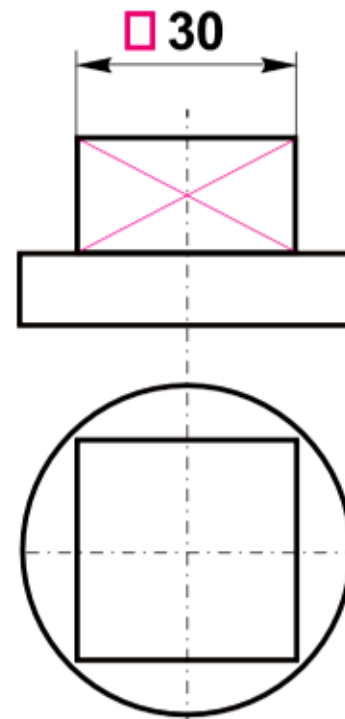
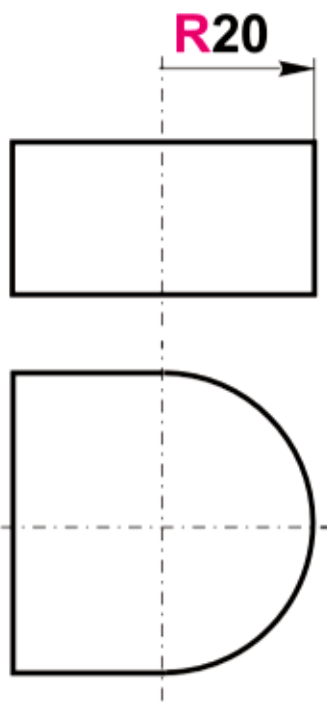
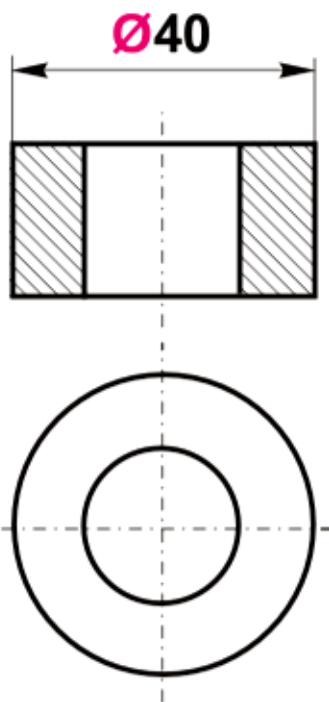

# Gömbfelületű és íves alkatrészek

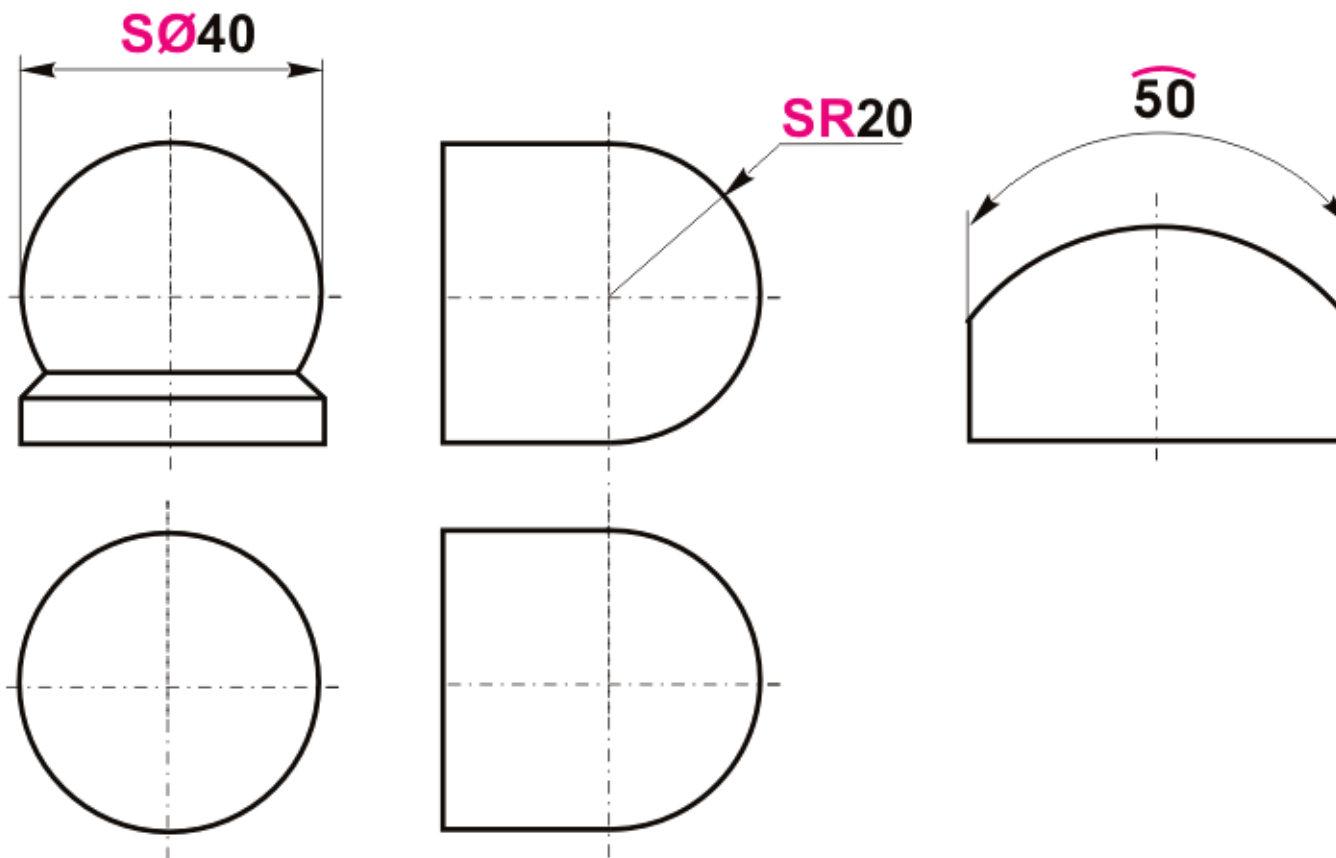

**Megengedhető egyszerűsítések**

## Csak az átmérő felének jelölése

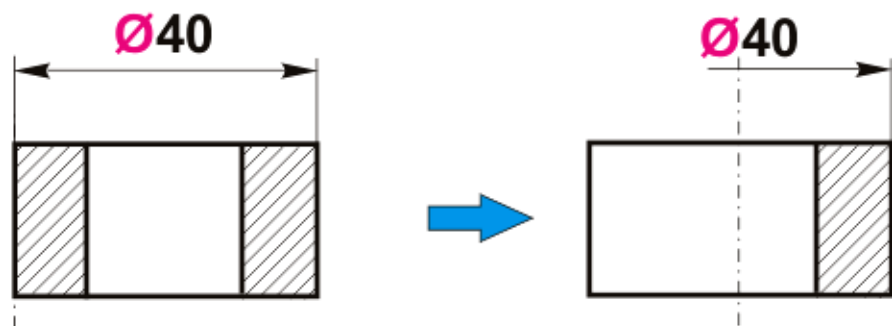

## A sugár számértékének elhagyása

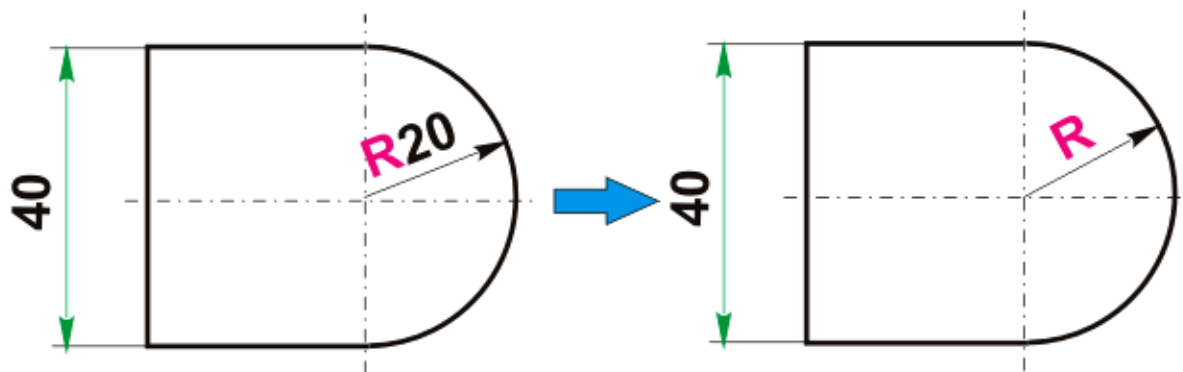



# Éltompítások összevont jelölése

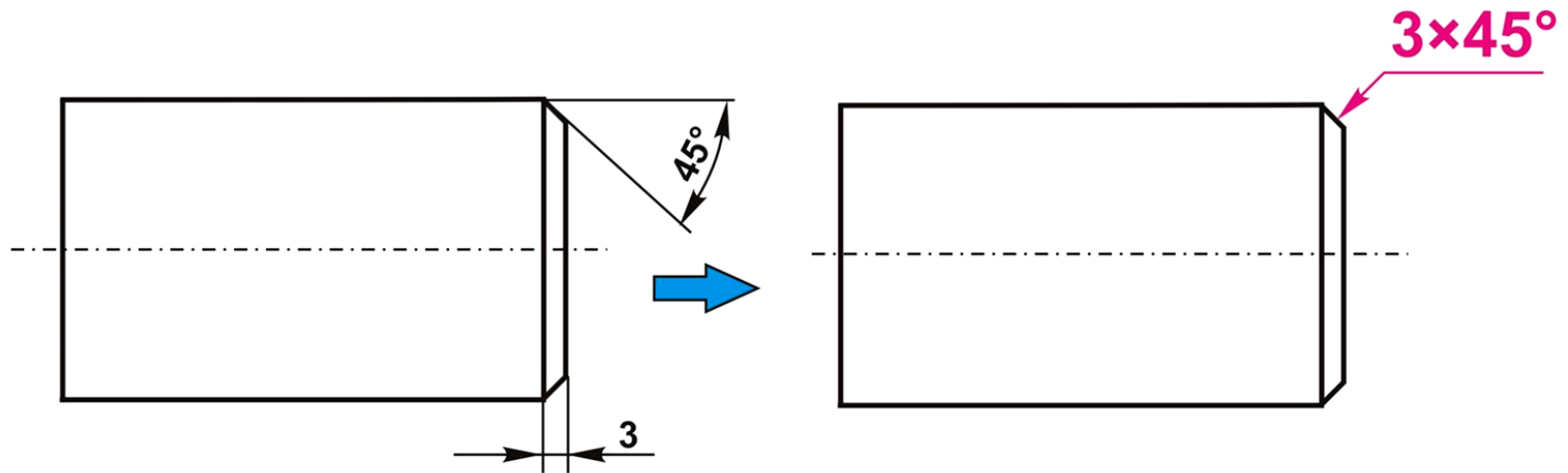

# MÉRETHÁLÓZATOK

# A mérethálózatok általános jellemzése

- **Fogalma:**
  - rajz méretmegadásainak összessége
- **Alapelvei:**
  - Minden méret egyszer megadandó
  - Egy méret csak egyszer adható meg
  - Zárt méretlánc alkalmazása tilos
  - A mérethálózat legyen áttekinthető

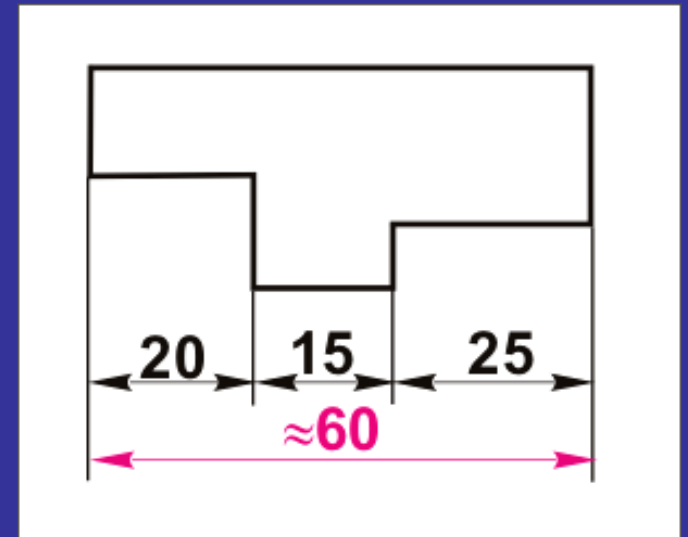

# A mérethálózat igazodjon a gyártás technológiájához

Helytelen

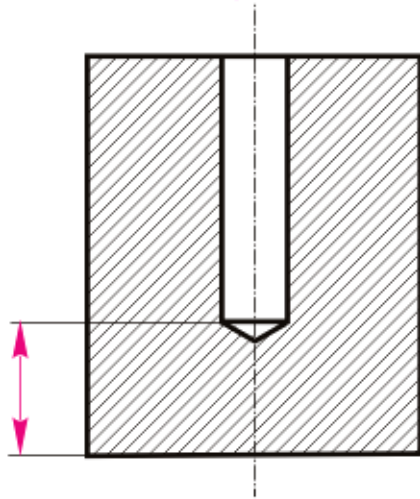

Helyes

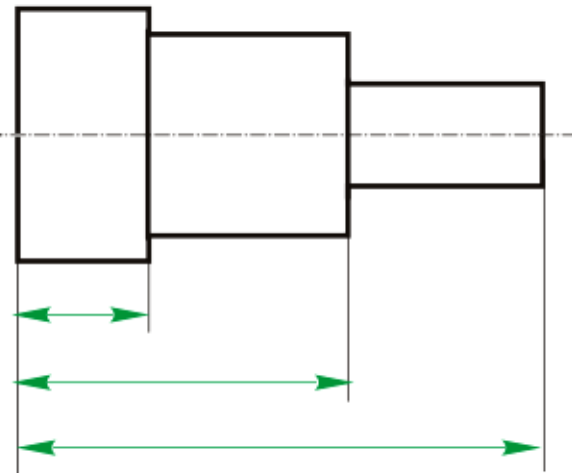
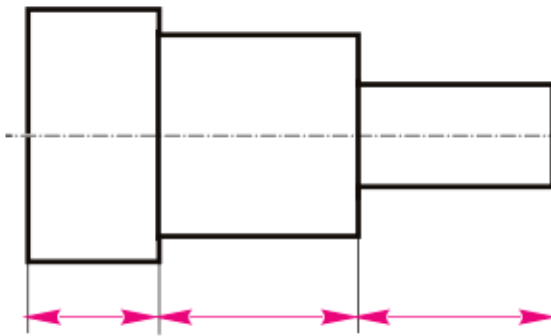
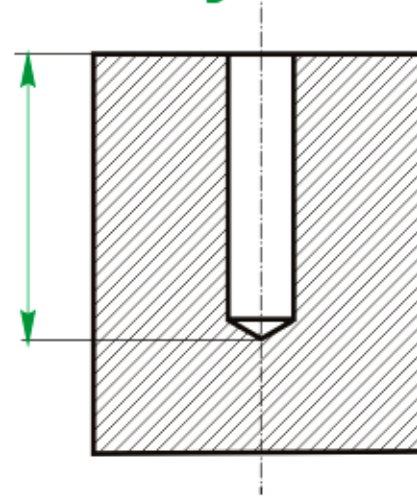

# A mérethálózat igazodjon az ellenőrző mérések menetéhez

**Helytelen**

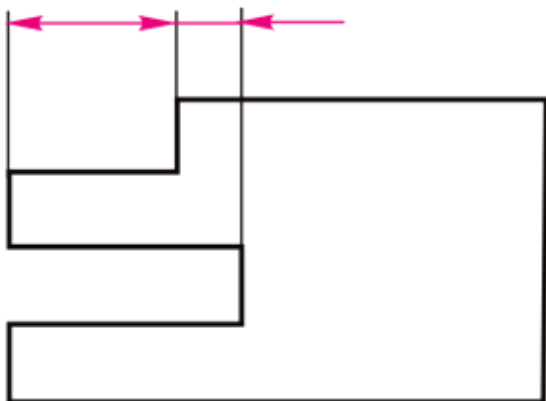

**Helyes**

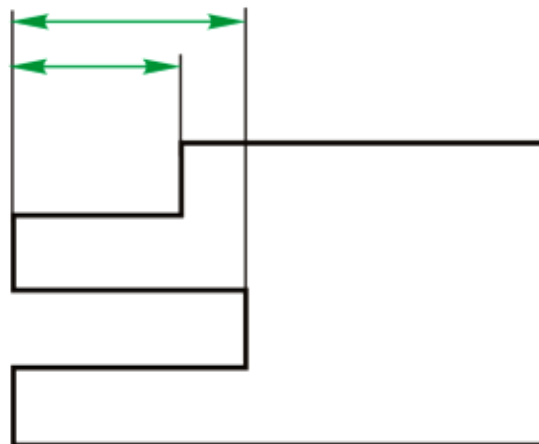

# A mérethálózatok fajtái

## Láncszerű mérethálózat

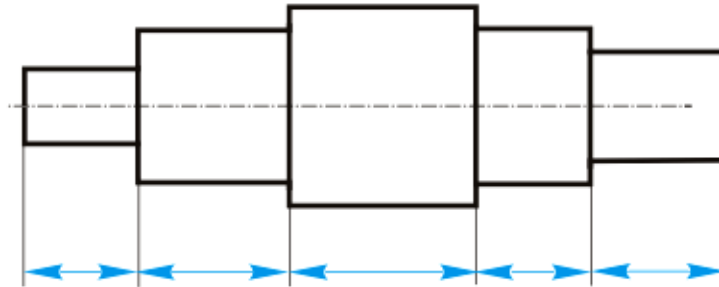

## Bázistól induló mérethálózat

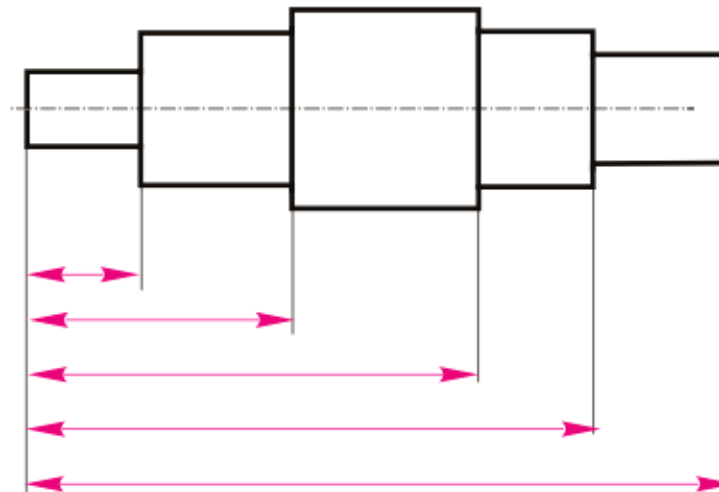

# Bázistól induló mérethálózatok

# A bázistól induló mérethálózat változatai

## Párhuzamos

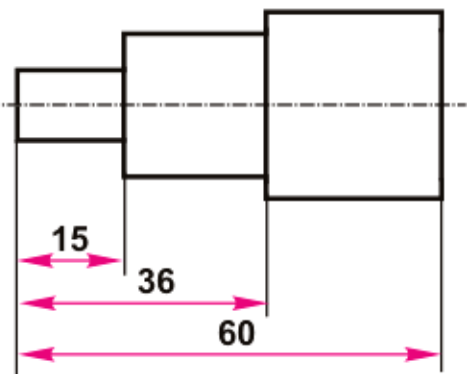

## Összevont

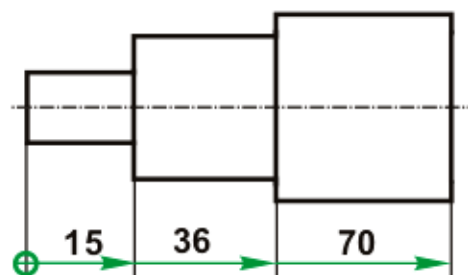

## Koordinátás

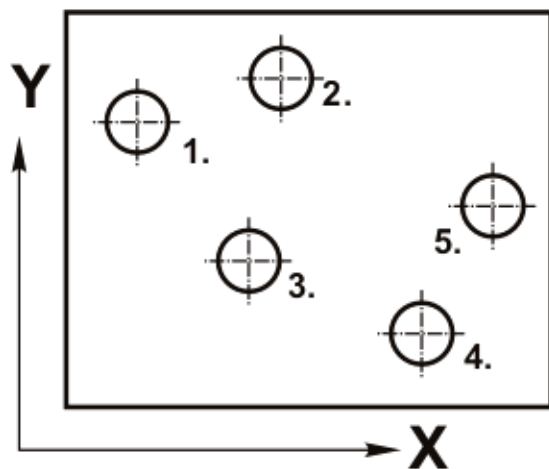

N°	X [mm]	Y [mm]
1.	10	40
2.	30	44
3.	23	20
4.	50	10
5.	60	30



# A bázis kiválasztásának szempontjai

# Bázis: az alkatrész működése miatt fontos felület

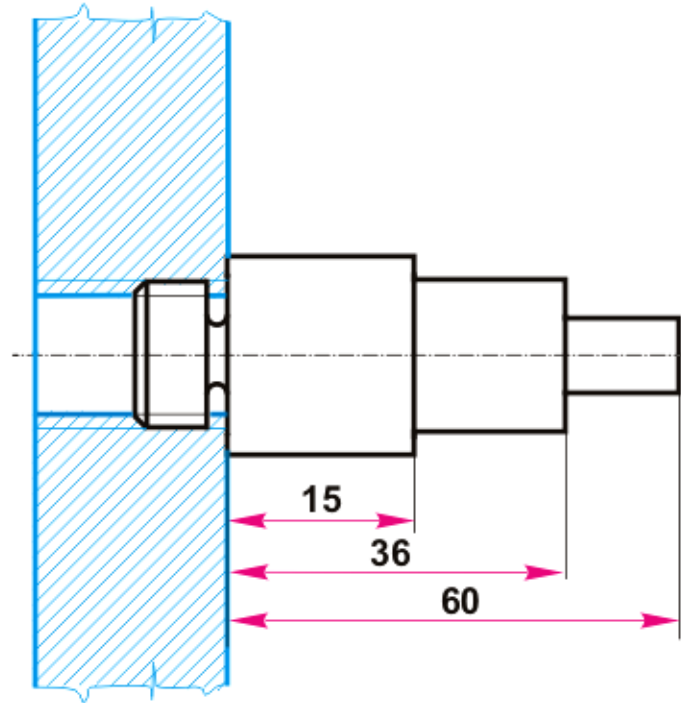

# Bázis: az alkatrész működése miatt fontos szimmetriatengely

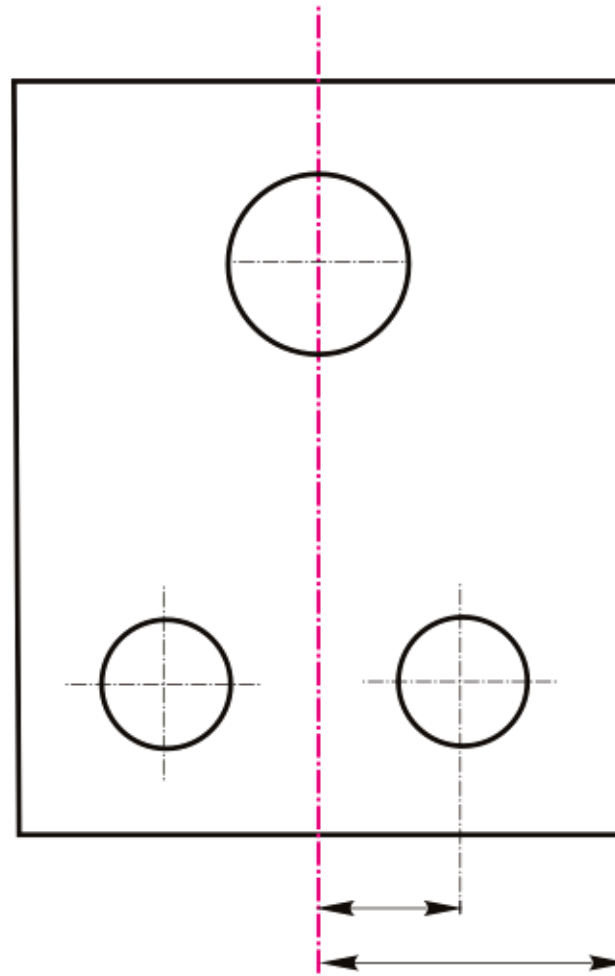

# Bázis: az alkatrész valamely fő méretének határoló vonala

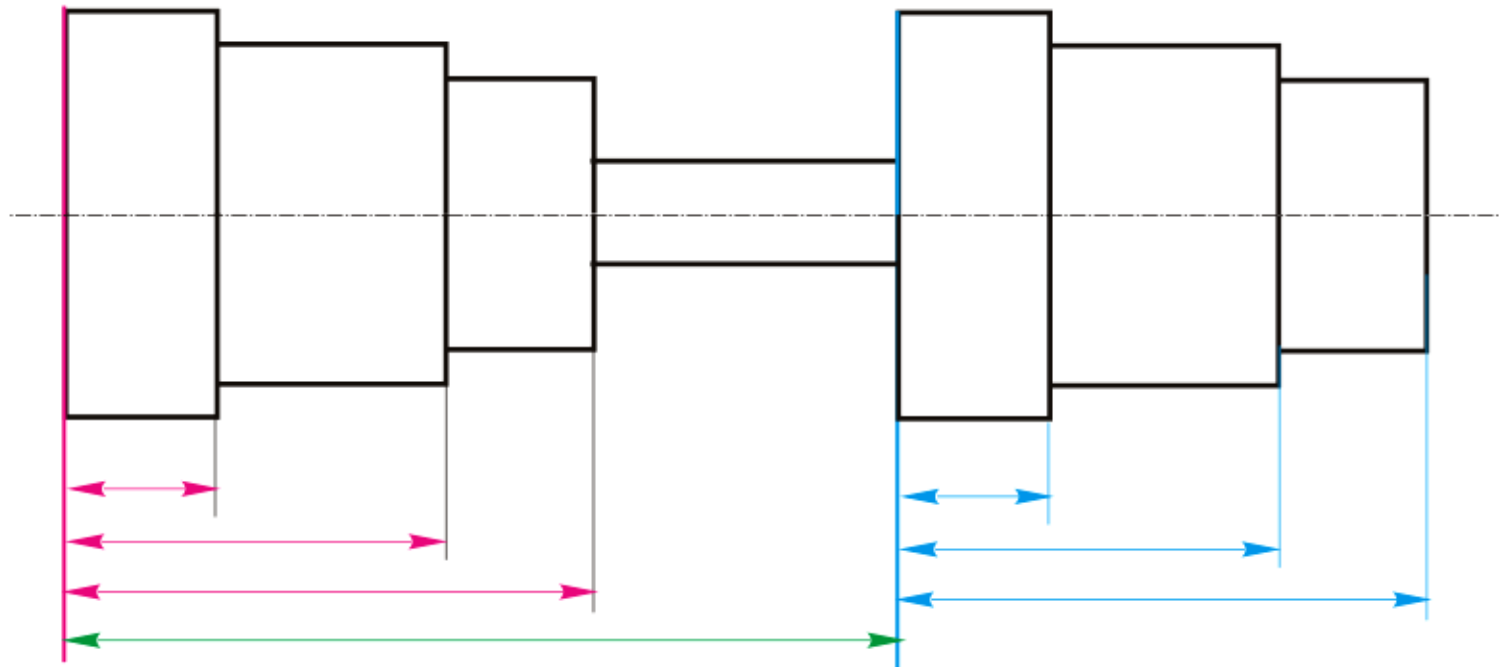

# **A mérethálózat elhelyezésének szempontjai**

# A méreteket a legjellemzőbb vetületen kell megadni

**Helytelen**

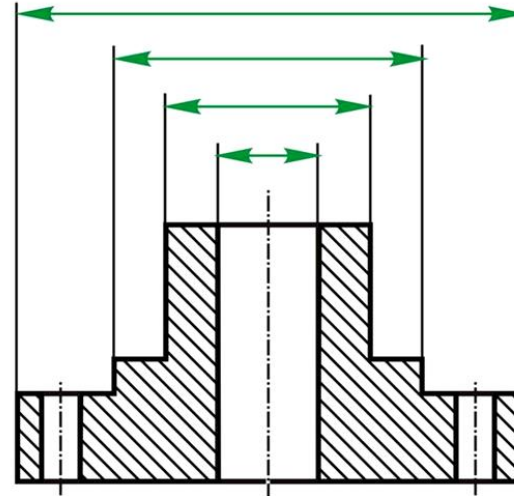
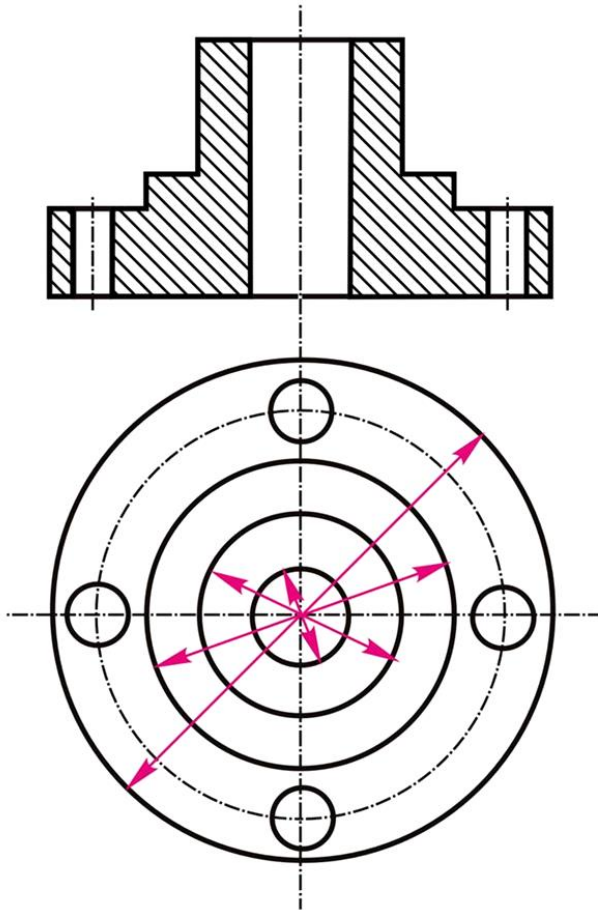

**Helyes**

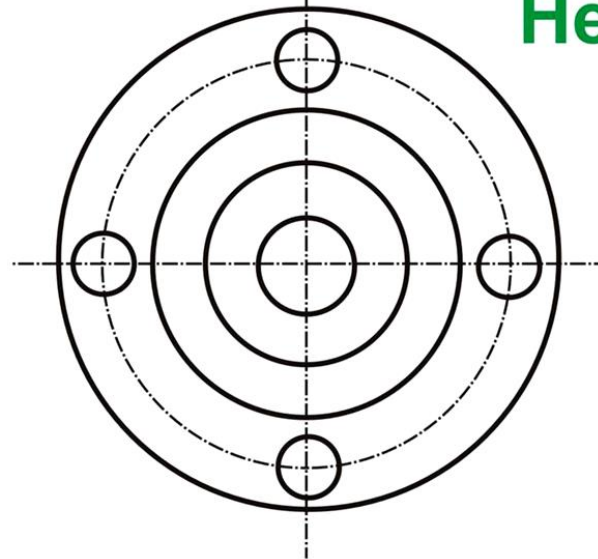

# Egy geometriai egységet alkotó méretcsoportot lehetőleg ugyanazon a vetületen adjuk meg

**Helytelen**

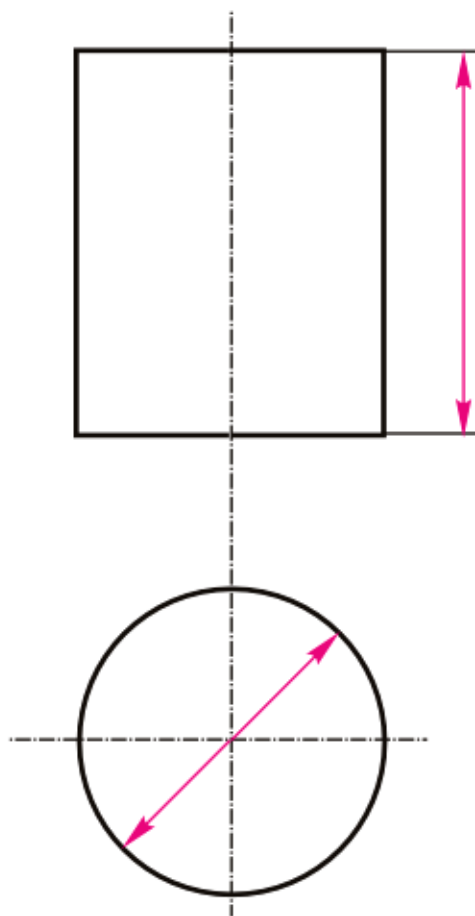

**Helyes**

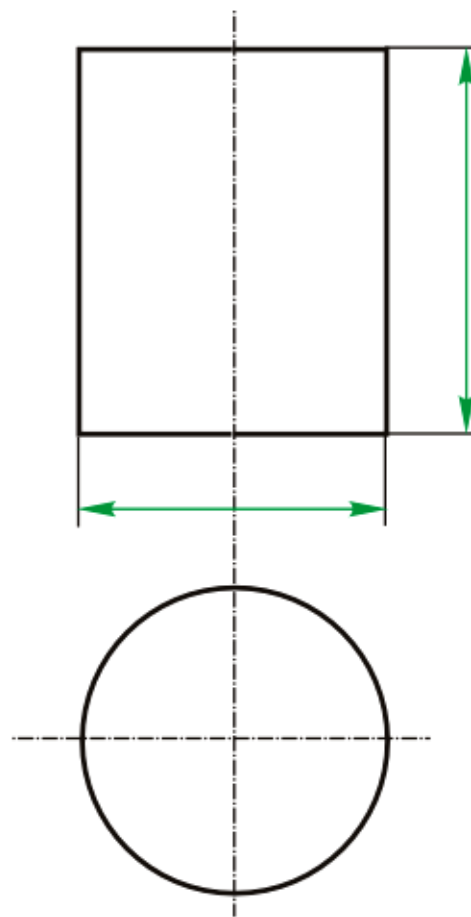

# Összeállítási rajzon a különböző alkatrészek mérethálózata lehetőleg alkosson elkülönülő csoportokat

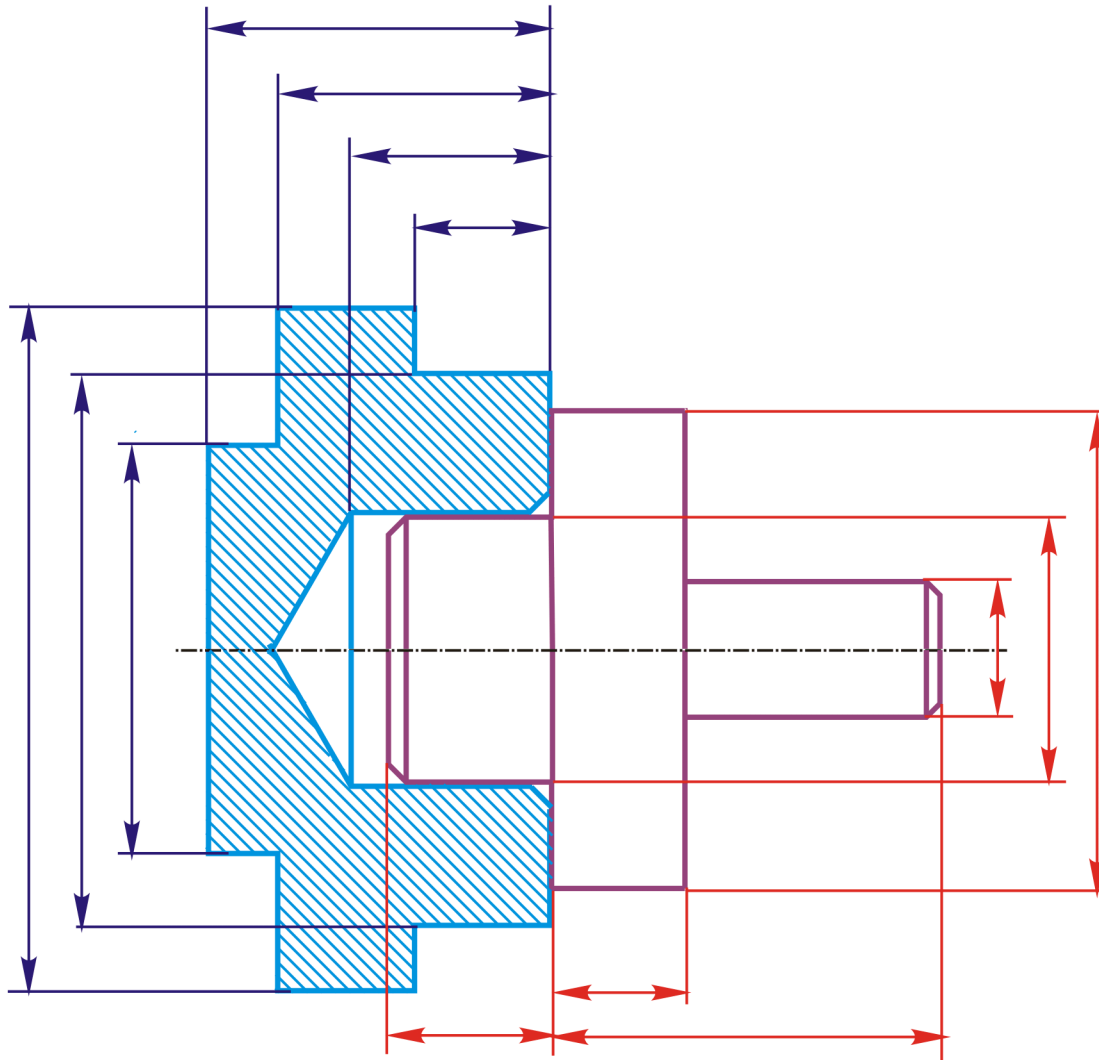



**KÖSZÖNÖM A FIGYELMET**